

IAEA SAFETY STANDARDS

for protecting people and the environment

SPSS STEP 12

Advisory Material

for the IAEA Regulations for the Safe Transport of Radioactive Material

(2018 Edition)

DRAFT SAFETY GUIDE

DS496

Revision of SSG-26

NOTE:

Contents, tables, equations, figures and index need to be revised for correct final edition

IAEA

International Atomic Energy Agency

SECTION I	1 INTRODUCTION	1
	BACKGROUND	1
	OBJECTIVE	4
	SCOPE 4	
	REFERENCES TO SECTION I	8
SECTION II	DEFINITIONS.....	10
	REFERENCES TO SECTION II	27
SECTION III	GENERAL PROVISIONS	29
	RADIATION PROTECTION	29
	EMERGENCY RESPONSE.....	32
	MANAGEMENT SYSTEM.....	33
	COMPLIANCE ASSURANCE.....	34
	NON-COMPLIANCE	35
	SPECIAL ARRANGEMENT.....	36
	TRAINING	37
	REFERENCES TO SECTION III	38
SECTION IV	ACTIVITY LIMITS AND CLASSIFICATION	42
	GENERAL PROVISIONS	42
	BASIC RADIONUCLIDE VALUES.....	42
	DETERMINATION OF BASIC RADIONUCLIDE VALUES	44
	CLASSIFICATION OF MATERIAL	46
	CLASSIFICATION OF PACKAGES.....	59
	REFERENCES TO SECTION IV	63
SECTION V	REQUIREMENTS AND CONTROLS FOR TRANSPORT.....	66
	REQUIREMENTS BEFORE THE FIRST SHIPMENT.....	66
	REQUIREMENTS BEFORE EACH SHIPMENT	67
	TRANSPORT OF OTHER GOODS.....	70
	OTHER DANGEROUS PROPERTIES OF CONTENTS.....	70
	REQUIREMENTS AND CONTROLS FOR CONTAMINATION AND FOR LEAKING PACKAGES	72
	REQUIREMENTS AND CONTROLS FOR TRANSPORT OF EXCEPTED PACKAGES	76
	REQUIREMENTS AND CONTROLS FOR TRANSPORT OF LSA MATERIAL AND SCO _s IN INDUSTRIAL PACKAGES OR UNPACKAGED.....	77
	DETERMINATION OF TRANSPORT INDEX (TI).....	80
	DETERMINATION OF CRITICALITY SAFETY INDEX FOR CONSIGNMENTS, FREIGHT CONTAINERS AND OVERPACKS ..	81
	LIMITS ON TRANSPORT INDEX, CRITICALITY SAFETY INDEX AND DOSE RATES FOR PACKAGES AND OVERPACKS.....	81
	CATEGORIES.....	82
	MARKING, LABELLING AND PLACARDING	84

CONSIGNOR'S RESPONSIBILITIES	89
TRANSPORT AND STORAGE IN TRANSIT	91
CUSTOMS OPERATIONS.....	103
UNDELIVERABLE CONSIGNMENTS.....	104
RETENTION AND AVAILABILITY OF TRANSPORT DOCUMENTS BY CARRIERS.....	104
REFERENCES TO SECTION V	104
 SECTION VI REQUIREMENTS FOR RADIOACTIVE MATERIAL AND FOR PACKAGINGS AND PACKAGES.....	 109
REQUIREMENTS FOR RADIOACTIVE MATERIAL.....	109
REQUIREMENTS FOR MATERIAL EXCEPTED FROM FISSILE CLASSIFICATION	112
GENERAL REQUIREMENTS FOR ALL PACKAGINGS AND PACKAGES	114
ADDITIONAL REQUIREMENTS FOR PACKAGES TRANSPORTED BY AIR	117
REQUIREMENTS FOR INDUSTRIAL PACKAGES.....	118
REQUIREMENTS FOR PACKAGES CONTAINING URANIUM HEXAFLUORIDE	122
REQUIREMENTS FOR TYPE A PACKAGES.....	125
REQUIREMENTS FOR TYPE B(U) PACKAGES	130
REQUIREMENTS FOR TYPE B(M) PACKAGES.....	142
REQUIREMENTS FOR TYPE C PACKAGES	143
REQUIREMENTS FOR PACKAGES CONTAINING FISSILE MATERIAL. 144	
DETERMINATION OF CRITICALITY SAFETY INDEX (CSI) FOR PACKAGES	155
REFERENCES TO SECTION VI.....	156
 SECTION VII TEST PROCEDURES.....	 163
DEMONSTRATION OF COMPLIANCE.....	163
TESTS FOR SPECIAL FORM RADIOACTIVE MATERIAL	168
TESTS FOR LOW DISPERSIBLE RADIOACTIVE MATERIAL (LDRM)....	169
TESTS FOR PACKAGES.....	170
REFERENCES TO SECTION VII.....	193
 SECTION VIII APPROVAL AND ADMINISTRATIVE REQUIREMENTS..	 198
GENERAL.....	198
APPROVAL OF SPECIAL FORM RADIOACTIVE MATERIAL AND LOW DISPERSIBLE RADIOACTIVE MATERIAL (LDRM)	200
APPROVAL OF PACKAGE DESIGNS	200
TRANSITIONAL ARRANGEMENTS	202
APPROVAL OF SHIPMENTS	207
COMPETENT AUTHORITY APPROVAL CERTIFICATES	208
CONTENTS OF APPROVAL CERTIFICATES.....	209
REFERENCES TO SECTION VIII	215

APPENDIX I	THE Q SYSTEM FOR THE CALCULATION AND APPLICATION OF A_1 AND A_2 VALUES	217
APPENDIX II	HALF-LIFE AND SPECIFIC ACTIVITY OF RADIONUCLIDES, DOSE AND DOSE RATE COEFFICIENTS OF RADIONUCLIDES AND SPECIFIC ACTIVITY	259
APPENDIX III	EXAMPLE CALCULATIONS FOR ESTABLISHING MINIMUM SEGREGATION DISTANCE REQUIREMENTS	290
APPENDIX IV	PACKAGE STOWAGE AND RETENTION DURING TRANSPORT	299
APPENDIX V	GUIDELINES FOR THE SAFE DESIGN OF SHIPPING PACKAGES AGAINST BRITTLE FRACTURE	309
APPENDIX VI	CRITICALITY SAFETY ASSESSMENTS	324
APPENDIX VII	GUIDANCE FOR CALCULATION OF ACTIVITY INTAKE FOR TRANSPORT OF SCO-III.....	345
APPENDIX VIII	TRANSPORT UNDER SPECIFIC SITUATIONS.....	350
CONTRIBUTORS TO DRAFTING AND REVIEW		353
INDEX	FEHLER! TEXTMARKE NICHT DEFINIERT.	

Section I

INTRODUCTION

BACKGROUND

101.1. Radiation and radioactive substances are natural and permanent features of the environment, and thus the risks associated with radiation exposure can only be restricted, not eliminated entirely. Additionally, the use of human-made radiation is widespread. Sources of radiation are essential to modern health care. The worldwide use of nuclear energy and applications of its by-products (i.e. radiation and radioactive substances) continue to increase.

101.2. It has been recognized that exposure to high levels of radiation can cause damage to the tissues of the human body and that exposure to radiation has the potential for the induction of latent malignancies. It is therefore essential that activities involving radiation exposure, such as the transport of radioactive material, be subject to certain standards of safety in order to protect those individuals exposed to radiation. The IAEA radiation safety standards provide a desirable international consensus for this purpose.

101.3. The acceptance by society of risks associated with radiation is conditional on the benefits to be gained from the use of applications involving radiation. The Regulations for the Safe Transport of Radioactive Material (Transport Regulations¹) draw upon information derived from extensive research and development work by scientific and engineering organizations, at national and international levels, on the health effects of radiation and on techniques for the safe design of transport packages and from experience with transport operations. The Transport Regulations make use of purely scientific considerations, but also make value judgments about the relative importance of risks of different kinds and about the balancing of risks and benefits.

101.4. It is certain that some radiation exposures will result from routine conditions of transport and that their magnitudes will be predictable. Also, exposure scenarios can be envisaged for which there is a potential for exposure, but no certainty that an exposure will, in fact, occur. Such unexpected but feasible exposures are termed 'potential exposures'. Potential exposures can become actual exposures if the unexpected situation does occur. Optimization of radiation protection requires that both normal and potential exposures be taken into account. If the occurrence of such situations can be foreseen, the probability of occurrence and the resulting radiation exposure can be estimated. In the case of normal exposures, optimization requires that the expected magnitude of individual doses and the number of people exposed are taken into account; in addition, in the case of potential exposures, the likelihood of occurrence of accidents or events or sequences of events is also taken into account.

101.5. The means specified in the Transport Regulations for controlling normal exposures is the restriction of the doses received. The primary means for controlling potential exposures is by design of transport packages and operating procedures to meet requirements for dose rates, potential external contamination, activity release and prevention of criticality. Such means are also intended to restrict the probability of occurrence of events that could lead to unplanned

¹ Throughout this publication, reference to 'Transport Regulations' always refers to the latest edition unless otherwise stated

exposures and to restrict the magnitudes of the exposures that could result if such events were to occur.

101.6. The transport of radioactive material has established itself as necessary in national and international programmes for the use of radioactive material in medicine, agriculture, industry, research and generation of nuclear power. Transport of radioactive material is, thus, generally agreed as amply justified.

101.7. For individual members of the public, the dose limits set forth in IAEA Safety Standards Series No. GSR Part 3, Radiation Protection and Safety of Radiation Sources: International Basic Safety Standards [1] apply to the representative person of the population and to the total individual dose from all sources of exposure, excluding natural background radiation and medical exposure of individuals. In practice, to take into account other sources of exposure, requirements in the Transport Regulations are formulated on the basis of conservative assumptions in the definition of the exposure conditions of the representative person, to provide reasonable assurance that actual doses from transport of such packages will not exceed certain fractions of the dose limits.

101.8. The responsibility for the development and optimization of operational procedures and for compliance with the Transport Regulations rests primarily with the operator.

101.9. The provision of information and training is an integral part of any system of radiation protection. The level of instruction provided is required to be commensurate with the nature and type of work undertaken.

101.10. For training provisions, see paras 311–315.

101.11. The development and application of the management system, as required by the Transport Regulations, should be carried out in a timely manner, before transport operations commence. Where appropriate, the competent authority will verify that such a management system is implemented, in compliance with the Transport Regulations.

103.1. When making national or international shipments, it is necessary to consult the regulations for the particular mode of transport to be used for the countries where the shipment will be made. While most of the major modal requirements are in agreement with the Transport Regulations, there can be differences with respect to the assignment of responsibilities for carrying out specific actions. For air shipments, the International Civil Aviation Organization's (ICAO) Technical Instructions for the Safe Transport of Dangerous Goods by Air [2] and the International Air Transport Association's Dangerous Goods Regulations [3] should be consulted, with particular regard to the State and operator variations. For sea shipments, the International Maritime Organization's International Maritime Dangerous Goods (IMDG) Code [4] should be consulted. Some countries have adopted the Transport Regulations by reference while others have incorporated them into their national regulations with possibly some minor variations.

103.2. The Transport Regulations have been developed over many years of consensus building among IAEA Member States and international transport and standards organizations (including IMO, ICAO, United Nations Economic Commission for Europe, Universal Postal Union and the International Organization for Standardization (ISO)). These bodies used internationally accepted scientific principles, data and research in establishing the Transport Regulations. The Transport Regulations are intended to provide countries and modal regulatory organizations

with consensus based transport requirements that protect the health and safety of workers, the public and the environment, and permit international commerce.

103.3. While the Transport Regulations are non-binding for adoption or implementation by States, the adoption and incorporation of the Transport Regulations by the international transport regulatory organizations does make compliance by States mandatory.

103.4. The Transport Regulations are based, therefore, on the presumption that a national infrastructure is in place, enabling the government to discharge its responsibilities for transport safety.

103.5. The current level of safety in the transport of radioactive material has been achieved on a worldwide basis through adoption of the Transport Regulations in international, regional and modal regulations for the transport of all dangerous goods, in which radioactive material is just one (Class 7) of the nine classes of dangerous goods. Related publications explain the Transport Regulations and provide advice on how they may be applied and cover topics such as emergency response, compliance assurance, management system and schedules of provisions (TS-G-1.2, TS-G-1.5, TS-G-1.4 and SSG-33, respectively) in greater detail.

103.6. The Transport Regulations are also recommended for adoption by Member States in their national regulations for transport of dangerous goods. Even Member States that do not have a nuclear power industry need to establish requirements to safely control the transport of radioactive material in common use, for example in medical, industrial or research applications.

103.7. Essential parts of a transport safety national infrastructure are: legislation and regulations, a competent authority empowered to authorize and inspect regulated activities and to enforce the legislation and regulations, sufficient financial resources and adequate numbers of trained personnel. The infrastructure should also provide means for addressing societal concerns that extend beyond the legal responsibilities of the persons authorized to conduct the transport of radioactive material.

103.8. In the 2018 Edition of the Transport Regulations (current edition), the following major changes are introduced, i.e. as compared to the 2012 Edition (previous edition):

- (a) The concept of Dual Purpose Cask (DPC) is incorporated as “shipment after storage”;
- (b) Provisions for shipment of SCO-III, i.e. transport of unpackaged large objects, are provided;
- (c) The requirement for the design of the package to take into account ageing mechanisms is specified;
- (d) The requirement for protection of the plug on UF₆ cylinders is strengthened;
- (e) The leaching test is deleted from the requirements for LSA-III material;
- (f) Seven radionuclides are added in Table 2.

As the 2018 Edition of the Transport Regulations is considered as a “new” edition since the 1996 Edition, transitional arrangements are provided for packagings designed under the 1985 Edition, 1996 Edition and subsequent Editions of the Transport Regulations up to the 2012 Edition. The transitional arrangements for the 1973 Edition are obsolete.

OBJECTIVE

104.1. In general, the Transport Regulations aim to provide a uniform and adequate level of safety that is commensurate with the inherent hazard presented by the radioactive material being transported. To the extent feasible, safety features are required to be built into the design of the package. By placing primary reliance on the package design and preparation, the need for any special actions during carriage (i.e. by the carrier) is reduced. Nevertheless, some operational controls are required for safety purposes. In addition, appropriate arrangements for planning and preparing emergency response should be made, with the aim of mitigating the radiological consequences that might occur in the event of reasonably foreseeable accidents (including events with a severity that exceeds that of the accident conditions of transport described in para. 106.5).

SCOPE

106.1. Transport includes carriage by a common carrier or by the owner of the radioactive material (or the owner's employee) where the carriage is incidental to the use of the radioactive material, such as vehicles carrying radiography devices being driven to and from the operations site by the radiographer, vehicles carrying density measuring gauges being driven to and from the construction site, and oil well logging vehicles carrying measuring devices containing radioactive material and radioactive material used in oil well injections.

106.2 In-transit storage is a part of shipment that is regulated by the Transport Regulations. Storage in a transport package, which may be over a time span of several years or decades, means the holding of radioactive material in a package that provides for its containment, with the intention of retrieval (for spent fuel see also SSG-15 [4bis1], and for radioactive waste see also WS-G-6.1 [4bis2]). Storage that precedes shipment is regulated by international and/or national storage regulations and is out of the scope of the Transport Regulations. Shipment after storage is regulated by the Transport Regulations; it is a specific shipment operation that requires consideration of ageing of package components, as well as changes in the Transport Regulations and changes of technical knowledge during the period of storage.

106.3. The scenario referred to as 'routine conditions of transport' is intended to cover the everyday use and transport of packages in which there are no minor mishaps or damaging incidents to the packages (incident free). However, a package, including its internal and external restraint systems, is required to be capable of withstanding the effects of the transport accelerations described in para. 613.1. (Appendix IV, Tables IV.1 and IV.2, detail the typical accelerations that may be applied.)

106.4. The scenario referred to as 'normal conditions of transport' is intended to cover situations in which the package is subjected to mishaps or incidents (minor mishaps) that range in severity up to the applicable test requirements for the package type concerned (i.e. Type IP-2, Type IP-3 or Type A). For example, the normal conditions of a free drop test for a Type A package is intended to simulate the type of mishap that a package would experience if it were to fall off the platform of a vehicle or if it were dropped during handling. In most cases packages would be relatively undamaged and would continue their journey after having been subjected to these minor mishaps.

106.5. The scenario referred to as 'accident conditions of transport' is intended to cover situations in which the package is subjected to incidents or accidents that range in severity between those having a severity greater than that covered by normal conditions of transport, up

to the maximum severity levels imposed under the applicable test requirements for the type of package concerned (i.e. up to the damage severity resulting from the applicable tests for accident conditions of transport detailed in paras 726–737). On the assumption that Type B(U) or Type B(M) packages are likely to be used in all modes of transport, Type B(U) or Type B(M) test requirements are intended to take into account a large range of accidents for land, sea and air transport that can expose packages to severe dynamic forces, although the severity levels indicated by the test criterion are not intended to represent a worst case accident scenario. The potentially more severe accident forces in an air transport accident are taken into account by the Type C test requirements.

107.1. The Transport Regulations are not intended to be applied to:

- (a) Radioactive material that forms an integral part of a means of transport, such as depleted uranium counterweights or tritium exit signs used in aircraft;
- (b) Radioactive material in persons or animals for medical or veterinary purposes, such as cardiac pacemakers or radioactive material introduced into humans or animals during diagnostic or therapeutic procedures; or
- (c) Radioactive material in or on a person who is to be transported for medical treatment because the person has been subject to accidental or deliberate intake of radioactive material or to contamination.

The treating physician, medical practitioner or veterinarian should give appropriate advice on radiological safety. Skin decontamination of persons should be considered prior to their transport, the delay in transporting the person due to decontamination does not introduce an additional hazard to the person's health

107.2. Consumer products are items available to the public as the end user without further control or restriction. These may be devices such as smoke detectors, luminous dials or ion generating tubes that contain small amounts of radioactive substances. Consumer products are outside the scope of the Transport Regulations only after sale to the end user. Any transport, including the use of conveyances between manufacturers, distributors and retailers, is within the scope of the Transport Regulations to ensure that large quantities of individually exempted consumer products are not transported in an unregulated manner.

107.3. The principles of exemption and their application to the transport of radioactive material are dealt with in para. 402.

107.4. The scope of the Transport Regulations does not include ores and natural or processed materials containing naturally occurring radionuclides provided that the activity concentration of the materials does not exceed 10 times the exempt activity concentration values (Table 2 or calculated in accordance with paras 403–407). Natural materials and ores are any physical matter that comes from the ground; minerals that can be extracted from them are also considered to be natural material. Examples of natural materials and ores include tantalite and tin slag, phosphate, potash, zirconium (zircon sands) and other materials for the ceramics industries, scales from oil and gas extraction industries, coal and coal ash, wastes from rare earths extraction, and ore and waste material from uranium mines.

Following the conclusion of the IAEA Coordinated Research Project (CRP) on Regulatory Control for the Safe Transport of Naturally Occurring Radioactive Material (NORM) [5], it was agreed that this exclusion does not depend on the prior or intended use of the material, i.e.

whether it is to be used for its radioactive, fissile or fertile radionuclides or not. The CRP modelling and analysis of realistic transport scenarios found that in cases when the provision of 10 times the exempt activity concentration values for this material is applied, the maximum annual dose from unregulated transport of the material would generally be substantially less than 1 mSv (referring to para. 71 of ICRP 104 [6], an annual dose criterion of 10 μ Sv does not apply to exposure situations involving natural sources, as this value is at least one or two orders of magnitude below the variability of the natural radiation background). GSR Part 3 [1] sets an annual dose limit of 1 mSv for exemption for NORM. The CRP concluded that the exclusion is appropriate from a radiation protection consideration and from a risk based regulatory consideration since the potential dose from the material during transport is dependent on the activity concentration of the material. Guidance for determining activity levels and basic nuclide values is provided in paras 403–407 for reference in the use of Table 2.

For ores and other natural or processed materials containing natural occurring radionuclides of the uranium–radium and/or thorium decay chain, the basic nuclide values for exempt activity concentration given in Table 2 for U(nat) and Th(nat) can only be used if the radionuclides are in secular equilibrium. If this is not the case, for example owing to processing activities such as chemical leaching or thermal treatment disturbing the natural radioactive equilibrium, the formula for mixtures of radionuclides in para. 405 has to be applied to calculate the exempt activity concentration.

For example, in terms of the Th-232 decay chain, the value of activity concentration for exempt material for Th-228 in Table 2 of the Transport Regulations is lower by a factor 10 than the value for Ra-228; consequently the overall activity concentration value for exempt material depends predominantly on the fraction of Th-228 in the nuclide mixture. This is further illustrated by the following example:

- In the process of extracting crude oil and natural gas, scales accumulate on the inner walls of the production pipes. The scales consist of barium sulphate in which radium isotopes (Ra-226 and Ra-228) co-precipitate; the parent nuclides (U-238, Th-232) are not present in the scale deposit. Accordingly, the secular equilibrium of the decay chains is disturbed.
- There is a slow ingrowth of Pb-210 and Po-210 from Ra-226 (equilibrium is reached after about 100 years), Th-228 also ingrows, eventually reaching an equilibrium of 1.46 times the Ra-228 activity concentration within a few years. For example, inserting measured activity concentrations, as provided in Ref. [7], into the formula in para. 405 leads to the following exempt activity concentration (sum activity):

$$f_{\text{Ra-226}} + f_{\text{Pb-210}} + f_{\text{Po-210}} + f_{\text{Ra-228}} = 0.84, \text{ and } f_{\text{Th-228}} = 0.16$$

- From this, it follows that $0.84/10 + 0.16/1 = 0.244$, and then $1/0.244 = 4.1$ Bq/g, which is the exempt activity concentration (i.e. based on the sum activity of all relevant radionuclides, where 10 Bq/g is the activity concentration limit for exempt material for Ra-226, Pb-210, Po-210 and Ra-228, and 1 Bq/g is the activity concentration limit for exempt material for Th-228). This value can now be multiplied by 10, in accordance with para. 107(f), to determine the activity concentration for exclusion.

There are natural materials and ores in which the activity concentration is much higher than the exemption values. The transport of these ores may require consideration of radiation protection measures. Hence, a factor of 10 times the exemption value for activity concentration was chosen as providing an appropriate balance between the radiological protection concerns and the

practical inconvenience of regulating large quantities of material with low activity concentrations of naturally occurring radionuclides.

107.5. For checking exemption levels for surface contamination, see para. 413.7.

108.1. Although the Transport Regulations provide for the requisite safety in transport without the need for specified routeing, the regulatory authorities in some Member States have imposed routeing requirements. In prescribing routes, normal and accident risks, both radiological and non-radiological, as well as demographic considerations should be taken into account. Policies embodied in the routeing restrictions should be based upon all factors that contribute to the overall risk in transporting radioactive material and not only on concerns for 'worst case' scenarios (i.e. 'low probability/high consequence' accidents). Since the authorities at the State, provincial or even local levels may be involved in routeing decisions, it may often be necessary to provide them with either evaluations to assess alternative routes or with simple methods that they can use.

108.2. In assessing the radiological hazards and ensuring that the routeing requirements do not detract from the standards of safety specified in the Transport Regulations, analyses using appropriate risk assessment codes should be undertaken. One such code that may be used is INTERTRAN [8]. This computer based environmental impact code is available for use by Member States. In spite of many uncertainties stemming from the use of a generalized model and the difficulty of selecting appropriate input values for accident conditions, this code may be used to calculate and understand, at least on a qualitative basis, the factors significant in determining the radiological impact due to routeing alternatives involving the transport of radioactive material. These factors are the important aspects that should be considered in any routeing decision. For routeing decisions involving a single mode of transport, many simplifying assumptions can be made and common factors can be assigned that result in easy to use relative risk evaluation techniques.

108.3. The consignor may also need to provide evidence that measures to meet the requirements for safeguards and physical protection associated with shipments of nuclear material (as defined in the Convention on the Physical Protection of Nuclear Material, INFCIRC/274 Rev.1 [9]) are complied with.

109.1. Additional measures may be required by regulatory agencies to provide appropriate security in the transport of radioactive material and to prevent unlawful acts involving the receipt, possession, use, transfer, alteration, disposal or dispersal of radioactive material, which cause, or are likely to cause, death or serious injury to any person or substantial damage to property. See Refs [9, 10], IAEA Nuclear Security Series No. 13 [11], IAEA Nuclear Security Series No. 26-G [12], IAEA Nuclear Security Series No. 14 [13] and IAEA Nuclear Security Series No. 9 [14], the Code of Conduct on the Safety and Security of Radioactive Sources [15] and Guidance on the Import and Export of Radioactive Sources [16].

109.2. The consignor may also need to provide evidence that measures to meet any requirements for the security of certain shipments of radioactive material are also complied with.

110.1. See paras 506.1–506.2 and 507.1–507.9.

REFERENCES TO SECTION I

- [1] EUROPEAN COMMISSION, FOOD AND AGRICULTURE ORGANIZATION OF THE UNITED NATIONS, INTERNATIONAL ATOMIC ENERGY AGENCY, INTERNATIONAL LABOUR ORGANIZATION, OECD NUCLEAR ENERGY AGENCY, PAN AMERICAN HEALTH ORGANIZATION, UNITED NATIONS ENVIRONMENT PROGRAMME, WORLD HEALTH ORGANIZATION Radiation Protection and Safety of Radiation Sources: International Basic Safety Standards, IAEA Safety Standards Series No. GSR Part 3, IAEA, Vienna (2014).
- [2] INTERNATIONAL CIVIL AVIATION ORGANIZATION, Technical Instructions for the Safe Transport of Dangerous Goods by Air, 2019-2020 Edition, ICAO, Montreal (2019).
- [3] INTERNATIONAL AIR TRANSPORT ASSOCIATION, Dangerous Goods Regulations, 59th Edition, IATA, Montreal (2018).
- [4] INTERNATIONAL MARITIME ORGANIZATION, International Maritime Dangerous Goods (IMDG) Code, 2016 Edition, IMO, London (2016).
- [4bis1] INTERNATIONAL ATOMIC ENERGY AGENCY, Storage of Spent Fuel, IAEA Safety Standards Series No. SSG-15, IAEA, Vienna (2012).
- [4bis2] INTERNATIONAL ATOMIC ENERGY AGENCY, Storage of Radioactive Waste, IAEA Safety Standards Series No. WS-G-6.1, IAEA, Vienna (2006).
- [5] INTERNATIONAL ATOMIC ENERGY AGENCY, Regulatory Control for the Safe Transport of Naturally Occurring Radioactive Material (NORM), IAEA-TECDOC-1728, IAEA, Vienna (2013).
- [6] INTERNATIONAL COMMISSION ON RADIOLOGICAL PROTECTION, Scope of Radiological Protection Control Measures, Publication 104, Elsevier, Amsterdam (2007).
- [7] GESELLSCHAFT FÜR ANLAGEN- UND REAKTORSICHERHEIT (GRS) mbH, Exposure of Transport Workers from the Transport of Most Important NORM in Germany, Rep. GRS-A-3541, GRS, Köln (2010).
- [8] INTERNATIONAL ATOMIC ENERGY AGENCY, INTERTRAN: A System for Assessing the Impact from Transporting Radioactive Material, IAEA-TECDOC-287, IAEA, Vienna (1983).
- [9] The Convention on the Physical Protection of Nuclear Material, INFCIRC/274/Rev.1, IAEA, Vienna (1980).
- [10] Amendment to the Convention on the Physical Protection of Nuclear Material, GOV/INF/2005/10-GC(49)INF/6, IAEA, Vienna, 2005).

- [11] INTERNATIONAL ATOMIC ENERGY AGENCY, Nuclear Security Recommendations on Physical Protection of Nuclear Material and Nuclear Facilities (INFCIRC/225/Revision 5), IAEA Nuclear Security Series No. 13, IAEA, Vienna (2011).
- [12] INTERNATIONAL ATOMIC ENERGY AGENCY, Security of Nuclear Material in Transport, IAEA Nuclear Security Series No. 26-G, IAEA, Vienna (2015).
- [13] INTERNATIONAL ATOMIC ENERGY AGENCY, Nuclear Security Recommendations on Radioactive Material and Associated Facilities, IAEA, Nuclear Security Series No. 14, IAEA, Vienna (2011).
- [14] INTERNATIONAL ATOMIC ENERGY AGENCY, Security in the Transport of Radioactive Material, IAEA Nuclear Security Series No. 9, IAEA, Vienna (2008).
- [15] INTERNATIONAL ATOMIC ENERGY AGENCY, Code of Conduct on the Safety and Security of Radioactive Sources, IAEA, Vienna (2004).
- [16] INTERNATIONAL ATOMIC ENERGY AGENCY, Guidance on the Import and Export of Radioactive Sources, IAEA, Vienna (2012).

Section II

DEFINITIONS

A₁ and A₂

201.1. See Appendix I.

Approval

204.1. A graded approach has been applied to the approval requirements in the Transport Regulations such that these requirements are commensurate with the hazards posed by the radioactive material to be transported or to be covered by a design approval. Approval is intended to ensure that the design or shipment meets the relevant requirements and that the controls required for safety are adequate for the country and for the circumstances of the shipment. Since transport operations and conditions vary between countries, application of the 'multilateral approval' approach provides the opportunity for each competent authority to satisfy itself that the shipment is to be properly performed, with due account taken of any specific national conditions.

204.2. The concept of multilateral approval applies to transport as it is intended to occur. This means that only those competent authorities through whose jurisdiction the shipment is scheduled to be transported are involved in its approval. Unplanned deviations that occur during transport and result in the shipment entering a country where the transport had not previously been approved would need to be handled individually. If an aircraft is scheduled to stop in a country, however, multilateral approval includes approval by the competent authority of that country (see para. 243.1).

204.3. Users of the Transport Regulations should be aware that a Member State may require in its national regulations that an additional approval be given by its competent authority for any special form radioactive material, Type B(U) or Type C package that is to be used for domestic transport on its territory, even if the design has already been approved in another country.

205.1. For unilateral approval, it is believed that the Transport Regulations take into account the transport conditions that may be encountered in any country. Consequently, only approval by the competent authority of the country of origin of the design is required.

Carrier

206.1. The term 'person' includes a corporate body as well as an individual (see also paras 3.7–3.9 of GSR Part 3 [1]).

Competent authority

207.1. The competent authority is the organization defined by legislative or executive authority to act on behalf of a country in matters involving the transport of radioactive material, or an international authority on such matters. The legal framework of a country determines how a national competent authority is designated and is given the responsibility to ensure application of the Transport Regulations. In some instances, authority over different aspects of the Transport Regulations is assigned to different agencies, depending on the transport mode (air, road, rail, sea or inland waterway) and on the package and

radioactive material type (excepted, industrial, Type A, Type B(U), Type B(M) and Type C packages; special form radioactive material, low dispersible radioactive material (LDRM), fissile material or uranium hexafluoride). A national competent authority may, in some cases, delegate the approval of package designs and certain types of shipment to another organization having the necessary technical competence. National competent authorities also constitute the competent authorities referred to in any conventions or agreements on the transport of radioactive material to which the country adheres.

207.2. The competent authority should make the consignors, carriers, consignees and public aware of its identity and how it may be contacted. This may be accomplished by publishing details of the organizational identity (e.g. department, administration, office), with a description of the duties and activities of the organization in question as well as mailing address, telephone number, facsimile number, and email address.

207.3. The primary source of competent authority identifications is the list of National Competent Authorities Responsible for Approvals and Authorizations in Respect of the Transport of Radioactive Material, which is maintained by the IAEA and is available on the IAEA Transport Safety web page <http://www-ns.iaea.org/downloads/rw/transport-safety/competent-authorities-list.pdf>. Each country should ensure that the listed information is current and accurate. The IAEA requests verification of this information annually, and prompt responses by Member States will ensure the continued value of this list.

207.4. Full and proper implementation of the Transport Regulations requires that a competent authority be established by the government to regulate transport safety. Such a competent authority should be provided with sufficient powers and resources for effective regulation and enforcement, and should be independent of any government departments and agencies that are carrying out transport of radioactive material. The competent authority should also be independent of registrants, licensees and the designers and manufacturers of the transport systems. The effective separation of responsibilities between the functions of the competent authority and those of any other party should be made clear so that the regulators retain their independence of judgement and decision making as safety authorities.

207.5. The general functions of the competent authority include the following: the assessment of applications for package design approval, the issue of approval certificates and the authorization of shipments where applicable, subject to certain specified conditions the conduct of periodic inspections to verify compliance with the conditions; and any necessary enforcement actions to ensure compliance with the Transport Regulations. An effective compliance assurance programme should, as a minimum, include measures related to review and assessment of package design, issue of approval certificates, and inspection and enforcement.

207.6. The powers of the inspectors of the competent authority should be well defined and consistency of enforcement should be maintained. The competent authority may need to provide guidance on how certain regulatory requirements are to be fulfilled for various transport activities.

207.7. The competent authority should encourage all parties to develop a safety culture that includes: individual and collective commitment to safety by workers, management and regulators; accountability of all individuals for protection and safety, including individuals at senior management level; and measures to encourage a questioning and learning attitude and to discourage complacency with respect to safety.

Compliance assurance

208.1. See paras 307.1–307.9.

Confinement system

209.1. The confinement system is that part of a package necessary to maintain the fissile material in the configuration that was assumed in the criticality safety assessment for an individual package (see para. 681). The confinement system could be (i) an inner receptacle with defined dimensions, (ii) an inner structure maintaining the outer dimension of a fuel assembly and any interstitial fixed poisons, or (iii) a complete package such as a package with no inner container. The confinement system consists of specified packaging components and the package contents. Although the confinement system may have the same boundary as the containment system, this is not always the case since the confinement system maintains criticality control whereas the containment system prevents leakage of radioactive material. Each competent authority is required to concur that the confinement system defined in the criticality safety assessment is appropriate for the package design, for both damaged and undamaged configurations (see para. 681).

Containment system

213.1. The containment system can be the entire packaging but, more frequently, it makes up a portion of the packaging. For example, in a Type A package, the containment system may be considered to be the vial containing the radioactive contents. The vial, its enclosing lead pot shielding and fibreboard box make up the packaging. The containment system does not necessarily include the shielding. In the case of special form radioactive material and LDRM, the radioactive material may be part of the containment system.

213.2. The containment system of the package design should be explicitly defined, including the containment boundary of the system and, in particular, seals and fixation devices. The containment boundary system should consider features such as vent and drain ports that could present a leakage path from the containment system. For package systems that have double or concentric seals, the containment system seal should be defined. Secondary containers, such as bags, boxes and cans, that are used as product containers or to facilitate handling of the radioactive material should not be considered part of the containment system with respect to meeting the requirements of para. 659. The containment system should be composed of engineered features whose design is defined in the drawings of the packaging.

213.3. The leaktightness requirement for a containment system in a Type B(U), Type B(M) or Type C package depends on the radiotoxicity of the radioactive contents; for example, for Type B(U) or Type C package under accident conditions, the loss of radioactive contents in a period of a week should not exceed a value of A_2 (or $10A_2$ for Kr-85). This connection to the A_2 value means that for highly toxic radionuclides such as plutonium and americium, the allowable volumetric leakage rate will be much lower than for low enriched uranium. However, if fissile material is able to escape from the containment system under accident conditions, it is required to demonstrate that the quantity that escapes is consistent with that assumed in the criticality safety assessment in applying para. 685(c) (see also 685.2).

Contamination

214.1. Contamination includes two types of radioactive material on surfaces or embedded in surfaces, namely, fixed contamination and non-fixed contamination. There is no definitive distinction between fixed and non-fixed contamination: for practical purposes, a distinction is made between contamination that remains in situ during routine conditions of transport (i.e. fixed contamination) and therefore cannot give rise to hazards from ingestion, inhalation or spreading, and non-fixed contamination, which may contribute to these hazards. The only hazard from fixed contamination is due to external radiation exposure, whereas the hazards from non-fixed contamination also include the potential for internal exposure from inhalation and ingestion as well as external exposure due to contamination of the skin should it be released from the surface. Under accident conditions, and under certain conditions such as weathering, fixed contamination may, however, become non-fixed contamination.

214.2. Contamination levels not exceeding 0.4 Bq/cm^2 for beta and gamma emitters and for low toxicity alpha emitters, or not exceeding 0.04 Bq/cm^2 for all other alpha emitters, can give rise only to insignificant exposure through any of the pathways described in para. 214.1.

214.3. Any surface with levels of contamination not exceeding 0.4 Bq/cm^2 for beta and gamma emitters and low toxicity alpha emitters or 0.04 Bq/cm^2 for all other alpha emitters is considered a non-contaminated surface in applying the Transport Regulations. For instance, a non-radioactive solid object with levels of surface contamination lower than the above levels is beyond the scope of the Transport Regulations and no requirement is applicable to its transport.

214.4. For checking levels of contamination, the measuring techniques referred to in para. 413.9 apply.

215.1. See paras 214.1–214.3.

216.1. See paras 214.1–214.3.

Criticality safety index

218.1. The criticality safety index (CSI) is a term defined for the first time in the 1996 Edition of the Transport Regulations. It is the main principle used for the purpose of criticality safety by limiting the accumulation of packages containing fissile material during transport and in-transit storage.

The CSI is a value obtained by dividing the number 50 by the value of N (see para. 686) or using the provisions of paras 674 and 675. The total CSI is required to be controlled in individual packages (see para. 526), consignments (see para. 525), conveyances, freight containers and overpacks (see paras 566(c) and 567) and in-transit storage (see paras 568 and 569). To facilitate such control, the CSI is required to be displayed on a label (see paras 541 and 542) that is specifically designed to indicate the presence of fissile material in the case of packages, overpacks or freight containers where the contents consist of fissile material not excepted under the provisions of para. 417.

218.2. In special cases, in the absence of CSI control, limits on the mass of accumulated fissile nuclides are applied for packages and consignments (see para. 417(c), (d) and (e)) where large safety margins have been judged adequate to prevent the potential for criticality.

Dose rate

220A.1. One of the limiting quantities in radiological protection with respect to the exposure of people is effective dose (the others being equivalent dose to the lens of the eye and to the skin (see Schedule III of GSR Part 3 [1]). As protection quantities are not directly measurable quantities, operational quantities, which are measurable, were created. The relevant Operational quantities are ambient dose equivalent for strongly penetrating radiation and directional dose equivalent for weakly penetrating radiation. The dose rate should be taken as the value of the ambient dose equivalent or directional dose equivalent, as appropriate. Ambient dose equivalent is used to control effective dose, and directional dose equivalent is used to control dose to the skin, the hands and feet and the lens of the eye [2].

220A.2. In some cases, consideration should be given to the possibility of an increase in dose rate as a result of the buildup of daughter nuclides during transport. In such cases, a correction should be applied to represent the highest dose rate envisaged during the transport.

220A.3. In mixed gamma and neutron fields, it may be necessary to make separate measurements. It should be ensured that the monitoring instruments being used are appropriate for the energy spectrum and dose rate being emitted by the radionuclide(s). The monitoring instruments used should be calibrated and the calibration of the instruments should be valid.

220A.4. Neutron monitoring instruments can have a significant energy dependence, such that the energy distribution of the neutrons to be measured can significantly affect the accuracy of the determination of dose rate. Ideally, the energy distribution of the neutrons used for calibration and the energy distribution of the neutrons to be measured should be similar. If these are significantly different, and if the energy dependence of the instrument and the energy distribution of the neutrons to be measured are known, the corresponding correction factor should be used.

220A.5. The Transport Regulations require that specific dose rates are not exceeded at the surfaces of packages and overpacks. In most cases, a measurement made with a hand-held monitoring instrument against the surface of the package indicates the reading at some distance away because of the physical size of the detector volume. The instrument used for the measurement of the dose rate should, where practicable, be small in relation to the dimensions of the package or overpack. Instruments that are large relative to the physical size of the package or overpack should not be used because they might underestimate the surface dose rate. Where the distance from the source to the instrument is large in relation to the size of the detector volume (e.g. a factor of five), the effect is negligible and can be ignored; otherwise the values in Table 1 should be used to correct the measurement. For radiographic devices where the source to surface distance is generally kept to a minimum, the effect is usually not negligible, and an allowance should be made for the size of the detector volume.

220A.6. When monitoring finned flasks or other packages, care should be taken where narrow radiation beams may be encountered. A detector with an area much larger than the cross-sectional area of the beam to be measured, will yield a proportionally reduced reading of dose rate because of averaging over the much larger detector area. An appropriate instrument should be chosen for the measurements.

220A.7. The dose rates determined should be absolute values, i.e. from the radioactive material consignment only. Consequently, the background dose rate in the area of measurement should be subtracted from measured values.

TABLE 1. CORRECTION FACTORS FOR VARIOUS PACKAGE AND DETECTOR SIZES

Distance between detector centre and package surface (cm)	Half linear dimension of package (cm)	Correction factor ^a
1	>10	1.0
2	10–20	1.4
	>20	1.0
5	10–20	2.3
	20–50	1.6
	>50	1.0
10	10–20	4.0
	20–50	2.3
	50–100	1.4
	>100	1.0

^a The instrument reading should be multiplied by the correction factor to estimate the dose rate at the surface of the package.

Exclusive use

221.1. The special features of an ‘exclusive use’ shipment are: that a single consignor makes the shipment and has, through arrangements with the carrier, sole use of the conveyance or large freight container; and that all initial, intermediate and final loading and unloading and shipment of the consignment are carried out only in strict accordance with directions from the consignor or consignee.

221.2. Since ordinary in-transit handling of the consignment under exclusive use will not occur, some of the requirements that apply to normal shipments can be relaxed. In view of the additional control exercised over exclusive use consignments, specific provision has been made for them that allows:

- (a) Use of a lower integrity industrial package type for low specific activity (LSA) material;
- (b) Shipment of packages with dose rates exceeding 2 mSv/h (but not more than 10 mSv/h) at the surface, or with a TI exceeding 10;
- (c) In a number of cases, an increase by a factor of two in the total CSI for packages containing fissile material.

Many consignors find that it is advantageous to make the necessary arrangements with the carrier to provide transport under exclusive use so that the consignor can utilize one or more of the above provisions.

221.3. In the case of packaged LSA material, the Transport Regulations take into account the controlled loading and unloading conditions that result from transport under exclusive use. The additional controls required under exclusive use are to be in accordance with instructions prepared by the consignor or consignee, where so required by the Transport Regulations (both of whom have full information on the load and its potential hazards), allowing some reduction in packaging strength. Since uncontrolled handling of the packages does not occur under exclusive use, the conservatism embodied in the normal LSA packaging requirements for handling has been relaxed, but equivalent levels of safety are to be maintained.

221.4. Packages are required to have appropriate limits on dose rate to protect the workers handling them. The imposition of exclusive use conditions and the control of handling during transport help to ensure that proper radiation protection measures are taken. By imposing restrictions and placing a limit on the dose rates around the vehicle, the dose rate around the package may be increased without significantly increasing the hazard.

221.5. Since exclusive use controls effectively prevent the unauthorized addition of radioactive material to a consignment and provide a high level of control over the consignment by the consignor, allowances have been made in the Transport Regulations to authorize more fissile material packages than for ordinary consignments.

221.6. For exclusive use of a conveyance or large freight container, the sole use requirement and the sole control requirement are the determining factors. Although a vehicle may be used to transport only radioactive material, this does not automatically qualify the consignment as exclusive use. In order to meet the definition of exclusive use, the entire consignment has to originate from or be controlled by a single consignor. This excludes the practice of a carrier collecting consignments from several consignors in a single vehicle. Even though the carrier is consolidating the multiple consignments onto one vehicle, it is not in exclusive use because more than one consignor is involved. However, this does not preclude a properly qualified carrier or consignee who is consolidating shipments from more than one source from taking on the responsibilities of the consignor for these shipments and from being so designated.

221.7. Annex III in Transport Regulations gives a list of consignments requiring exclusive use.

Fissile nuclides and fissile material

222.1. A fission chain is propagated by neutrons. Since a chain reaction depends on the behaviour of neutrons, fissile material is packaged and shipped under requirements designed to maintain subcriticality and thus provide criticality safety in transport.

222.2. Most radionuclides can be made to fission, but many can only be made to fission with difficulty and with the aid of special equipment and controlled conditions. The distinguishing characteristic of the fissile nuclides listed in the definition is that they are capable of supporting a self-sustaining thermal neutron (neutron energies less than approximately 0.3 eV) chain reaction by only the accumulation of sufficient mass. No other action, mechanism or special condition is required. For example, Pu-238 is no longer listed in the definition because, although it can be made to support a fast neutron chain reaction under stringent laboratory conditions, in the form in which it is encountered in transport it does not have this property. Pu-238 cannot, under any circumstances, support a chain reaction carried by thermal neutrons. It is therefore 'fissionable' rather than 'fissile'.

222.3. As indicated in para. 222.2, the basis used to select the nuclides defined as fissile for the purposes of the Transport Regulations relies on the ease of accumulating sufficient mass for potential criticality. Other nuclides that have the potential for criticality are discussed in Ref. [3] and subcritical mass limits are provided for isolated units of Np-237, Pu-238, Pu-240, Pu-242, Am-241, Am-242m, Am-243, Cm-243, Cm-244, Cm-245, Cm-247, Cf-249 and Cf-251. The predicted subcritical mass limits for these nuclides range from a few grams (Cf-251) to tens of kilograms. However, the lack of critical experimental data, limited knowledge of the behaviour of these nuclides under different moderator and reflection conditions and the uncertainty in the cross-section data for many of these nuclides require that adequate attention (and an associated subcritical margin) be provided to operations where sufficient quantities of these nuclides might be present (or produced by decay before or during transport). Advice from the competent authority should be sought on the need for, and means of, performing a criticality safety assessment as per the requirements of paras 673–686 whenever significant quantities of these nuclides are to be transported.

222.4. Fissile material means any material containing any of the fissile nuclides, excluding cases where, taking into account the physics properties and the current transport practices, a criticality risk is judged not to be credible. For any package containing material defined as fissile material, paras 417, 418 and 673 have to be applied.

222.5. Packages containing less than 0.25 g of fissile nuclides would need to accumulate in very large numbers (several thousands) before there is even the theoretical possibility of criticality. Additionally, the probability of there being a sufficiently large number of such packages so as to influence the criticality safety of a consignment with fissile packages under CSI control has been judged not to be credible.

222.6. The major justification for excluding a package with a maximum fissile nuclide mass of 0.25 g, is that a shipment of several thousands of such packages with essentially ‘pure’ (no additional neutron absorbing nuclides) fissile material has been assumed to be very unlikely. For instance, it is not envisaged as credible to transport several thousands of UO₂ pellets, with an enrichment of 3.5% U-235, containing around 0.25 g of U-235 per pellet, in individual packages with one pellet per package. Any indication of changed practices in the future needs to be observed and discussed. Packages with trace concentrations of fissile nuclides (e.g. wastes) are not a criticality safety problem, even in large quantities, if the mass limit per package is complied with.

222.7. Natural and depleted uranium that is unirradiated, or only irradiated in thermal reactors, are excluded from being defined as fissile material, but only if there is no other material containing fissile nuclides in the package. The fissile nuclides in natural and depleted uranium could increase the neutron multiplication of a package carrying other material containing fissile nuclides. Thus, when the package design or package contents are known to contain natural or depleted uranium, this has to be taken into account in the safety assessment and in the approval requirements. This is often the case for modern light water reactor fuel, which may contain axial end zones with natural or depleted uranium.

222.8. Separated from other fissile material, the likelihood of criticality for packages containing only natural or depleted uranium as part of the contents is not considered credible. For this reason, natural or depleted uranium is only defined as fissile when other fissile material is in the package.

222.9. Unpackaged natural and depleted uranium can be found in many shipments of slightly radioactive material. However, the transport of high purity natural or depleted uranium in the same conveyance as packages containing fissile material — and for a criticality safety concern to occur due to the uranium entering packages containing fissile material, by being mixed with fissile material escaping from such packages, by being dispersed between such packages or by being placed in the vicinity of fissile material in packages — is not considered credible.

222.10. Irradiation of natural or depleted uranium could increase the probability for the material to sustain a neutron chain reaction. The restriction to irradiation in thermal reactors is intended to avoid this potential problem. Operators wishing to use para. 222 to exclude irradiated natural or depleted uranium from the definition of fissile material should ensure that any processing after irradiation will not have increased its reactivity. Production of plutonium during irradiation is greater at the surface of a fuel rod than in the centre. The surface layer will have a significantly higher plutonium concentration than the average concentration throughout the fuel and can have criticality characteristics similar to those of low enriched uranium. If this surface layer has been separated from the bulk of the fuel then material containing it (e.g. cladding residues) may not be suitable for exclusion under para. 222.

222.11. The exclusion provisions of para. 222(a) and (b) also apply if a packaging contains unirradiated as well as irradiated (in thermal reactors only) natural and/or depleted uranium, e.g. as shielding material.

Freight container

223.1. The methods and systems employed in the trans-shipment of goods have undergone a transformation since about 1965; the freight container has largely taken the place of parcelled freight or general cargo, which was formerly loaded individually. Packaged and unpackaged goods are loaded by the consignor into freight containers and are transported to the consignee without intermediate handling. In this manner, the risk of damage to packages is reduced; unpackaged goods are consolidated into conveniently handled units and transport economies are realized. The container may perform the function of the packaging as allowed under para. 629. Types of freight containers may include:

- Standard or Dry-Cargo: completely enclosed with a base, side walls and a roof;
- Open-top: with a removable roof (canvas or metal) or without a roof;
- Platform: only the base with no side walls or a roof;
- Flat Rack: a platform with four corner posts or two end frames that may be collapsible.

“Platform” and “flat rack” may be called “open-sided”.

223.2 For flat rack freight containers (see Fig. 1), the volume of the rectangular prism encompassing the container structure may be used as the internal volume. For platform freight containers (see Fig. 1), the volume of the rectangular prism encompassing the platform and the height of the load may be used as the internal volume.

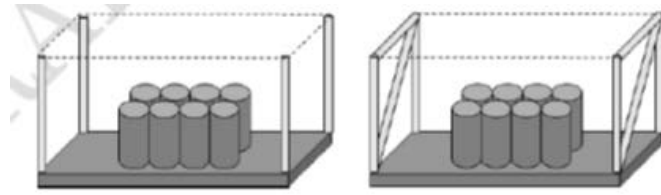

(A) For flat rack freight containers

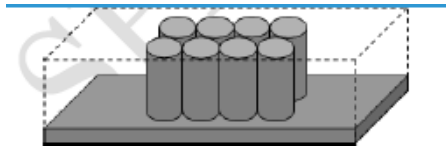

(B) For platform freight containers

FIG.1 Internal volume for open type freight containers

223.3. Freight containers are typically designed and tested in accordance with ISO standards [4]. Freight containers should be approved and maintained in accordance with Ref. [5] in order to facilitate international transport operations. It should be noted, however, that the testing prescribed in Ref. [5] is not equivalent to that prescribed in Ref. [4]. If other freight containers are used, the competent authority should be consulted.

223.4. In addition, special rules may be specified by modal transport organizations. As an example, the International Maritime Dangerous Goods Code [6] contains provisions for the transport by sea of dangerous goods in freight containers including radioactive material.

Low dispersible radioactive material

225.1. The concept of LDRM applies only to the qualification of the radioactive contents of a package for exemption from the requirements for Type C packages for transport by air.

225.2. LDRM has properties such that it will not give rise to significant potential releases or radiation exposures. Even when subjected to high velocity impact and thermal environments, only a limited fraction of the material will become airborne. Potential radiation exposure from inhalation of airborne material by persons in the vicinity of an accident would be very limited.

225.3. The LDRM criteria are derived in a manner that is consistent with other safety criteria in the Transport Regulations, as well as on the basis of established methods to demonstrate acceptable radiological consequences. The Transport Regulations require that the performance of LDRM be demonstrated without taking any credit for the Type B(U) or Type B(M) package in which it is transported.

225.4. LDRM may be the radioactive material itself, in the form of an indispersible solid, or a high integrity sealed capsule containing the radioactive material, in which the encapsulated material acts essentially as an indispersible solid. Powders and powder-like materials cannot qualify as LDRM.

Low specific activity material

226.1. The reason for the introduction of LSA material into the Transport Regulations was the existence of certain solid materials, the specific activities of which are so low that it is highly unlikely that, under circumstances arising during transport, a sufficient mass of such materials could be taken into the body to give rise to a significant radiation hazard. Uranium and thorium ores and their physical or chemical concentrates are materials falling into this category. This concept was extended to include other solid materials on the basis of a model that assumes that it is very unlikely that a person would remain in a dusty atmosphere long enough to inhale more than 10 mg of material. If the specific activity of this material is such that the intake represents an activity not more than that assumed to occur for a person involved in a median accident with a Type A package, namely $10^{-6}A_2$, then this material would not present a greater hazard during transport than that presented by a Type A package. This leads to an LSA material limit of $10^{-4}A_2/g$.

226.2. Consideration was given to the possibility of shipping solid objects without any packaging. The question arose for concrete blocks (with activity throughout the mass), for irradiated objects and for objects with fixed contamination. Under the condition that the specific activity is relatively low and remains in the object or fixed on the object's surface, the object can be dealt with as a package. For the sake of consistency and safety, the radiation limits at the surface of the unpackaged object should not exceed the limits for packaged material. Therefore, it was considered that if the limits on surface dose rates for packages (2 mSv/h for non-exclusive use and 10 mSv/h for exclusive use) are exceeded, the object should be packaged in an industrial package for which shielding is ensured in routine transport. Similar arguments were made for establishing surface contamination levels for unpackaged surface contaminated objects (SCOs).

226.3. The preamble to the LSA definition does not include the unshielded dose rate limit of 10 mSv/h at 3 m (see para. 517) because it is a property of the quantity of material placed in a single package rather than a property of the material itself (although in the case of solid objects that cannot be divided, it is a property of the solid object).

Low toxicity alpha emitters

227.1. The identification of low toxicity alpha emitters is based on the specific activity of the radionuclide (or the radionuclide in its 'as shipped' state). For a nuclide with a very low specific activity, its intake cannot, because of its bulk, be reasonably expected to give rise to doses approaching the dose limit. The radionuclides U-235, U-238 and Th-232 have specific activities four to eight orders of magnitude lower than Pu-238 or Pu-239 (4×10^3 to 8×10^4 Bq/g as opposed to 2×10^9 to 6×10^{11} Bq/g). Although Th-228 and Th-230 have specific activities comparable to those of Pu-238 and Pu-239, they are only allowed as 'low toxicity alpha emitters' when contained in ores and physical and chemical concentrates, which inherently ensures a low activity concentration.

Management system

228.1. The term 'management system' is defined in the IAEA Safety Glossary [13] and reflects and includes the concept of 'quality control' (controlling the quality of products) and its evolution through 'quality assurance' (the system for ensuring the quality of products) and 'quality management system' (the system for managing quality). The management system is

aimed at providing adequate confidence that the standard of safety prescribed in the Transport Regulations is achieved in practice.

228.2. In addition to internationally recognized standards dealing with quality management systems (e.g. ISO 9001:2015 [7]), IAEA Safety Standards Series No. GSR Part 2, Leadership and Management for Safety [8] establishes requirements for the management system.

228.3. Recommendations on how to comply with the requirements of the Transport Regulations with regard to the management system are provided in IAEA Safety Standards Series No. TS-G-1.4, The Management System for the Safe Transport of Radioactive Material [9].

Maximum normal operating pressure

229.1. The maximum normal operating pressure (MNOP) is the difference between the maximum internal pressure of the containment system and the mean sea level atmospheric pressure for the conditions specified in paras 229.2 – 229.4.

229.2. The environmental conditions to be applied to a package in determining the MNOP are the normal environmental conditions specified in paras 656 and 657 or, in the case of air transport, in para. 620. Other conditions to be applied in determining the MNOP are that the package is assumed to be unattended for a one year period and that it is subject to its maximum internal heat load.

229.3. A one year period exceeds the expected transit time for a package containing radioactive material; besides providing a substantial margin of safety in relation to routine conditions of transport, it also addresses the possibility of loss of a package in transit. The one year period is arbitrary, but has been agreed upon as a reasonable upper limit for a package to remain unaccounted for in transit. Since the package is assumed to be unattended for one year, any physical or chemical changes to the packaging or its contents that are transient in nature and could contribute to increasing the pressure in the containment system need to be taken into account. The transient conditions that should be considered include changes in heat dissipation capability, gas buildup due to radiolysis, corrosion, chemical reactions or release of gas from fuel pins or other encapsulations into the containment system. Some transient conditions may tend to reduce the MNOP, such as the reduction in pressure with time caused by a decrease in internal heat due to radioactive decay of the contents. These conditions may be taken into account if adequately justified.

229.4 The possible pressure build-up before shipment, in case of shipment after storage for instance, should be considered in the calculation of MNOP.

Overpack

230.1. The transport of a consignment from one consignor to one consignee may be facilitated by packing various packages or a single package, each of which fully complies with the requirements of the Transport Regulations, into one overpack, e.g. a box or bag. Specific design, test or approval requirements for the overpack are not necessary since it is the packaging that performs the protective function. The overpack is only a handling unit for convenience during transport. However, the interaction between the overpack and the packages should be taken into account, especially concerning the thermal behaviour of the packages during routine and normal conditions of transport.

230.2. A rigid enclosure or consolidation of packages for ease of handling in such a way that package labels remain visible for all packages need not be considered as an overpack unless advantage is taken by the consignor of the determination of the TI of the overpack by direct measurement of the dose rate.

Package

231.1. The terms ‘package’ and ‘packaging’ are used to distinguish the assembly of components for containing the radioactive material (packaging) from this assembly of components plus the contents (package).

231.2. As the package may be transported either with or without certain structural equipment, it may be necessary to evaluate both situations in determining packaging suitability and compliance.

231.3. If certain equipment is attached during transport for handling purposes, it may also be necessary to consider its effect in normal and accident conditions of transport. In the case of Type B(U), Type B(M), Type C and packages designed to carry fissile material, the designer has to reach agreement with the competent authority.

231.4. A tank, enclosed freight container or intermediate bulk container with radioactive contents may be used as one of the types of package under the Transport Regulations provided that it meets the prescribed design, test and any applicable approval requirements for that type of package. Alternatively, a tank, enclosed freight container or metal intermediate bulk container with radioactive contents may be used as an industrial package Type IP-2 or Type IP-3 if it meets the Type IP-1 requirements as well as other requirements that are referenced in paras 627–630 of the Transport Regulations.

Packaging

232.1. Other safety functions in this definition (see paras 231.1 and 231.2) include shielding, criticality control, prevention of damage due to heat and the functioning of those features necessary to enable the package to comply with the performance criteria specified in the Transport Regulations for routine, normal and accident conditions of transport as applicable to the package type.

232.2. For design and compliance assurance purposes, packaging may include any or all structural equipment necessary for handling or securing the package, which is either permanently attached or assembled as an integral part of the packaging.

232.3. In order to determine which structural components should be considered part of the packaging, it is necessary to examine the use and purpose of such equipment with respect to transport safety. If for safety purposes the packaging can only be transported with certain structures, then it is normal to consider those structures to be part of the packaging. This does not mean that a trailer or transport vehicle should be considered part of the packaging in the case of dedicated transport. A conveyance should not be considered part of the packaging, even in the case of dedicated transport.

Radioactive material

236.1. The radiation protection criteria defined in GSR Part 3 [1] are used to establish radionuclide specific exemption values (as listed in Table 2 of the Transport Regulations) for transport purposes (see para. 402.3).

236.2. The activity concentration value is that of the radioactive material within a package or any single inner containment system or receptacle of the package. The activity concentration is calculated for the radioactive material either alone or, if applicable, uniformly distributed throughout non-radioactive material. Calculation of the concentration should not take into account the mass of any packaging materials, nor should it take account of non-radioactive content that is not mixed with the radioactive material or susceptible to segregation from the radioactive material in routine conditions of transport. If the activity concentration varies across packages within the consignment or across inner containment systems or receptacles within the packages, the highest activity concentration should be considered as the activity concentration of the consignment.

236.3. The Transport Regulations are based on the assumption that a fissile material is always a radioactive material. However, the characteristics of a fissile material are based on completely different properties (fission probability and neutron multiplicity but not activity) than the characteristics of a radioactive material (activity, radiation type and energy). Whenever the specifications for classification of a material as radioactive are changed in the Transport Regulations, it is essential that the criticality potential is also addressed. The current limit for U-235 is judged to be sufficiently safe. A material with fissile nuclides other than those of U-235 could not have a potential for causing criticality while their activity concentrations and the total activities are below values specified in Table 2 of the Transport Regulations.

236.4. Radioactive material also means any object contaminated with radioactive substances where the contamination exceeds the levels in para. 214 and the total activity in the consignment exceeds the values specified in paras 402-407.

Shipment

237.1. In the context of the transport of radioactive material, the term ‘destination’ means the end point of a journey at which the package is, or is likely to be, opened, except during customs operations as described in para. 582.

Special arrangement

238.1. Special arrangement should be used only where it is impractical to ship under all the applicable requirements of the Transport Regulations. This type of shipment is intended for those situations where the normal requirements of the Transport Regulations cannot be met. For example, a special arrangement might be necessary for the disposal of old equipment containing radioactive material where there is no reasonable way to ship the radioactive material in an approved package. The hazard associated with repackaging and handling the radioactive material could outweigh the advantage of developing and using an approved package, assuming a suitable package could be made available. Another example could be a package design, approved under previous regulations, that cannot meet current regulations. In such a case, time would be needed to amend the package design (e.g. the development of a new design of impact limiters) and update the packaging, and might require special arrangement for the transport of packages under the previous package design in the meantime. The special arrangement provisions should compensate for not meeting all the requirements

of the Transport Regulations by providing an equivalent level of safety. In keeping with the underlying philosophy of the Transport Regulations, reliance on administrative measures should be minimized in establishing the compensating special arrangement measures. In any case, the number of shipments under special arrangement should be minimized.

Special form radioactive material

239.1. The Transport Regulations are based on the premise that the potential hazard associated with the transport of non-fissile radioactive material depends on four important parameters:

- (a) The dose per unit intake (by ingestion or inhalation) of the radionuclide;
- (b) The total activity contained within the package;
- (c) The physical form of the radionuclide;
- (d) The potential external dose rates.

239.2. The Transport Regulations acknowledge that radioactive material in an indispersible form or sealed in a strong metallic capsule presents a minimal contamination hazard, although the direct radiation hazard still exists. Material protected in this way from the risk of dispersion during accident conditions is designated as special form radioactive material. Radioactive material that is dispersible may be adsorbed, absorbed or bonded to an inert solid in such a manner that it acts as an indispersible solid, e.g. metal foils. See paras 603.1–603.4, 604.1 and 604.2.

239.3. Unless the radioactive contents of a package are in special form, the quantity of radioactive material that can be carried in an excepted or Type A package will be limited to A_2 or multiples thereof. For example, a Type A package is limited to A_2 and the contents of excepted packages are limited to values ranging from A_2 to as low as $10^{-4}A_2$, or $10^{-5}A_2$ if transported by post, depending upon whether the material is solid, liquid or gas and whether or not it is incorporated into an instrument or article. However, if the material is in special form, the package limits change from A_2 to A_1 or appropriate multiples thereof. Depending on the radionuclide(s) involved, the A_1 values differ from the A_2 values by factors ranging from 1 to 10 000 (see Table 2 of the Transport Regulations). The capability to ship an increased quantity in a package if it is in special form applies only to Type A and excepted packages.

Specific activity

240.1. The definition of specific activity in practice covers two different situations. The first, the definition of the specific activity of a radionuclide, is similar to the ICRU definition of specific activity of an element. The second, the definition of the specific activity of a material for the Transport Regulations, is more precisely an activity concentration (activity per unit mass). Thus, the definition of specific activity is given for both cases and depends upon its application in the requirements of the Transport Regulations. The term ‘activity concentration’ is also used in some paragraphs of the Transport Regulations (e.g. see para. 402 and the associated Table 2 of the Transport Regulations).

240.2. The half-life and the specific activity of each individual radionuclide given in Table 2 of the Transport Regulations are shown in Table II.1 of Appendix II. These values of specific activity were calculated using the following equation:

$$\text{Specific activity (Bq/g)} = \frac{(\text{Avogadro's number}) \times \lambda}{(\text{Atomic mass})} \quad (1)$$

$$= \frac{4.17 \times 10^{23}}{A \times T_{1/2}}$$

where

A is the atomic mass of the radionuclide;

$T_{1/2}$ is the half-life in s of the radionuclide;

λ is the decay constant in s^{-1} of the radionuclide = $\ln 2/T_{1/2}$.

240.3. The specific activity of any radionuclide not listed in Table II.1 of Appendix II can be calculated using the equation shown in para. 240.2.

240.4. The specific activity of uranium, for various levels of enrichment, is shown in Table II.3 of Appendix II.

240.5. In determining the specific activity of a material in which radionuclides are distributed, the entire mass of that material or a subset thereof (i.e. the mass of radionuclides and the mass of any other material) needs to be included in the mass component. The different interpretations of specific activity in the definition of LSA material (para. 226) and in Table II.1 should be noted.

Tank

242.1. The lower capacity limit on tank volume of 450 L is included to achieve harmonization with the current United Nations Recommendations [10].

242.2. Paragraph 242 includes solid contents in tanks; such contents are generally in powder or granulate form.

Through or into

243.1. The definition of multilateral approval is limited to countries “through or into which the consignment is transported” and specifically excludes countries over which an aircraft may carry the consignment provided that the aircraft has no scheduled stops in that country.

Transport index

244.1. The TI performs many functions in the Transport Regulations, including providing the basis for the carrier to segregate radioactive material from persons, undeveloped film, and other radioactive material consignments, and limiting the level of radiation exposure to members of the public and to transport workers during transport and in-transit storage.

244.2. Since the 1996 Edition of the Transport Regulations, the TI no longer makes any contribution to the control of the accumulation of packages containing fissile material for the purpose of criticality safety. Accumulation control for criticality safety is now provided by a separate CSI (see paras 218.1–218.2). Although the previous approach of a single control value for radiological protection and criticality safety provided for simple operational application, the current use of a separate TI and CSI removes significant limitations on segregation in the transport and storage in transit of packages not containing fissile material. The reason for retaining the designation of TI is that the vast majority of radioactive consignments do not include fissile material and, therefore, a new name for the ‘radioactive only’ TI could have created confusion because of the need to introduce and explain two new names. Care should be taken not to confuse the use of the TI value and to consider the CSI value as the only control for accumulation of packages for criticality safety.

244.3. See paras 523.4–524.1.

Unirradiated thorium

245.1. The term ‘unirradiated thorium’ in the definition of LSA material is intended to exclude any thorium that has been irradiated in a nuclear reactor so as to transform some of the Th-232 into U-233, a fissile material. The definition could have prohibited the presence of any U-233, but naturally occurring thorium may contain trace amounts of U-233. The limit of 10^{-7} g of U-233 per gram of Th-232 is intended to prohibit any irradiated thorium while recognizing the presence of trace amounts of U-233 in natural thorium.

Unirradiated uranium

246.1. The term ‘unirradiated uranium’ is intended to exclude any uranium that has been irradiated in a nuclear reactor so as to transform some of the U-238 into Pu-239 and some of the U-235 into fission products. The definition could have prohibited the presence of any plutonium or fission products, but naturally occurring uranium may contain trace amounts of plutonium and fission products. The limits of 2×10^3 Bq of plutonium per gram of U-235 and 9 MBq of fission products per gram of U-235 are intended to prohibit any irradiated uranium while recognizing the presence of trace amounts of plutonium and fission products in natural uranium.

246.2. The presence of U-236 is an indicator of exposure to a neutron flux and 5×10^{-3} grams of U-236 per gram U-235 has been chosen based on Ref. [11] for enriched commercial grade uranium. This value reflects the possibility of trace contamination by irradiated uranium, but ensures that the material may still be treated as unirradiated. This specification represents the composition with the maximum value for uranium radionuclides for which the A_2 value for uranium hexafluoride can be demonstrated as being unlimited. The difference in A_2 for uranium dioxide is considered to be insignificant [12].

REFERENCES TO SECTION II

- [1] EUROPEAN COMMISSION, FOOD AND AGRICULTURE ORGANIZATION OF THE UNITED NATIONS, INTERNATIONAL ATOMIC ENERGY AGENCY, INTERNATIONAL LABOUR ORGANIZATION, OECD NUCLEAR ENERGY AGENCY, PAN AMERICAN HEALTH ORGANIZATION, UNITED NATIONS ENVIRONMENT PROGRAMME, WORLD HEALTH ORGANIZATION Radiation Protection and Safety of Radiation Sources: International Basic Safety Standards, IAEA Safety Standards Series No. GSR Part 3, IAEA, Vienna (2014).
- [2] INTERNATIONAL COMMISSION ON RADIOLOGICAL PROTECTION, The 2007 Recommendations of the International Commission on Radiological Protection, ICRP publication 103, Ann. ICRP 37 (2-4), 2007.
- [3] AMERICAN NUCLEAR SOCIETY, Nuclear Criticality Control of Special Actinide Elements, Rep. ANSI/ANS-8.15-1981; R1987; R1995; R2005, (R = Reaffirmed), American Nuclear Society, La Grange Park, IL (2005).
- [4] INTERNATIONAL ORGANIZATION FOR STANDARDIZATION, Series 1 Freight Containers — Specifications and Testing — Part 1: General Cargo Containers for General Purposes, ISO 1496-1: 1990(E), ISO, Geneva (1990); and subsequent Amendments 1:1993, 2:1998, 3:2005, 4:2006 and 5:2006.
- [5] INTERNATIONAL MARITIME ORGANIZATION, International Convention for Safe Containers (CSC) 1972, As Amended 1993, IMO, London (1993).
- [6] INTERNATIONAL MARITIME ORGANIZATION, International Maritime Dangerous Goods (IMDG) Code, 2016 Edition, IMO, London (2016).
- [7] INTERNATIONAL ORGANIZATION FOR STANDARDIZATION, Quality Management Systems: Requirements, ISO 9001:2015, ISO, Geneva (2015).
- [8] INTERNATIONAL ATOMIC ENERGY AGENCY, Leadership and Management for Safety, IAEA Safety Standards Series No. GSR Part 2, IAEA, Vienna (2016).
- [9] INTERNATIONAL ATOMIC ENERGY AGENCY, The Management System for the Safe Transport of Radioactive Material, IAEA Safety Standards Series No. TS-G-1.4, IAEA, Vienna (2008).
- [10] UNITED NATIONS, Recommendations on the Transport of Dangerous Goods, Model Regulations, ST/SG/AC.10/1/Rev. 19, 2 vols, UN, New York and Geneva (2015).
- [11] ASTM C996-15, Standard Specification for Uranium Hexafluoride Enriched to Less Than 5% ²³⁵U, Developed by Subcommittee C26.02, ASTM International, West Conshohocken, PA, 2015.

- [12] INTERNATIONAL ATOMIC ENERGY AGENCY, Interim Guidance for the Safe Transport of Reprocessed Uranium, IAEA-TECDOC-750, IAEA, Vienna (1994).
- [13] INTERNATIONAL ATOMIC ENERGY AGENCY, IAEA Safety Glossary: Terminology Used in Nuclear Safety and Radiation Protection, 2018 Edition, IAEA, Vienna 2018.

Section III

GENERAL PROVISIONS

RADIATION PROTECTION

301.1. GSR Part 3 [1] establishes radiation protection requirements for planned exposure situations, including the transport of radioactive material. The system of radiation protection for planned exposure situations is based on the following principles:

- (a) No practice is to be adopted unless it produces a positive net benefit (Requirement 10: Justification of practices).
- (b) All exposures are to be kept as low as reasonably achievable, economic and social factors being taken into account (Requirement 11: Optimization of protection and safety).
- (c) Exposures to workers and members of the public are to be kept below dose limits established for occupational exposure and for public exposure, respectively (Requirement 12: Dose limits).

301.2. Optimization of protection and safety requires that both normal and potential exposures be taken into account. Normal exposures are exposures that are expected to be received under routine and normal transport conditions as defined in para. 106 of the Transport Regulations. Potential exposures are exposures that are not expected to be delivered with certainty but that may result from an accident or from an event or sequence of events of a probabilistic nature, including equipment failures and operating errors. In the case of normal exposures, optimization requires that the expected magnitude of individual doses and the number of people exposed be taken into account. In addition, in the case of potential exposures, the likelihood of occurrence of accidents or events or sequences of events should also be taken into account. The arrangements for implementing the optimization principle should be documented in the radiation protection programme (RPP): see IAEA Safety Standards Series No. GSG-7, Occupational Radiation Protection [2], IAEA Safety Standards Series No. TS-G-1.3, Radiation Protection Programmes for the Transport of Radioactive Material [3] and Ref. [4].

301.3. In practical radiation protection, there is a need to establish operational criteria based on quantities other than the dose limits. Criteria of this type are normally known as derived (or secondary) limits as they are related to the primary dose limits by a defined model. Examples of derived limits in the Transport Regulations include the maximum activity limits A_1 and A_2 , maximum levels for non-fixed contamination, dose rates at the surfaces of packages and in their proximity, and segregation distances associated with the TI. The Transport Regulations require assessment and measurement to ensure that such limits are being complied with.

301.4. Setting dose constraints is part of optimization: see para. 3.25 of GSR Part 3 [1] and Ref. [5]. The dose constraints described in GSR Part 3 should be used in relation to the transport of radioactive material. Dose constraints for public exposure should take into account exposures from other sources relevant to planned exposure situations.

302.1. The objectives of the RPP for the transport of radioactive material are:

- (a) To provide for adequate consideration of radiation protection measures in transport;

- (b) To ensure that the system of radiological protection is adequately applied;
- (c) To enhance a safety culture in the transport of radioactive material;
- (d) To provide practical measures to meet these objectives.

302.2. The RPP should include, to the extent appropriate, the following elements:

- (a) Scope of the programme (see paras 302.2–302.4);
- (b) Roles and responsibilities for the implementation of the programme (see para. 302.5);
- (c) Dose assessment and optimization (see para. 303);
- (d) Assessment of surface contamination (see paras 508, 513 and 514);
- (e) Segregation and other protective measures (see paras 562.1–562.14);
- (f) Emergency response arrangements (see paras 304, 305);
- (g) Training (see paras 311–315);
- (h) Management system (see para. 306).

Additional detailed guidance on the development and contents of an RPP for each of the above elements (a)–(h) is provided in TS-G-1.3 [3].

302.3. The scope of the RPP should include all the aspects of transport as defined in para. 106 of the Transport Regulations. However, it is recognized that in some cases certain aspects of the RPP may be covered in the RPPs at the consigning, receiving or storage in transit sites. Since the nature and extent of the measures to be employed in the RPPs will depend on the magnitude and likelihood of exposures, a graded approach should be followed.

302.4. Both the package type and the package category need to be considered. For routine transport, external radiation is an important consideration and the package category provides a classification for this. Under accident conditions, however, it is the package type (excepted, industrial, Type A, Type B(U), Type B(M) or Type C) that is important. Excepted, industrial and Type A packages are not required to withstand accidents. For those aspects of the RPP related to accident conditions of transport, the possibility of leakage from these package types as the result of transport or handling accidents will need to be considered. In contrast, Type B(U), Type B(M) and Type C packages can be expected to withstand all but the most severe accidents.

302.5. The external dose rates from excepted packages and category I-WHITE label packages are sufficiently low as to be safe to handle without restriction, and a dose assessment is therefore unnecessary. Consideration of radiation protection requirements can be limited to keeping handling times as low as reasonably achievable, and segregation can be met by avoiding prolonged direct contact of packages with persons and other goods during transport. A dose assessment will, however, be needed for persons that handle category II- and III-YELLOW label packages, and segregation, dose limits, constraints and optimization will need to be considered in light of this.

302.6. The RPP is best established through the cooperative effort of consignors, carriers and consignees engaged in the transport of radioactive material. Consignors and consignees should normally have an appropriate RPP as part of fixed facility operations. The role and responsibilities of the different parties and individuals involved in the implementation of the RPP should be clearly identified and described. Overlapping of responsibilities should be avoided. Depending on the magnitude and likelihood of radiation exposures, the overall responsibility for establishment and implementation of the RPP may be assigned to a 'qualified expert', i.e. an individual who, by virtue of certification by appropriate boards or societies, professional licence or academic qualifications and experience, is duly recognized as having expertise in a relevant field of specialization, e.g. radiation protection [1].

302.7. TS-G-1.3 [3] and Ref. [6] provide additional guidance on the development and implementation of RPPs and the monitoring and assessment of radiation doses. Practical information in relation to the implementation of RPPs for transport can be found in Refs [7–9].

303.1. GSR Part 3 [1] prescribes an effective dose limit of 1 mSv in a year for members of the public, and 20 mSv per year (averaged over five consecutive years and not exceeding 50 mSv in a single year) for workers. Dose limits for the lens of the eye, extremities (hand and feet), and skin, and for apprentices of 16 to 18 years of age, are also set out in GSR Part 3 [1], which also includes additional restrictions on the exposure of workers who are pregnant or breast-feeding. The dose limits and restrictions apply to all planned exposure situations, with the exception of medical exposures, and should be considered in the context of the requirements of para. 303.

303.2. Three categories for monitoring and assessing radiation doses result from para. 303. The first category (below the level specified in para. 303(a)) establishes a dose range where little action needs to be taken for evaluating and controlling doses. The upper value of this range is 1 mSv in a year, which was chosen to coincide with the dose limit for a member of the public. For this category, where it can be demonstrated that worker doses are most unlikely to exceed 1 mSv in a year, no special work patterns, detailed monitoring, dose assessment programmes or individual record keeping are necessary. The second category (the level specified in para. 303(a)) has an upper value of 6 mSv in a year, which is 3/10 of the limit on effective dose for workers (averaged over five consecutive years). This level represents a reasonable dividing line between conditions where dose limits are unlikely to be approached and conditions where dose limits could be approached. The third category (the level specified in para. 303(b)) is for any situation where the occupational exposure is likely to exceed 6 mSv per year. Consideration should also be given to the likelihood and possible magnitude of potential exposures.

303.3. Many transport workers are in the first category (less than 1 mSv in a year) and no specific measures concerning monitoring or control of exposure are necessary. For individuals falling into the second category (1–6 mSv in a year), a dose assessment programme is required. This may be based upon either individual monitoring or monitoring of the workplace. In the latter case, workplace monitoring may often consist of dose rate measurements in occupied areas at the start and at the end of a particular stage of a journey. In some cases, however, air monitoring, surface contamination checks and individual monitoring may also be required. In the third category (above 6 mSv in a year), individual monitoring is required. In most cases, this will be accomplished by the use of personal dosimetry such as film badges, thermoluminescent or optically stimulated luminescence dosimeters and, where necessary, neutron dosimeters (see GSG-7 [2]).

303.4. A correlation has been shown between the dose received by workers and the sum of the transport indexes for particular operations. Further guidance is given in TS-G-1.3 [3].

303.5. Given that relatively high dose rates are permitted during carriage under exclusive use, meaning that it would be relatively easy to exceed a dose of 1 mSv, additional care should be taken to ensure that the requirements of para. 303 are met by employing specific measures regarding monitoring or control of exposures. In the assessment of the overall individual exposure, any exposures received during the carriage phase of transport should be considered, together with those received elsewhere, particularly during loading and unloading.

EMERGENCY RESPONSE

304.1. The requirements established in the Transport Regulations, when complied with by the package designer, consignor, carrier and consignee, ensure a high level of safety for the transport of radioactive material. However, emergencies involving such packages may occur. Paragraph 304 of the Transport Regulations recognizes that planning and preparation are required to provide a sufficient and safe response to such emergencies. The response, in most cases, will be similar to the response to nuclear or radiological emergencies at fixed site facilities. Thus, it is required that relevant national or international organizations establish emergency procedures, and that these procedures be followed in the event of a nuclear or radiological emergency during transport of radioactive material.

304.2. Arrangements established by consignors and carriers include emergency plans and procedures for responding to nuclear or radiological emergencies during transport of radioactive material. At the operating organization level, they could conform to the plans and procedures for the transport of other dangerous goods and for conventional emergencies. They can be integrated with the arrangements for responding to other emergencies. Requirements for emergency preparedness and response are established in IAEA Safety Standards Series No. GSR Part 7, Preparedness and Response for a Nuclear or Radiological Emergency [10]. Further recommendations and guidance can be found in Refs [11–14].

304.3. Consignor and carrier arrangements for emergency preparedness and response should be available for inspection by the competent authority. They should assure an adequate collaboration between the different organizations involved in the emergency response. Establishing contacts with national authorities, providing them with technical information such as a description of the packaging and contents involved in the accident and providing support to the emergency response should have priority.

305.1. Consignors and carriers should develop arrangements, as appropriate, for emergencies during transport of radioactive material, in accordance with the graded approach. The contents of the arrangements should be commensurate with the magnitude of the hazard that may be presented during transport events. Modalities of transport should be considered when identifying potential consequences.

305.2. The radioactive hazard may not be the only potential hazard posed by the contents of a package. Other hazards may exist, including pyrophoricity, corrosivity or oxidizing potential or, if released, the contents may react with the environment (air, water), and produce hazardous substances. It is this latter phenomenon that para. 305 of the Transport Regulations addresses so as to ensure proper safety from chemical (i.e. non-radioactive) hazards. Specific attention is drawn to uranium hexafluoride because of its propensity to react, under certain conditions,

both with moisture in the air and with water, to form hydrogen fluoride and uranyl fluoride (HF and UO₂F₂, respectively).

305.3. In the event that the containment system of a package is damaged, air and/or water may reach and, in some cases, chemically react with the contents. For some radioactive material, these chemical reactions may produce caustic, acidic, toxic or poisonous substances that could be hazardous to people and to the environment. Consideration should be given to this problem in the design of the package and in emergency plan and the emergency procedures to reduce the consequences of such reactions. In doing so, the quantities of materials involved, the potential reaction kinetics, the mitigating effects of reaction products (self-extinguishing, self-plugging, insolubility) and the potential for concentration or dilution within the environment should all be considered. Such considerations may lead to restrictions on the package design or its use that go beyond considerations of the radioactive nature of the contents.

MANAGEMENT SYSTEM

306.1. A management system is essentially a systematic and documented method to ensure that the required conditions or levels of safety are consistently achieved. Any systematic evaluation and documentation of performance judged against an appropriate standard is a form of management system. A disciplined approach to all activities affecting quality, including, where appropriate, specification and verification of satisfactory performance and/or implementation of appropriate corrective actions, will contribute to transport safety and provide evidence that the required quality has been achieved.

306.2. The Transport Regulations do not prescribe a detailed management system because of the wide diversity of operational needs and the differing requirements of the competent authorities of each Member State. A framework upon which the management system may be based is provided in TS-G-1.4 [15]. The degree of detail in the management system will depend on the phase of the life of the package and the transport activity (e.g. mode of transport, type of package, frequency of transports), and should adopt a graded approach consistent with para. 104 of the Transport Regulations.

306.3. The establishment and implementation of the management system, as required by the Transport Regulations, should be carried out in a timely manner, before transport operations commence. Where appropriate, the competent authority will ensure that such a management system is implemented, as part of the timely adoption and application of the Transport Regulations.

306.4. The management system should address the design, manufacture, testing, documentation, use, maintenance and inspection of all special form radioactive material, LDRM, material approved under para. 417(f) and packages for transport and in transit storage operations. In particular, the manufacturer, consignor or user should be prepared to demonstrate that the manufacturing methods and materials used are in accordance with the approved design specifications, and that all packagings are periodically inspected and, as necessary, repaired and maintained in good condition so that they continue to comply with all relevant requirements and specifications, even after repeated use or at the time of shipment after storage.

306.5. A management system complying with an international standard such as ISO 9001 [16] and certified by an accredited agency may be acceptable for meeting the requirements of para. 306.

COMPLIANCE ASSURANCE

307.1. The adoption of transport safety regulations, based on the Transport Regulations, should be carried out within an appropriate time frame in Member States and by all relevant international organizations. Emphasis should be placed on the timely implementation of systematic compliance assurance programmes to complement the adoption of the Transport Regulations.

307.2. As used in the Transport Regulations, the term ‘compliance assurance’ has a broad meaning that includes all the measures applied by a competent authority that are intended to ensure that the requirements of the Transport Regulations are complied with in practice. Compliance means, for example, that:

- (a) Appropriate and sound packages are used;
- (b) The activity of radioactive material in each package does not exceed the regulatory activity limit for that material and that package type;
- (c) The dose rates external to, and the contamination levels on, surfaces of packages do not exceed the appropriate limits;
- (d) Packages are properly marked and labelled, and transport documents are complete;
- (e) The number of packages containing radioactive material in a conveyance is within the regulatory limits;
- (f) Packages of radioactive material are stowed in conveyances and are stored at a safe distance from persons and photosensitive material;
- (g) Only those stowage and lifting devices which have been tested are used in loading, conveying and unloading packages of radioactive material;
- (h) Packages of radioactive material are properly secured for transport;
- (i) Only trained personnel handle radioactive material packages during transport operations, including drivers of vehicles who may also load or unload the packages.

307.3. The principal objectives of a systematic programme of compliance assurance are:

- (a) To provide independent verification of regulatory compliance by the users of the Transport Regulations;
- (b) To provide feedback to the regulatory process as a basis for improvements to the Transport Regulations and the compliance assurance programme.

307.4. An effective compliance assurance programme should, as a minimum, include measures related to:

- (a) Review and assessment, including the issuance of approval certificates;
- (b) Inspection and enforcement.

307.5. A compliance assurance programme can only be implemented if its scope and objectives are conveyed to all parties involved in the transport of radioactive material (i.e. designers, manufacturers, consignors and carriers). Therefore, compliance assurance programmes should include provision for information dissemination. This should inform users regarding the way the competent authority expects them to comply with the Transport Regulations and about new developments in the regulatory field. All parties involved should use trained staff.

307.6. To ensure the adequacy of special form radioactive material (see para. 239 of the Transport Regulations) and certain package designs, the competent authority is required to assess these designs (see para. 802 of the Transport Regulations). In this way, the competent authority can ensure that the designs meet the regulatory requirements and that the requirements are applied in a consistent manner by different users. When required by the Transport Regulations, shipments are also subject to review and approval to ensure that adequate safety arrangements are made for transport operations.

307.7. The competent authority should perform audits and inspections as part of its compliance assurance programme to confirm that the users are meeting all applicable requirements of the Transport Regulations and are applying their management system. Inspections are also necessary to identify instances of non-compliance, which may necessitate either corrective action by the user or enforcement action by the competent authority. The primary purpose of an enforcement programme is not to carry out punitive action but to foster compliance with the Transport Regulations.

307.8. Since the Transport Regulations include requirements for provisions in the event of a nuclear or radiological emergency (see para. 304 of the Transport Regulations), a compliance assurance programme should include activities pertaining to emergency planning and preparedness and to emergency response when needed. These activities should be incorporated into the appropriate national emergency plans. The appropriate competent authority should also ensure that consignors and carriers have adequate emergency plans.

307.9. Further recommendations are given in IAEA Safety Standards Series No. TS-G-1.5, Compliance Assurance for the Safe Transport of Radioactive Material [17].

308.1. The competent authority assessments, including those that consider RPPs, may also be used to evaluate the effectiveness of the Transport Regulations, and may be part of the compliance assurance activities detailed in TS-G-1.5 [17] (see also paras 307.1–307.8). Of particular importance is the assessment of whether there is effective optimization of protection and safety. This may also help in achieving and maintaining public confidence.

308.2. To comply with para. 308 of the Transport Regulations, information on the radiation doses to workers and to members of the public should be collected and reviewed as appropriate. For example, reviews should be made if significant changes in transport patterns occur or when a new technology related to radioactive material is introduced. The collection of relevant information may be achieved through a combination of radiation measurements and assessments. Reviews of accident conditions of transport are necessary in addition to those of routine and normal conditions.

NON-COMPLIANCE

309.1. As a result of non-compliances with the requirements of the Transport Regulations for surface contamination, and the resulting cessation of transport of irradiated fuel shipments, the

IAEA convened two consultants' meetings in 1999 to deal with this issue. These were followed by a technical meeting in March 2000. It was recommended at these meetings that text addressing requirements for actions needed in the event of non-compliance be added to the Transport Regulations. In addition, the Transport Safety Standards Committee recommended that the IAEA undertake a coordinated research project (CRP) on contamination; the results can be found in Ref. [18].

309.2. The requirements of the Transport Regulations, when complied with by the consignor, carrier, consignee and any organization involved during transport, provide very high levels of safety for the transport of radioactive material. Paragraph 309 of the Transport Regulations recognizes that specific instances of non-compliance can occur. National and international organizations should establish programmes to investigate and analyse these events and institute remedial actions.

309.3. The term 'non-compliance' has a very broad meaning and includes all situations (except transport accidents) where a shipment is not in full accordance with the applicable regulatory requirements. The phrase "any limit applicable to dose rate or contamination" refers to all paragraphs in the Transport Regulations that contain limits on dose rates or contamination, including paras 423, 505, 508, 509, 513, 516, 517, 526–529, 566 and 573. In some countries, the competent authorities may decide to extend the requirement to other kinds of non-compliance and to the kind and severity of non-compliance that is required to be reported. In any case, consignors, carriers and any organization involved during transport have a prime responsibility to avoid recurrence of instances of non-compliance.

309.4. It is not the intention of para. 309 of the Transport Regulations to require carriers or consignees to measure contamination and dose rates during shipments.

309.5. An effective compliance assurance programme should, as a minimum, have objectives related to the detection and analysis of non-compliances, including:

- (a) Providing feedback to the regulatory process as a basis for improvements in the Transport Regulations and the compliance assurance (para. 307) programme;
- (b) Ensuring that adequate and appropriate communications and feedback are facilitated between the consignor, carrier, consignee, appropriate competent authority(ies) and any organization involved during transport who may be affected, concerning any non-compliance, to ensure that such occurrences are eliminated in the future.

SPECIAL ARRANGEMENT

310.1. The intent of para. 310 of the Transport Regulations is to permit the transport of consignments not satisfying all the specifically applicable requirements, but only under special arrangement. The requirement that the overall level of safety is at least equivalent to that which would be provided had all applicable provisions been met (see para. 104.1) should be accomplished by additional operational control or alternative means. Since the normally applicable regulatory requirements are not being satisfied, each special arrangement is required to be specifically approved by all competent authorities involved (i.e. multilateral approval is required).

310.2. The concept of special arrangement is intended to give flexibility to consignors to propose alternative safety measures that are effectively equivalent to those prescribed in the

Transport Regulations. This makes possible both the development of new controls and techniques to satisfy the existing and changing needs of industry in the longer term and the use of special operational measures for particular consignments where there may only be a short term interest. Indeed, the role of the special arrangement as a possible means of introducing and testing new safety techniques that can later be assimilated into specific regulatory provisions is also vital for the further development of the Transport Regulations.

310.3. It is recognized that unplanned situations may arise during transport, such as a package suffering minor damage or in some way not meeting all the relevant requirements of the Transport Regulations, which will require action to be taken. When there is no immediate health, safety or security concern, a special arrangement may be appropriate. Special arrangements should not be required to deal with occurrences of non-compliance that might require immediate transport to bring the non-compliant situation under appropriate health and safety controls. It is considered that the emergency procedures recommended in TS-G-1.2 [14] and the compliance assurance programmes recommended in TS-G-1.5 [17] provide better approaches in most cases for unplanned events of these types.

310.4. Approval under special arrangement can be sought in respect of shipments where variations from standard package design features result in the need to apply compensatory safety measures in the form of more stringent operational controls. Details of possible additional controls that can be used in practice for this purpose are included in para. 830.1. Information supplied to support equivalent safety arguments may comprise quantitative data, where available, and may range from considered judgement based on relevant experience to probabilistic risk analysis.

TRAINING

311.1. The provision of information and training is an integral part of any system of radiation protection. The level of instruction provided should be appropriate to the nature and type of work undertaken. Workers involved in the transport of radioactive material require training with respect to the radiological risks in their work and how they can minimize these risks in all circumstances.

311.2. Training should relate to specific jobs and duties, to specific protective measures to be undertaken in the event of an accident or to the use of specific equipment. It should include general information relating to the nature of radiological risk and knowledge of the nature of ionizing radiation, its effects and its measurement, as appropriate. Training should be a continuous commitment provided throughout employment and involves initial training and refresher courses at appropriate intervals. The effectiveness of the training should be periodically checked.

311.3. Information on specific training requirements has been published [19, 20].

312.1. The successful application of regulations concerning the transport of radioactive material and the achievement of their objectives are greatly dependent on the appreciation, by all individuals concerned, of the risks involved and on a detailed understanding of the Transport Regulations. This can only be achieved by properly planned and maintained initial and recurrent training programmes for all individuals concerned in the transport of radioactive material.

312.2. Paragraphs 312, 313 and 315 were introduced in the 2003 Edition of the Transport Regulations. Similar requirements can be found in the United Nations Model Regulations [21]; these provisions complement a uniform approach to training in the transport of dangerous goods.

312.3. Only appropriately trained persons should be engaged in the transport of radioactive material. The jobs and the associated duties and responsibilities should be clearly indicated in the descriptions of the organizations of the consignor, the carrier and the consignee. For other personnel, such as employees of the competent authority, independent inspectors and emergency personnel, it is also appropriate to specify their duties and responsibilities so that the necessary training can be determined and accomplished.

312.4. In addition to providing for the training of its own personnel, the competent authority should, as appropriate, specify and participate in the training of other persons involved in the transport of radioactive material. Furthermore, the competent authority should ensure through its compliance assurance programme and its monitoring of the management system that all the training needs of the organizations involved in transport are recognized and satisfied.

312.5. Further guidance and information on training of all personnel involved in the transport of radioactive material is given in Ref. [22].

314.1. Each organization should maintain adequate records of training plans and the performance of the individual trainees. Also, records should be maintained in accordance with the applicable management system requirements and should be examined or inspected periodically by the competent authority. The main purposes of these records are:

- (a) To provide to the competent authority or the regulatory body evidence of the appropriate qualifications of all persons whose duties have a bearing on safety, and evidence of the required authorizations;
- (b) To provide documentation that can be used in reviews of the training programme to enable the necessary corrective actions to be taken.

REFERENCES TO SECTION III

- [1] EUROPEAN COMMISSION, FOOD AND AGRICULTURE ORGANIZATION OF THE UNITED NATIONS, INTERNATIONAL ATOMIC ENERGY AGENCY, INTERNATIONAL LABOUR ORGANIZATION, OECD NUCLEAR ENERGY AGENCY, PAN AMERICAN HEALTH ORGANIZATION, UNITED NATIONS ENVIRONMENT PROGRAMME, WORLD HEALTH ORGANIZATION Radiation Protection and Safety of Radiation Sources: International Basic Safety Standards, IAEA Safety Standards Series No. GSR Part 3, IAEA, Vienna (2014).
- [2] INTERNATIONAL ATOMIC ENERGY AGENCY, Occupational Radiation Protection, IAEA Safety Standards Series No. GSG-7, IAEA, Vienna (2018).

- [3] INTERNATIONAL ATOMIC ENERGY AGENCY, Radiation Protection Programmes for the Transport of Radioactive Material, IAEA Safety Standards Series No. TS-G-1.3, IAEA, Vienna (2007).
- [4] INTERNATIONAL ATOMIC ENERGY AGENCY, Discussion of and Guidance on the Optimization of Radiation Protection in the Transport of Radioactive Material, IAEA-TECDOC-374, IAEA, Vienna (1986).
- [5] INTERNATIONAL ATOMIC ENERGY AGENCY, Optimization of Radiation Protection in the Control of Occupational Exposure, Safety Reports Series No. 21, IAEA, Vienna (2002).
- [6] NATIONAL RADIOLOGICAL PROTECTION BOARD, UK Guidance on Radiation Protection Programmes for the Transport of Radioactive Material, NRPB, Chilton, UK (2002).
- [7] WILSON, C.K., The air transport of radioactive materials, *Radiat. Prot. Dosim.* **48** 1 (1993) 129–133.
- [8] WILSON, C.K., SHAW, K.B., GELDER, R., “Radiation doses arising from the sea transport of radioactive materials”, *Packaging and Transportation of Radioactive Materials*, PATRAM 89 (Proc. Int. Symp. Washington, DC, 1989), Oak Ridge Natl Lab., TN (1989).
- [9] FAIRBAIRN, A., The development of the IAEA Regulations for the Safe Transport of Radioactive Materials, *At. Energy Rev.* **11** 4 (1973) 843.
- [10] FOOD AND AGRICULTURE ORGANIZATION OF THE UNITED NATIONS, INTERNATIONAL ATOMIC ENERGY AGENCY, INTERNATIONAL ATOMIC ENERGY AGENCY, INTERNATIONAL CIVIL AVIATION ORGANIZATION, INTERNATIONAL LABOUR ORGANIZATION, INTERNATIONAL MARITIME ORGANIZATION, INTERPOL, OECD NUCLEAR ENERGY AGENCY, PAN AMERICAN HEALTH ORGANIZATION, PREPARATORY COMMISSION FOR THE COMPREHENSIVE NUCLEAR-TEST-BAN TREATY ORGANIZATION, UNITED NATIONS ENVIRONMENT PROGRAMME, UNITED NATIONS OFFICE FOR THE COORDINATION OF HUMANITARIAN AFFAIRS, WORLD HEALTH ORGANIZATION, WORLD METEOROLOGICAL ORGANIZATION, Preparedness and Response for a Nuclear or Radiological Emergency, IAEA Safety Standards Series No. GSR Part 7, IAEA, Vienna (2015).
- [11] FOOD AND AGRICULTURE ORGANIZATION OF THE UNITED NATIONS, INTERNATIONAL ATOMIC ENERGY AGENCY, INTERNATIONAL LABOUR OFFICE, PAN AMERICAN HEALTH ORGANIZATION, WORLD HEALTH ORGANIZATION, Criteria for Use in Preparedness and Response for a Nuclear or Radiological Emergency, IAEA Safety Standards Series No. GSG-2, IAEA, Vienna (2011).

- [12] FOOD AND AGRICULTURE ORGANIZATION OF THE UNITED NATIONS, INTERNATIONAL ATOMIC ENERGY AGENCY, INTERNATIONAL LABOUR OFFICE, PAN AMERICAN HEALTH ORGANIZATION, UNITED NATIONS OFFICE FOR THE COORDINATION OF HUMANITARIAN AFFAIRS, WORLD HEALTH ORGANIZATION, Arrangements for Preparedness for a Nuclear or Radiological Emergency, IAEA Safety Standards Series No. GS-G-2.1, IAEA, Vienna (2007).
- [13] FOOD AND AGRICULTURE ORGANIZATION OF THE UNITED NATIONS, INTERNATIONAL ATOMIC ENERGY AGENCY, INTERNATIONAL CIVIL AVIATION ORGANIZATION, INTERNATIONAL LABOUR OFFICE, INTERNATIONAL MARITIME ORGANIZATION, INTERPOL, UNITED NATIONS OFFICE FOR THE COORDINATION OF HUMANITARIAN AFFAIRS, WORLD HEALTH ORGANIZATION, WORLD METEOROLOGICAL ORGANIZATION, Arrangements for the Termination of a Nuclear or Radiological Emergency, IAEA Safety Standards Series No. GSG-11, IAEA, Vienna (in press).
- [14] INTERNATIONAL ATOMIC ENERGY AGENCY, Planning and Preparing for Emergency Response to Transport Accidents Involving Radioactive Material, IAEA Safety Standards Series No. TS-G-1.2 (ST-3), IAEA, Vienna (2002). (A revision of this publication is in preparation)
- [15] INTERNATIONAL ATOMIC ENERGY AGENCY, The Management System for the Safe Transport of Radioactive Material, IAEA Safety Standards Series No. TS-G-1.4, IAEA, Vienna (2008).
- [16] INTERNATIONAL ORGANIZATION FOR STANDARDIZATION, Quality Management Systems: Requirements, ISO 9001:2015, ISO, Geneva (2015).
- [17] INTERNATIONAL ATOMIC ENERGY AGENCY, Compliance Assurance for the Safe Transport of Radioactive Material, IAEA Safety Standards Series No. TS-G-1.5, IAEA, Vienna (2009).
- [18] INTERNATIONAL ATOMIC ENERGY AGENCY, Radiological Aspects of Non-fixed Contamination of Packages and Conveyances, IAEA-TECDOC-1449, IAEA, Vienna (2005)
- [19] UNITED NATIONS ECONOMIC COMMISSION FOR EUROPE, INLAND TRANSPORT COMMITTEE, European Agreement Concerning the International Carriage of Dangerous Goods by Road (ADR), 2017 Edition, Chapter 8.2 and special provisions S11 and S12 in Chapter 8.5, UNECE, New York and Geneva (2016).
- [20] RIDDER, K., “The training of dangerous goods drivers in Europe”, Packaging and Transportation of Radioactive Materials, PATRAM 95 (Proc. Int. Symp. Las Vegas, 1995), United States Department of Energy, Washington, DC (1995).
- [21] UNITED NATIONS, Recommendations on the Transport of Dangerous Goods, Model Regulations, ST/SG/AC.10/1/Rev. 19, 2 vols, UN, New York and Geneva (2015).

- [22] INTERNATIONAL ATOMIC ENERGY AGENCY, Safe Transport of Radioactive Material, Training Course Series No. 1, IAEA, Vienna (2006).

Section IV

ACTIVITY LIMITS AND CLASSIFICATION

GENERAL PROVISIONS

401.1. The UN numbers, each of which is associated with a corresponding proper shipping name, have the function of identifying dangerous goods, either as single entries for well-defined substances or articles or in as generic entries for well-defined groups of substances or articles. The UN numbers for radioactive material were agreed through joint international cooperation between the United Nations Economic and Social Council's Committee of Experts on the Transport of Dangerous Goods (in 2001, the Committee was reconfigured and renamed "Committee of Experts on the Transport of Dangerous Goods and on the Globally Harmonized System of Classification and Labelling of Chemicals", with a dedicated "Sub-Committee of Experts on the Transport of Dangerous Goods") and the IAEA. The system of identification by means of numbers is preferable to other forms of identification using symbols or language owing to their relative simplicity in terms of international recognition. This identification is used for many purposes. UN numbers that are harmonized with other dangerous goods permit rapid and appropriate identification of radioactive goods within the broader transport environment of dangerous goods in general. Another example is the use of the UN numbers as a unique identification for emergency response operations. Each UN number is typically associated with a unique emergency response information table that permits first responders to refer to general advice in the absence of a specialist. During the first stages of an emergency, this prepared information can be more easily accessible to a wide group of non-specialist emergency responders (see also paras 546.1–546.5).

BASIC RADIONUCLIDE VALUES

402.1. The activity limitation on the contents of Type A packages (A_1 for special form material and A_2 for material not in special form) for any radionuclide or combination of radionuclides is derived on the basis that the radiological consequences following failure of the package after an accident are deemed to be acceptable, within the principles of radiological protection. The method of deriving A_1 and A_2 values is given in Appendix I.

402.2. The Transport Regulations do not prescribe limits on the number of Type A packages transported on a conveyance. It is not unusual for Type A packages to be transported together, sometimes in large numbers. As a result, it is possible for the source term in the event of an accident involving these shipments to be greater than the release from a single damaged package. However, it is considered unnecessary to constrain the size of the potential source term by limiting the number of Type A packages on a conveyance. Most Type A packages carry a small fraction of an A_1 or A_2 quantity; indeed, only a small percentage of consignments of Type A packages comprise more than the equivalent of one full Type A package. A study undertaken in the United Kingdom [1] found that the highest loading of a conveyance with Type A packages was equivalent to less than five full Type A packages. Experience also indicates that Type A packages perform well in many accident conditions. Combining event data from the USA [2] and the UK [3] over a period of about

20 years provides information on 22 accidents involving consignments of multiple Type A packages. There was a release of radioactive contents in only two of these events. Both led to releases of the order of $10^{-4}A_2$. A further example can be found in the description of an accident that happened in the USA in 1983 [4] with a conveyance carrying 82 packages (Type A and excepted) with a total activity equivalent to approximately $4A_2$ on board. Two packages were destroyed, releasing material with an activity of approximately $10^{-4}A_2$.

402.3. Table 2 of the Transport Regulations includes activity concentration limits and activity limits for exempting materials and consignments, respectively, from the requirements of the Transport Regulations, including applicable administrative requirements. If a material contains radionuclides where either the activity concentrations or the activity for the consignment is less than the limits in Table 2 of the Transport Regulations, then the shipment of that material is exempt (i.e. the Transport Regulations do not apply (see para. 236)). The general principles for exemption [5] are that:

- (a) The radiation risks to individuals caused by the exempted practice or source should be sufficiently low as to be of no regulatory concern;
- (b) The collective radiological impact of the exempted practice or source should be sufficiently low as not to warrant regulatory control under the prevailing circumstances;
- (c) The exempted practices and sources should be inherently safe, with no appreciable likelihood of scenarios arising that could lead to a failure to meet the criteria in (a) and (b).

402.4. Exemption values in terms of activity concentration and activity were initially derived for inclusion in the 1996 BSS² (usually, such basic radionuclide values are numerically equal to those given in Table I.1 of GSR Part 3 [5]) on the following basis [6]:

- (a) An individual effective dose of $10 \mu\text{Sv}$ in a year for normal conditions;
- (b) A collective dose of 1 man Sv in a year for normal conditions.

402.5. The exemption values were derived by using a variety of exposure scenarios and pathways that did not explicitly address the transport of radioactive material. Additional calculations were performed for transport specific scenarios [7]. These transport specific exemption values were then compared with the values in the 1996 BSS² (which are numerically equal to those given in Table I.1 of GSR Part 3 [5]). It was concluded that the relatively small differences between both sets did not justify the incorporation into the Transport Regulations of exemption values different from those in the 1996 BSS² given

² FOOD AND AGRICULTURE ORGANIZATION OF THE UNITED NATIONS, INTERNATIONAL ATOMIC ENERGY AGENCY, INTERNATIONAL LABOUR ORGANIZATION, OECD NUCLEAR ENERGY AGENCY, PAN AMERICAN HEALTH ORGANIZATION, WORLD HEALTH ORGANIZATION, International Basic Safety Standards for Protection against Ionizing Radiation and for the Safety of Radiation Sources, Safety Series No. 115, IAEA, Vienna (1996).

that the use of different exemption values in various practices may give rise to problems at interfaces and may cause legal and procedural complications.

402.6. Exemption values in terms of activity concentrations and activity were derived in the 1996 BSS^a and provided in Table I-1 of the 1996 BSS² (usually, such basic radionuclide values are numerically equal to those given in Table I-1 of GSR Part 3 [5]). The same exemption values are reproduced in Table 2 of the Transport Regulations.

402.7. For radionuclides not listed in the 1996 BSS², exemption values were calculated for the Transport Regulations by using the same method, as described in Ref. [6].

402.8. The activity concentration exemption values are to be applied to the radioactive material within a packaging or in or on a conveyance.

402.9. Exemption values for activity have been established for the transport of small quantities of material for which, when transported together, the total activity is unlikely to result in any significant radiological exposure, even when exemption values for activity concentration are exceeded. The exemption values for activity are therefore established on a per consignment basis rather than on a per package basis.

402.10. For radionuclides in which the decay chains have been taken into account (indicated by reference to footnote (b)), the values in Table 2, columns 4 and 5, of the Transport Regulations relate to the activity or activity concentration of the parent nuclide.

402.11. The exemption levels for radioactive substances are incorporated in the definition of radioactive material contained in para. 236 of the Transport Regulations.

DETERMINATION OF BASIC RADIONUCLIDE VALUES

403.1. For individual radionuclides that are not listed in Table 2 of the Transport Regulations, activity concentration limits for exempt material and activity limits for exempt consignments are calculated in accordance with the principles set out in GSR Part 3 [5]. As regards the methodology in Schedule I of GSR Part 3 [5], material may be exempted without further consideration provided that under all reasonably foreseeable circumstances the effective dose expected to be incurred by any member of the public from the exempted material is of the order of 10 μ Sv or less in a year. To take into account low probability scenarios, a different criterion could be used, namely, that the effective dose expected to be incurred by any member of the public for such low probability scenarios does not exceed 1 mSv in a year.

403.2. In the case of instruments and articles meeting the requirements of para. 423(c), alternative basic nuclide values for activity limits for an exempt consignment are permitted subject to multilateral approval.

403.3. Multilateral approval is required for alternative activity limits for an exempt consignment of instruments or articles. The information required to be submitted to the competent authority is listed in Para. 817 of the Transport Regulations. In addition, the following information should be included:

- (a) Description of the intended uses and benefits of the instrument or article, A description of the function served by the radionuclide;
- (b) Justification of the choice of a radionuclide, particularly in relation to other radionuclide(s) that could be of lower radiological toxicity (e.g. emit less penetrating radiation and/or have a shorter half-life). The reason for choosing the radioactive material in preference to a non-radioactive alternative should also be justified.
- (c) Description of the prototype tests for demonstrating the integrity of the product in normal use, and from misuse and damage, and the results of these tests.
- (d) Maximum external dose rates arising from the product and the measures taken for compliance assurance.

404.1. If A_1 or A_2 values need to be calculated, the methods outlined in Appendix I should be used. Two situations are considered here. First, for a radionuclide with a decay chain including one or more radionuclides in equilibrium in which the half-lives of all progeny (daughters) are less than 10 d and in which no progeny radionuclide has a half-life longer than the parent nuclide; and, second, any other situation. In the former case, only the parent radionuclide should be considered because the contribution of the daughters was considered in developing the A_1/A_2 values (see Appendix I) whereas, in the latter case, all the nuclides should be considered separately and as a mixture of radionuclides, in accordance with para. 405 of the Transport Regulations. In the particular case of Th(natural), U(natural), U(enriched to 20% or less) and U(depleted), contribution of all the nuclides of decay chains of Th-232, U-238 and U-235 were already considered for the determination of the “unlimited” A_1/A_2 value assigned to those entries in Table 2 independently of their half-lives.

405.1. See Appendix I.

405.2. Reactor plutonium recovered from low enriched uranium spent fuel (less than 5% U-235) constitutes a typical example of a mixture of radionuclides with known identity and quantity for each constituent. Calculations made in accordance with para. 405 of the Transport Regulations result in activity limits independent of the abundance of the plutonium radionuclides and the burnup within the range 10 000–40 000 MW·d/t. The following values for reactor plutonium can be used within the above range of burnup, the Am-241 buildup taken into account, up to five years after recovery:

$$A_1 = 20 \text{ TBq}$$

$$A_2 = 3 \times 10^{-3} \text{ TBq}$$

It is emphasized that these values can be applied only in the case of plutonium separated from spent fuel from thermal reactors, where the original fuel comprised uranium enriched up to 5% in U-235, where the burnup was not less than 10 000 MW·d/t and not more than 40 000 MW·d/t, and where the separation was carried out less than five years before the completion of the transport operation. It will also be necessary to consider separately other contaminants in the plutonium.

405.3. Calculation of the activity concentration for exempt material is only permitted in the case of a homogeneous mixture, since the models for determining these activity concentrations are based on the assumption that the isotopes are distributed uniformly throughout the material. The degrees of uniformity are further discussed in paras 409.1 and 409.10–409.14.

406.1. For mixtures of radionuclides where the identity of the nuclides is known but their relative proportions are not known in detail, a simplified method to determine the basic radionuclide values is given. This is particularly useful in the case of mixed fission products, which will almost invariably contain a proportion of transuranic nuclides. In this case, the grouping would simply be between alpha emitters and other emitters, using the most restrictive of the respective basic radionuclide values for the individual nuclides within each of the two groups. Knowledge of the total alpha activity and remaining activity is necessary to determine the activity limits on the contents. By using this method for the particular fission product mixture present, it is possible to take into account both the risk from transuranic elements and that from the fission products themselves. The relative risks will depend upon the origin of the mixture (i.e. the fissionable nuclide origin, the irradiation time, the decay time and possibly the effects of chemical processing).

406.2. For reprocessed uranium, A_2 values may be calculated by using the equation for mixtures in para. 405 and taking account of the physical and chemical characteristics likely to arise in both normal and accident conditions. It may also be possible to demonstrate that the A_2 value is unlimited by showing that 10 mg of the uranium will have less activity than that giving rise to a committed effective dose of 50 mSv for that mixture. In addition, for calculating A_2 values in the case of reprocessed uranium, the information given in Ref. [8] may be useful.

407.1. Table 3 of the Transport Regulations provides default data for use in the absence of known data. The values are the lowest possible within the alpha or beta–gamma subgroups. A_1 values of neutron emitters such as Cf-252, Cf-254 and Cm-248 are also taken into account.

407.2. In the 1985 Edition of the Transport Regulations, the radioactive contents presented in Table II were classified into two groups: “Only beta or gamma emitting nuclides are known to be present” and “Alpha emitting nuclides are known to be present or no relevant data are available”. In the 1996 Edition of the Transport Regulations, the radioactive contents were classified on the basis of A_1 values of neutron emitters into three groups: “Only beta or gamma emitting nuclides are known to be present”, “Only alpha emitting nuclides are known to be present” and “No relevant data are available”. However, the second description was not precise because all alpha emitters emit gamma rays or X rays after emitting alpha particles. In the 2005 Edition of the Transport Regulations, the second and third descriptions were amended to “Alpha emitting nuclide but no neutron emitters are known to be present” and “Neutron emitting nuclides are known to be present or no relevant data are available”, respectively.

CLASSIFICATION OF MATERIAL

Low specific activity (LSA) material

409.1. The preamble to the LSA definition (see para. 226.3) does not include wording regarding the need for an essentially uniform distribution of the radionuclides throughout the LSA material. However, it states clearly that the material should be in such a form that an average specific activity can be meaningfully assigned to it. In considering actual material shipped as LSA, it was decided that the degree of uniformity of the distribution should vary, depending upon the LSA category. The degree of uniformity is thus specified, as necessary, for each LSA category (e.g. para. 409(c)(i)). "Distributed throughout" means that the activity is not concentrated in a small part of the material but that a distribution of the activity exists over the whole material or parts of the material in a way that an average specific activity (activity per mass) can be meaningfully assigned to it. "Essentially uniformly distributed" means a more uniform distribution of radionuclides through the material than "distributed throughout". This term is applicable to material mixed with a solid compact binding agent (such as concrete, bitumen and ceramics) in order to solidify it. This could apply to materials such as powders or sludges that do not meet the requirements for classification as LSA-III by themselves. In this case, the controlled conditions of the mixing technology should ensure a roughly uniform activity distribution of the LSA-III material.

409.2. LSA-I was introduced in the 1985 Edition of the Transport Regulations to describe very low specific activity material. These materials may be shipped unpackaged or they may be shipped in industrial packages Type 1 (Type IP-1) that are designed to meet the requirements established in para. 623 of the Transport Regulations. According to para. 409(a)(i), LSA-I material can consist of concentrates of ores other than uranium or thorium concentrates (e.g. radium ore concentrate) if they do not meet the exclusion provisions of para. 107(f). In the 1996 Edition of the Transport Regulations, the LSA-I category was revised to take into account:

- (a) The clarification of the scope of the Transport Regulations concerning ores other than uranium and thorium ores, in accordance with para. 107(f);
- (b) Fissile material in quantities excepted from the package requirements for fissile material by virtue of one of the provisions in para. 417;
- (c) The introduction of new exemption levels in accordance with para. 236.

The definition of LSA-I was consequently modified to:

- (a) Include ores containing naturally occurring radionuclides that do not meet the exemption provisions of para. 107(f);
- (b) Exclude fissile material in quantities not excepted under para. 417 (para. 409(a)(iii));
- (c) Add radioactive material in which the activity is distributed throughout in concentrations up to 30 times the exemption level (para. 409(a)(iv)).

It is considered reasonable that materials containing radionuclides up to 30 times the exemption level may be exempted from parts of the Transport Regulations and may be associated with the category of LSA-I material. The factor of 30 has been selected to take account of the rounding procedure used in the derivation of the exemption levels in GSR

Part 3 [5] and to give a reasonable assurance that the transport of such material does not give rise to unacceptable doses.

409.3. The LSA material classification groups were developed with due consideration of the radiological hazard presented by the material. LSA-II or LSA-III material may contain fissile material. LSA-I material may only contain fissile material that is excepted by one of the provisions of subparagraphs (a) to (f) in para. 417.

409.4. The materials expected to be transported as LSA-II could include nuclear reactor process wastes that are not solidified, such as lower activity resins and filter sludges, absorbed liquids and other similar materials from reactor operations, and similar materials from other fuel cycle operations. In addition, LSA-II could include many items of activated equipment from the decommissioning of nuclear facilities.

409.5. While some of the materials considered to be appropriate for inclusion in the LSA-III category would be regarded as essentially uniformly distributed (such as concentrated liquids in a concrete matrix), other materials, such as solidified resins, are distributed throughout the matrix but are uniformly distributed to a lesser degree. The paras 409.6 to 409.15 provide guidance about the degree of uniformity of activity distribution which should be met to comply with the regulatory requirements for materials in the LSA-III category.

409.6. The provisions for LSA-III are intended principally to accommodate certain types of radioactive waste with an average estimated specific activity exceeding the $10^{-4}A_2/g$ limit for LSA-II material. The higher specific activity limit of $2 \times 10^{-3}A_2/g$ for LSA-III material is justified by:

- (a) Restricting such materials to solids, which are in a non-readily dispersible form, therefore explicitly excluding powders as well as liquids or solutions.
- (b) The requirement to use industrial package Type 3 (Type IP-3) (para. 625) under non-exclusive use conditions, which is essentially the same as a Type A package for solids.

409.7. The specific activity limit for LSA-II liquids of $10^{-5}A_2/g$, which is a factor of 10 more restrictive than the limits for solids, takes into account that the concentration of a liquid may increase during transport.

409.8. A solid compact binding agent, such as concrete or bitumen, which is mixed with the LSA material, is not considered to be an external shielding material. In this case, the binding agent may decrease the surface dose rate and may be taken into account in determining the average specific activity. However, if radioactive material is surrounded by external shielding material, which itself is not radioactive, as illustrated in Fig. 2, this external shielding material is not to be taken into account in determining the specific activity of the LSA material.

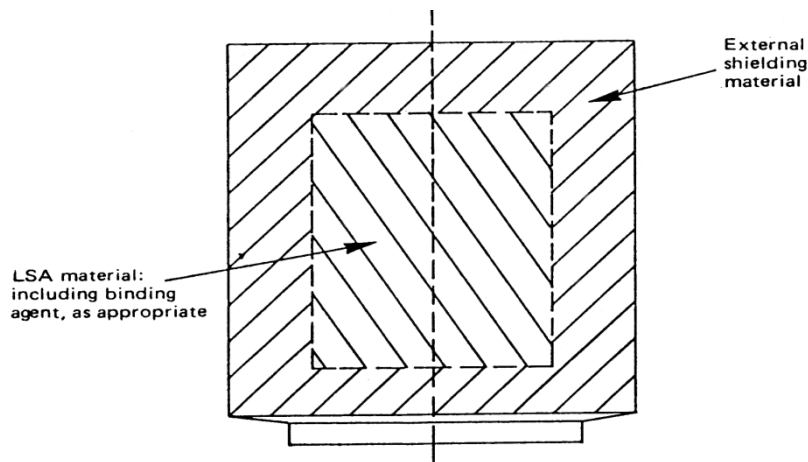

FIG. 2. LSA material surrounded by a cylindrical volume of non-radioactive shielding material.

409.9. For LSA-II solids, and for LSA-III material not incorporated into a solid compact binding agent, the Transport Regulations require that the activity be “distributed throughout” the material. This puts no requirement on how the activity is distributed throughout the material (i.e. the activity does not need to be uniformly distributed). It is, however, important to recognize that the concept of limiting the estimated specific activity fails to be meaningful if, in a large volume, the activity is clearly confined to a small percentage of that volume.

409.10. The consignor should ensure that the distribution of the activity in the LSA material is such that an average specific activity can be meaningfully assigned to it and that the majority of the activity is not confined to a small percentage of that volume. There are several methods that would be suitable for this purpose. The choice of the method should depend on knowledge about the LSA material and take into account the previous treatment of the material.

409.11. For material in which the activity is required to be ‘distributed throughout’ (LSA-II solids and LSA-III material not incorporated into a solid compact binding agent in order to solidify it), a simple method for assessing the average specific activity is to divide the volume occupied by the LSA material into defined portions and then to assess and compare the specific activity of each of these portions. A difference in specific activity between portions of a factor of less than ten should cause no concern. Justification that the allocation of portions is appropriate and that the material within each portion meets the expectation of “distributed throughout” should be produced. However, there is no need to compare the specific activity of each of these portions, provided that the estimated maximum average specific activity in any of these portions does not exceed the specific activity limit for solids. This is also applicable to para. 409.15.

409.12. Judgement needs to be exercised in selecting the size of the portions to be assessed. For volumes of material of more than 0.2 m³ it is suggested to divide the volume into 10 parts of approximately equal size on the following grounds: a possible airborne release of

respirable particles from LSA-II or LSA-III material suffering a severe impact comparable to the 9 m drop test will in most cases originate from those parts of the package where the impact occurs. The average specific activity within the partial volume that is subjected to the largest impact forces should accordingly not greatly exceed the specific activity limit for LSA-II or LSA-III material. Otherwise it would be conceivable that a severe impact occurs in such a way that just that portion of the LSA material that exceeds the allowed specific activity limit is the origin of an airborne release. Based on experimental experience from 9 m drops of LSA material onto an unyielding target it is a reasonable assumption that the size of the critical volume from which most of the airborne release originates is about 10% of the total LSA material in the package [9]. The local impact forces acting on the LSA material increase with the total mass of the package contents. Accordingly, the volume relevant for an airborne release is proportional to the mass (volume) of the package contents[6].

409.13. Based on the judgement by the consignor, for volumes of material of 0.2 m³ or less this method may reasonably be replaced by other assessments showing that the activity can be considered to be ‘distributed throughout’ and that there are no unacceptable concentrations of activity in small volumes to such an extent that the concept of limiting the estimated average specific activity fails to be meaningful.

409.14. For LSA-III materials consisting of radioactive material within a solid compact binding agent, the requirement is that they be essentially uniformly distributed in this agent. Since the requirement of ‘essentially uniformly distributed’ for LSA-III material is qualitative, it is necessary to establish methods by which compliance with the requirement can be judged.

409.15. The following method is an example for LSA-III materials for determining whether the radioactive material is essentially uniformly distributed in a solid compact binding agent. The method is to divide the LSA material volume, including the binding agent, into a number of portions. At least ten portions should be selected, subject to the volume of each portion being no greater than 0.1 m³. The specific activity of each volume should then be assessed (through measurements, calculations or combinations thereof). Specific activity differences between the portions of less than a factor of three should cause no concern. Justification that the allocation of portions is appropriate and that the material within each portion meets the expectation of “essentially uniformly distributed” should be produced. The factor of three in this procedure is more constraining than the suggested factor of ten in para. 409.11 because the ‘essentially uniformly distributed’ requirement is intended to be more constraining than the ‘distributed throughout’ requirement.

409.16. As a consequence of the definition of LSA material, additional requirements are specified for:

- (a) The quantity of LSA material in a single package, based on the external dose rate from the unshielded material (see para. 517 of the Transport Regulations);
- (b) The total activity of LSA material in any single conveyance (see para. 522 and Table 6 of the Transport Regulations).

The requirements in (a) and (b) can be much more restrictive than the basic requirements for LSA material given in para. 409. This can be seen from the following theoretical example: if it is assumed that a 200 L drum is filled with a solid combustible material with an estimated average specific activity of $2 \times 10^{-3} A_2/g$, this material could be transported as LSA-III. However, for example, if the density of the material is 1 g/cm^3 , the total activity in the drum will be $400A_2$ ($(2 \times 10^{-3} A_2/g) (1 \text{ g/cm}^3) (2 \times 10^5 \text{ cm}^3) = 400A_2$) and transport as LSA-III would be precluded by the conveyance limit of $10A_2$ by inland waterway and of $100A_2$ by other modes (see Table 6 of the Transport Regulations). (See para. 522.2.)

409.17. Objects that are both activated and contaminated cannot be considered as SCOs (see para. 413.5). However, such objects may qualify as LSA material since an object having activity distributed throughout and contamination distributed on its surfaces may be regarded as complying with the requirement that the activity be distributed throughout. For such objects to qualify as LSA material, it is necessary to ascertain that the applicable limits on estimated average specific activity are complied with. In assessing the average specific activity, all radioactive material attributed to the object (i.e. both the distributed activity and the activity of the surface contamination) needs to be included. As appropriate, additional requirements applicable to LSA material also need to be satisfied.

409.18. Small objects that are not themselves radioactive but contaminated on their surfaces (SCO) may qualify as LSA-II material provided that due to their sizes and arrangements within the packaging the activity can be considered as being “distributed throughout” and that an estimated average specific activity can be meaningfully assigned to them. This excludes components such as contaminated pumps or other large contaminated devices from being classified as LSA- II. SCO may not be classified as LSA-III to exclude the accumulation of unacceptable activity levels resulting from surface contaminations within the package.

409.19. Compaction of material should not change the classification of the material. To ensure this, the mass of any container compacted with the material should not be taken into account in determining the average specific activity of the compacted material.

409.20. See also Appendix I.

409.21. If the total activity of the LSA material does not exceed the activity limits for excepted packages specified in column 4 of Table 4 of the Transport Regulations, the LSA material can be transported in an excepted package provided that the requirements in para. 424 and all the applicable requirements and controls for transport of excepted packages (paras 515 and 516) are complied with.

411.1. See paras 517.1 and 522.1.

Surface contaminated object (SCO)

413.1. SCOs are, by definition, objects that are not radioactive but have radioactive material distributed on their surfaces. The implication of this definition is that objects that are themselves radioactive (e.g. activated objects) and are also contaminated cannot be classified as SCOs. Such objects may, however, be regarded as LSA material insofar as the

requirements for LSA material in the Transport Regulations are complied with (see also para. 409.17).

413.2. If the total activity of an SCO does not exceed the activity limits for excepted packages specified in Table 4 of the Transport Regulations, it can be transported **as-in-an** excepted package provided that the requirements in para. 423 or in para. 424 and all the applicable requirements and controls for transport of excepted packages (paras 515 and 516) are complied with.

413.3. A differentiation is made between SCO-I and SCO-II in terms of their contamination level, and this defines the type of packaging to be used to transport these objects. The Transport Regulations provide adequate flexibility for the unpackaged shipment of SCO-I objects or their shipment in an industrial package (Type IP-1). The higher level of non-fixed contamination permitted on objects classified as SCO-II requires the higher standard of containment afforded by industrial package Type IP-2.

413.4. The SCO-I model used as justification for the limits for fixed and non-fixed contamination is based on the following scenario. Objects in the category of SCOs include those parts of nuclear reactors or other fuel cycle equipment that have come into contact with primary or secondary coolant or process waste resulting in contamination of their surface with mixed fission products. On the basis of the allowable contamination levels for beta and gamma emitters, an object with a surface area of 10 m² could have fixed contamination up to 4 GBq and non-fixed contamination up to 0.4 MBq. During routine transport, this object can be shipped, unpackaged, under exclusive use, but it is necessary to secure the object (para. 520(a)) to ensure that there is no release of radioactive material from the conveyance. The SCO-I object and other cargo is assumed to move in an accident, such that 20% of the surface of the SCO-I object is scraped and 20% of the fixed contamination from the scraped surface is released. In addition, all of the non-fixed contamination is considered to be released. The total activity of the release would, thus, be 160 MBq for fixed contamination and 0.4 MBq for non-fixed contamination. Using an A₂ value of 0.02 TBq for mixed beta and gamma emitting fission products, the activity of the release equates to $8 \times 10^{-3}A_2$. It is considered that such an accident would only occur outside so that, consistent with the basic assumption of the Q system developed for Type A packages (see Appendix I), an intake of 10^{-4} of the scraped radionuclides for a person in the vicinity of the accident is appropriate. This would result in a total intake of $0.8 \times 10^{-6}A_2$. Hence this provides a level of safety equivalent to that for Type A packages.

413.5. The model for an SCO-II object is similar to that for an SCO-I object, although there may be up to 20 times as much fixed contamination and 100 times as much non-fixed contamination. However, an industrial package (Type IP-2) is required for the transport of SCO-II objects. The presence of this package will lead to a release fraction in an accident that approaches that for a Type A package. Using a release fraction of 10^{-2} results in a total release of beta and gamma emitting radionuclides of 32 MBq of fixed contamination and 0.4 MBq of non-fixed contamination, which equates to $2 \times 10^{-3}A_2$. Applying the same intake factor as in the previous paragraph leads to an intake of $0.2 \times 10^{-6}A_2$, thereby providing a level of safety equivalent to that of Type A packages.

413.6 An accessible surface is any surface that can readily be wiped by hand, using standard surface contamination measurement techniques. Any other surface that is not accessible

due to a design feature, barrier or closure that remains effective during routine conditions of transport is an inaccessible surface. As a guide, if a 300 cm² area could be reached by a person's hand, it is considered an accessible surface. The phrasing "by hand" is not meant to discourage the use of tools such as telescopic sampling instruments. The phrasing "standard surface contamination measurement techniques" is intended to imply methods similar to those used for demonstrating compliance with the package contamination limits in para. 508 of the Transport Regulations.

413.7 An accessible surface may be rendered inaccessible for transport by securely closing or blanking it off, such as in the following examples;

- (a) Large diameter pipes that are closed off at the ends;
- (b) A tool box or other piece of maintenance equipment that is securely closed;
- (c) A glovebox with the access ports blanked off;
- (d) Contaminated tools or other equipment inside a suitably strong intermediate container.

413.8 For SCO-III, external inaccessible surfaces, such as the narrow gap between manway covers and the component, are normally filled or closed out with weld material or caulk to prevent leakage of contamination during transport, as shown in Fig. 3:

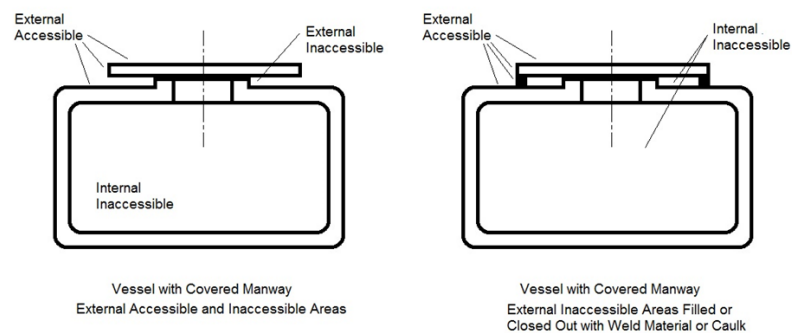

FIG. 3. Examples of external accessible and inaccessible areas.

413.9. Measurement techniques for fixed and non-fixed contamination of packages and conveyances are described in paras 508.2 and 508.7–508.12. These techniques are applicable to SCOs. However, to apply these techniques properly a consignor needs to know the composition of the contamination.

413.10. With regard to large objects generated from the refurbishment or decommissioning of nuclear facilities, over a hundred shipments have been conducted under special arrangements in the Member States [10–21]. These objects are generally very large, for example, measuring 6 m in diameter, 20 m in length and weighing 400 000 kg, and are not readily amenable to transport in accordance with the requirements for SCOs contained until the 2012 Edition of the Transport Regulations. While it was apparent that most of the objects transported contained only surface contamination, it was not certain that the SCO limits for inaccessible areas could be met, owing to non-uniform contamination deposition; nor could the interior areas be readily surveyed without on-site dismantling of the object.

These objects are generally substantial in design and construction, for example designed and manufactured to relevant codes as necessitated by their use as pressure vessels. If the objects need to be transported in packages that meet tests such as stacking and free drop tests, then this would incur severe engineering challenges, prohibitive costs, or logistical difficulties during transport, owing to the size and weight of the components being transported. As experience with this type of transport has grown and is now more routine, specific regulatory requirements were needed to allow the movement of large objects without the need for special arrangement. Based on this experience, a set of regulatory requirements for transport of large objects as surface contaminated objects (in a new SCO-III category), based on the IAEA “performance package” concept, have been developed and have been included in the 2018 Edition of the Transport Regulations.

413.11. For SCO-III, although openings are normally welded closed, such openings may be sealed (para. 413(c)(i)) by any method provided it is justified to prevent the release of the radioactive material during routine conditions of transport and the applicable tests for normal conditions of transport (See. para. 520(e)(iv)). Openings should be sealed such that they may only be opened by destructive techniques such as machining, sawing, drilling or flame cutting.

413.12. Though a threshold value for dryness is not given in para. 413(c)(ii), drain out of water, air blow and air ventilation are procedures employed to dry an object sufficiently for transport purposes. More stringent dryness specifications may be required for disposal.

413.13. For SCO-III, there is no specific limit for the levels of fixed contamination on the external surfaces, since similar to packages, the resulting external radiation will combine with the penetrating radiation from the contents, and the total dose rate is controlled by other specific requirements. The fixed contamination may not be able to be measured due to the dose rate emanating from the large object. However, if a significant fixed contamination on external surfaces is assumed, it should be reflected in the transport plan or the radiation protection program respectively. The majority of the component’s activity (A_2 quantity) will in most cases be due to surface contamination on interior surfaces, rather than on exterior surfaces.

413.14. For SCO-I, SCO-II and SCO-III, contamination on the inaccessible surface may be determined by conservative estimates and/or analysis by methods other than direct contamination measurements.

413.15. In the Q system (see Appendix I), five exposure pathways, i.e. external photon dose (Q_A), external beta dose (Q_B), inhalation dose (Q_C), skin and ingestion dose due to contamination transfer (Q_D) and submersion dose (Q_E) are considered. Among these, the inhalation dose (Q_C) can be taken as a major exposure route for SCO-III in the event of an accident, since most of the activity that is dispersed is from the contamination on the external surfaces that may be scratched during an accident. If a SCO-III is involved in an accident, the maximum intake of activity for a person in the vicinity of the accident should be no more than that accepted for Type A packages (see Appendix VII).

413.16. Transport of activated components, such as reactor vessels, is outside the scope of SCO-III.

414.1. See paras 517.1 and 522.1.

Fissile material

417.1. Paragraph 417 contains provisions whereby fissile material can be excepted from classification as “FISSILE”. Such excepted fissile materials are required to meet the specifications of the provisions, and the minimum level of control for transport required by para. 570, to ensure criticality safety. Detailed guidance for the application of these provisions are provided in Ref. [22]. Provisions (a) and (b) of para. 417 remain the same as in previous editions of the Transport Regulations. Provisions (c)–(e) of para. 417 remain the same as in the 2012 Edition of the Transport Regulations and provide a more restrictive limit on the allowed mass per package and the overall consignment (cf. para. 570) than allowed within the 2009 Edition of the Transport Regulations. The more restrictive limits reflect concerns regarding potential safety issues that might credibly be posed through accumulation of packages and/or consignments. For example, the historic exception that allowed 5 g of fissile nuclides in any 10 L volume did not include a requirement for non-fissile mass within the specified volume to help ensure mass dilution. For example, 5 g of fissile nuclides shipped within a 10 L volume containing polyethylene could present a potential hazard for a large volume transport and the polyethylene could also be readily lost in a fire during a potential accident. The current exceptions provided in para. 417(c)–(e) do allow small amounts of fissile mass per package and also limit consignment masses. However, the mass values are about a factor of 10 less than those allowed by the 2009 Edition of the Transport Regulations. This significant reduction in mass was judged as properly addressing any concerns with regard to potential accumulation that might practically be applied by consignors in the absence of control through the use of a CSI. Paragraph 417(f) enables individual Member States to certify a specific fissile material to be excepted from classification as FISSILE. However, the certificate is subject to multilateral approval.

417.2. The consignor will need to ensure that the mass of fissile material loaded in a package is within the mass limits specified by para. 417(c), (d) or (e) if the package is intended to be excepted from classification as FISSILE. If the mass limits are exceeded, the material could be transported (without competent authority approval) under para. 674, but a CSI value would need to be added to the label and it would be transported using an appropriate UN Number for fissile material.

417.3. The 1% enriched U-235 limit of para. 417(a) is a rounded value slightly lower than the minimum critical U-235 enrichment for infinite homogenous mixtures of uranium and water in Ref. [23]. The maximum enrichment should be no more than 1.0% by mass. The homogeneity addressed in para. 417(a) is intended to preclude latticing of slightly enriched uranium in a moderating medium. There is agreement that homogeneous mixtures and slurries are those in which the particles in the mixture are uniformly distributed and have a diameter no larger than 127 μm [24, 25]. For particle sizes greater than 127 μm , heterogeneous effects have been observed in certain mixtures; therefore, shippers of material such as powders where the grain size is likely to exceed this value should consider whether this exception is appropriate.

417.4. Paragraph 417(b) provides for the exception of uranyl nitrate solution enriched in U-235 to not more than 2% by mass of uranium. This limit is slightly lower than the

minimum critical enrichment value reported in Ref. [23]. This exception is dependent on the appropriate packaging of uranyl nitrate, which is necessary due to its corrosive properties. The essential criterion is that this material should be protected from environmental effects that would change the nitrogen:uranium ratio (N/U ratio) under normal conditions of transport.

417.5. Paragraph 417(c) is intended to provide a classification exception for limited quantities of uranium enriched in U-235 to a maximum of 5% by mass. The mass limit per package will continue to allow shipment of UF₆ samples based on historic practice. Assuming 10 g of UF₆ per sample tube and 10 tubes per package, the maximum mass value per package would be 3.5 g assuming a U-235 mass enrichment of 5% or less. A consignment limit of 45 g is specified in para. 570(c) for transport of these packages. This consignment limit is about 1/20 of the mass value that provides an adequate margin of subcriticality (see Table 13 of the Transport Regulations) and about 1/10 of the consignment limit provided in the 2009 Edition of the Transport Regulations. The package mass limit under this provision corresponds to a CSI value of 1.0 if the formula of para. 674(a) were to be applied and a CSI value of 0.4 if the formula of para. 674(b) were to be applied. However, only 13 packages loaded with the maximum 3.5 g would be allowed in a consignment.

417.6. Paragraph 417(d) follows the same concepts for safety as para. 417(c): a very small mass limit of 2 g per package, and the requirement in para. 570(d), which limits the mass per consignment to 15 g. This paragraph is intended to enable shipment of small samples of unirradiated or irradiated fissile material (e.g. spent fuel for research or testing purposes). Shipment of environmental samples (less than 2 g) with unknown masses of fissile material is another example of the need for this provision. The mass value of 2 g per package was derived to be consistent with the relative ratio of consensus mass values used as the subcritical mass values of Table 13. Thus, the ratio of 2 g in this provision to the 3.5 g in para. 417(c) is approximately the same as the ratio of the corresponding uranium mass values provided in Table 13. The package mass limits correspond to CSI values ranging from 0.4 (formula from para. 674(b) for U-235) to 1.1 (formula from para. 674(a) for U-235). Owing to the radioactive properties of Pu-239, mass values greater than 0.5 g would need to be shipped in Type B(U) or Type B(M) packages; thus assuming 2 g per package, the upper CSI value, corresponding to para. 674(b), would be 0.7. Therefore, allowing the same limit for all fissile nuclides is justified on the basis of the requirement for high integrity packaging if the mass of Pu to be shipped is greater than approximately 0.5 g. Again, the consignment limit of 15 g imposed on the consignor by para. 570(d) will mean that only 7 packages loaded with the maximum 2 g per package will be allowed in a consignment.

417.7. Paragraph 417(e) is provided to enable consignors to be granted an exception that will allow an exclusive use shipment of up to 45 g of fissile nuclides in one conveyance. The requirement for transport control (exclusive use) is provided in para. 570(e). This provision can be used for packaged and unpackaged material, such as small volumes of waste. This is the only provision in the Transport Regulations that allows unpackaged fissile material. The inclusion of exclusive use significantly limits the applicability (especially in air transport), thus necessitating the need for para. 417(c)–(d) for most shipments of material that might otherwise be transported using para. 417(e).

417.8. Paragraph 417(f) is a new concept introduced in the 2012 Edition of the Transport Regulations in order to provide individual Member States with a provision whereby

specifically defined fissile material may be excepted from classification as FISSILE provided the competent authority certifies the material is safe on the basis of the requirements of para. 606. This provision is needed because the nuclear fuel cycle processes undertaken by Member States are often sufficiently different that a variety of very low risk fissile materials are produced. The variety of methods used to process wastes provides a diversity of fissile material that has very different characteristics but typically the same low risk of criticality. Experience over the past two decades has demonstrated that it is not possible to develop general specifications or requirements that can properly cover the diversity of identified low risk fissile materials. Incorporating specifications for each of the large variety of exceptions known to exist would be prohibitive in the Transport Regulations. Shipment of material excepted under para. 417(f) by one Member State is required to have multilateral approval to be shipped to, or through, another Member State. An example of a Member State specific exception is contained in (b) and (c) in Ref. [26] (see para. 606.7).

418.1. Criticality safety can be sensitive to the quantity, type, form and configuration of fissile material, any fixed neutron poisons, and/or other non-fissile material included in the contents. Consequently, the contents of a package containing fissile material need to be as specified for the package design, either directly in the Transport Regulations (see paras 222, 417, 570, 674 and 675) or in the certificates of approval.

418.2. For approved package designs and materials approved in accordance with para. 606, care should be taken to include in the description of the authorized contents any material (e.g. inner receptacles, packing material, void displacement pieces) or significant impurities that may (possibly or inherently) be present in the package. Compliance with the specified quantity of fissile material is important as any change could produce a higher neutron multiplication factor owing to more fissile material or, in the case of less fissile material, could potentially allow a higher reactivity caused by altered optimal water moderation (e.g. the certificate may need to require complete fuel assemblies to be shipped intact with no pins removed). The inclusion of fissile material or other radionuclides not authorized for the package can have an unexpected effect on criticality safety (e.g. replacing U-235 by U-233 can yield a higher multiplication factor). Similarly, the placement of the same quantity of fissile material in a heterogeneous or homogeneous distribution can significantly affect the multiplication factor. A heterogeneous lattice arrangement provides a higher reactivity for low enriched uranium systems than a homogeneous distribution of the same quantity of material.

Uranium hexafluoride

420.1. The restrictions on the mass of uranium hexafluoride in a loaded package are specified in order to prevent overpressurization during both filling and emptying. The mass limit should be based upon the maximum uranium hexafluoride working temperature of the cylinder, the certified minimum internal volume of the cylinder, a minimum uranium hexafluoride purity of 99.5%, and a minimum safety margin of 5% free volume when the uranium hexafluoride is in the liquid state at the maximum working temperature [27]. Specifications for commercial uranium hexafluoride are given in Refs [28, 29]; these impose a minimum uranium hexafluoride purity of 99.5%.

420.2. The requirement that the uranium hexafluoride be in solid form and that the internal pressure inside the uranium hexafluoride cylinder be below atmospheric pressure when

presented for transport was established as a safe method of operation and to provide the maximum possible safety margin for transport. Generally, cylinders are filled with uranium hexafluoride at pressures above atmospheric pressure under gaseous or liquid conditions. Until the uranium hexafluoride is cooled and solidified, a failure of the containment system in either the cylinder or the associated plant fill system could result in a dangerous release of uranium hexafluoride. However, since the triple point of uranium hexafluoride is 64°C at normal atmospheric pressure of 1.013×10^5 Pa, if the uranium hexafluoride is presented for transport in a thermally steady state, solid condition, it is unlikely that during normal conditions of transport it will exceed the triple point temperature.

420.3. Satisfying the requirement that the uranium hexafluoride is in solid form with an internal cylinder pressure less than atmospheric pressure for transport ensures that:

- (a) The handling of the cylinder prior to, and following, transport and transport under normal conditions will occur with the greatest safety margin relative to the package performance.
- (b) The structural capabilities of the package are maximized.
- (c) The containment boundary of the package is functioning properly. Satisfying this requirement precludes cylinders that have not been properly cooled after the filling operation being presented for transport.

420.4. The criteria for establishing fill limits and the specific fill limits for the uranium hexafluoride cylinders most commonly used throughout the world are specified in Ref. [27]. Fill limits for any other uranium hexafluoride cylinder should be established using these criteria and, for any cylinder requiring competent authority approval, the analysis establishing the fill limit and the value of the fill limit should be included in the safety documentation submitted to the competent authority. A safe fill limit should accommodate the internal volume of the uranium hexafluoride when in heated liquid form and, in addition, an allowance for ullage (i.e. the gas volume) above the liquid in the container should be provided.

420.5. Uranium hexafluoride exhibits a significant expansion when undergoing the phase change from solid to liquid: it expands by 47% (from 0.19 cm³/g to 0.28 cm³/g) when changing from a solid at 20°C to a liquid at 64°C. In addition, liquid uranium hexafluoride will expand an additional 10% based on the solid volume (from 0.28 cm³/g at the triple point to 0.3 cm³/g) when heated from 64°C to 113°C). As a result, an additional substantial increase in volume of the uranium hexafluoride between the minimum fill temperature and higher temperatures can occur. Therefore, extreme care should be taken by the designer and the operator at the facility where uranium hexafluoride cylinders are filled to ensure that the safe fill limit for the cylinder is not exceeded. This is especially important since, if care is not taken, the quantity of material that can be added to a cylinder could greatly exceed the safe fill limit at the temperature where uranium hexafluoride is normally transferred into cylinders (e.g. at temperatures of about 71°C). For example, a 3964 L cylinder, with a fill limit of 12 261 kg could accept up to 14 257 kg of uranium hexafluoride at 71°C. When heated above 71°C, the liquid uranium hexafluoride would completely fill the cylinder and could hydraulically deform and rupture the cylinder. Quantities of uranium hexafluoride above 14 257 kg would rupture the cylinder if heated above 113°C. Hydraulic

rupture is a well understood phenomenon, and it should be prevented by adhering to established fill limits based on the cylinder certified minimum volume and a uranium hexafluoride density at 121°C for all cylinders or the maximum temperature relating to the design of the cylinder [30].

420.6. Prior to shipment of a uranium hexafluoride cylinder, the consignor should verify that its internal pressure is below atmospheric pressure by measurement with a pressure gauge or other suitable pressure indicating device. This is consistent with ISO 7195 [27], which indicates that a subatmospheric cold pressure test should be used to demonstrate suitability of the cylinder for transport of uranium hexafluoride. According to ISO 7195 [27], a cylinder of uranium hexafluoride should not be transported unless the internal pressure is demonstrated to be at a partial vacuum of 6.9×10^4 Pa. The operating procedure for the package should specify the maximum subatmospheric pressure allowed, measured in this fashion, which will be acceptable for shipment and the results of this measurement should be included in appropriate documentation. This prior to shipment test should also be accomplished subject to agreed management system procedures.

420.7. The reason for the introduction of UN 3507 in the Transport Regulations was to facilitate the shipments of small samples of uranium hexafluoride. It was not clear previously under which conditions of class 7 or class 8 shipments of these packages should be performed.

420.8. In the case of small quantities, typically sample shipments, of uranium hexafluoride, less than 0.1 kg, excepted packaging is permitted. The transport of such small quantities of uranium hexafluoride is required to be in accordance with para. 419(c) and the requirements of para. 420 of the Transport Regulations.

CLASSIFICATION OF PACKAGES

Classification as excepted package

422.1. The limits for contents of excepted packages are such that the hazard associated with a total release of radioactive material is consistent with the hazard from a Type A package releasing part of its contents (see Appendix I).

422.2. The basic activity limit for non-special form solid material that may be transported in an excepted package is $10^{-3}A_2$. This limit was derived on the basis of the assumption that 100% of the radioactive contents could be released from an excepted package in the event of an accident. The maximum activity of the release in such an event (i.e. $10^{-3}A_2$) is comparable with the fraction of the contents assumed to be released from a Type A package in the dosimetric models used for determining A_2 values (see Appendix I).

422.3. In the case of special form solid material, the probability of release of any dispersible radioactive material is very small. Thus, if radiotoxicity were the only hazard to be considered, much higher activity limits could be accepted for special form solid material in excepted packages. However, the nature of special form does not provide any additional protection from external radiation. The limits for excepted packages containing special form material are therefore based on A_1 rather than A_2 . The basic limit selected for special

form solid material is $10^{-3}A_1$. This limits the external dose rate from unshielded special form material to one thousandth of the rate used to determine the A_1 values.

422.4. For gaseous material, the arguments are similar to those for solid material and the basic excepted package limits for gaseous material are therefore also $10^{-3}A_2$ for non-special form and $10^{-3}A_1$ for special form material. It is to be noted that in the case of elemental gases the package limits are extremely pessimistic because the derivation of A_2 already embodies an assumption of 100% dispersal (see Appendix I).

422.5. Tritium gas has been listed separately because the actual A_2 value for tritium is much higher than 40 TBq, which is the generally applicable maximum for A_2 values. The value of $2 \times 10^{-2}A_2$ is conservative in comparison with other gases, even when allowing for conversion of tritium to tritiated water.

422.6. In the case of liquids, an additional safety factor of 10 has been applied because it was considered that there is a greater probability of a spill occurring in an accident. The basic excepted package limit for liquid material is therefore set at $10^{-4}A_2$.

422.7. Excepted packages cannot be classified as FISSILE. If the excepted package contains fissile material, the package is required to comply with one of the provisions in para. 417(a)–(f).

422.8. For shipments of less than 0.1 kg uranium hexafluoride, see also paras 420.7 and 420.8, and para. 618 of the Transport Regulations.

423.1. Limits other than the basic limits are allowed where the radioactive material is enclosed within, or forms a component part of, an instrument or other manufactured article where an added degree of protection is provided against escape of material in the event of an accident. The added degree of protection is assessed in most cases as a factor of 10, thus leading to limits for such items that are 10 times greater than the basic limits. The factor of 10 used in this and the other variations from the basic limits are pragmatically developed factors.

423.2. The added degree of protection is not available in the case of gases so that the item limits for instruments and manufactured articles containing gaseous sources remain the same as the limits for excepted packages containing gaseous material not enclosed in an instrument or article.

423.3. Packaging reduces both the probability of the contents being damaged and the likelihood of radioactive material in solid or liquid form escaping from the package. Accordingly, the excepted package limits for instruments and manufactured articles incorporating solid or liquid sources have been set at 100 times the item limits for individual instruments or articles.

423.4. With packages of instruments and articles containing gaseous sources, the packaging may still afford some protection against damage, but it will not significantly reduce the escape of any gases that may be released within it. The excepted package limits for instruments and articles incorporating gaseous sources have therefore been set at only 10 times the item limits for the individual instruments or articles.

423.5. Paragraph 423(b) allows for the exemption of the individual marking of each consumer product. In such a situation, marking 'Radioactive' on an internal surface of the package is required in such a manner that on opening the package, the identification of radioactive contents is readily and clearly visible.

424.1. See paras 422.2–422.6.

426.1. Articles manufactured from natural or depleted uranium may be classified as LSA-I and hence could be transported in an industrial package. However, provided the materials are contained in an inactive sheath made of metal or other substantial material they may be transported in excepted packages. The sheath is expected to prevent oxidation or abrasion, absorb all alpha radiation, reduce the beta dose rates and reduce the potential risk of contamination.

Additional requirements and controls for transport of empty packagings

427.1. The following examples describe potential alternative means for shipment where para. 427 is not applicable:

- (a) An empty packaging that cannot be securely closed owing to damage or other mechanical defects may be shipped by alternative means that are consistent with the requirements of the Transport Regulations, for instance, under special arrangement.
- (b) An empty packaging containing residual radioactive material or internal contamination in excess of 100 times the non-fixed contamination limits specified in para. 508 should only be shipped as a package category that is appropriate to the amount and form of the residual radioactivity or contamination.

427.2. Determining the residual internal activity within the interior of an empty packaging (see para. 427(c)) can be a difficult task. In addition to direct smears (wipes), various methods or combinations of methods that may be used include:

- (a) Gross activity measurement;
- (b) Direct measurement of radionuclides;
- (c) Material accountability, for example, by 'difference' calculations, from a knowledge of the activity or mass of the contents and the activity or mass removed in emptying the package.

Whichever method or combination of methods is used, care should be taken to prevent excessive and unnecessary exposure of personnel during the measuring process. Special attention should be paid to possible high dose rates when the containment system of an empty packaging is open.

427.3. 'Heels' of residual material tend to build up in uranium hexafluoride packagings upon emptying. These heels are generally not pure uranium hexafluoride but consist of materials (impurities) that do not sublime as readily as uranium hexafluoride (e.g. UO_2F_2 ,

uranium daughters, fission products and transuranic elements). Steps should be taken upon emptying to ensure that the package meets the requirements of para. 427 if it is being shipped as an empty packaging, and upon refilling to ensure that dose rates local to the heel are not excessively high, that the transport documents properly account for the heel and that the combined uranium hexafluoride contents and heel satisfy the appropriate material requirements. Appropriate assessment and cleaning upon either emptying or refilling may be necessary to satisfy the relevant regulatory requirements. For further information, see Refs [27, 30] and para. 546.5.

427.4. The purpose of labels is to provide information on the current package contents. Any previously displayed label could give the wrong information.

Classification as Type A packages

429.1. See para. 402.1.

430.1. The formula given in para. 430 can be used for mixtures of radionuclides and also for separate radionuclides contained in a single Type A package (see para. I.86).

Classification as Type B(U), B(M) or Type C packages

433.1. The $3000A_2$ limit for non-special form material was established taking into account the risk analysis work in Ref. [31] concerning Type B(U) package performance in air transport accidents. It is also the threshold quantity for which shipment approval of Type B(M) packages is required.

433.2. With regard to the contents limit for special form radioactive material, it follows from the Q system that $3000A_1$ was adopted for such material in parallel with the $3000A_2$ radioactive contents limit. However, for certain alpha emitters the ratio A_1 to A_2 can be as high as 10^4 , which would lead to potential package loadings that are equivalent to $3 \times 10^7 A_2$ not in dispersible form. This is undesirable, particularly if the special form radioactive material were partially disrupted in a very severe accident. The similarity between the special form impact test and the Type B(U) or Type B(M) package impact test implies that special form radioactive material may be expected to provide a 100 times lower release in comparison to a Type B(U) or Type B(M) package, allowing the contents limit to increase by a factor of 100 to $300\,000A_2$. The value of $10^5 A_2$ was adopted as a conservative estimate.

433.3. Radioactive material in a non-dispersible form or sealed in a strong metallic capsule presents a minimal contamination hazard, although the direct radiation hazard still exists. Studies have indicated that some special form radioactive materials approved under current standards retains its containment function following an air accident [31]. Consequently, additional protection provided by the definition of special form radioactive material is sufficient to ship special form radioactive material up to an activity of $3000A_1$ or up to $10^5 A_2$ by air in a Type B(U) or Type B(M) package.

REFERENCES TO SECTION IV

- [1] AMERSHAM INTERNATIONAL, communication with the National Radiological Protection Board provided inventory data of packages aboard conveyances (1986).
- [2] FINLEY, N.C., McCLURE, J.D., REARDON, P.C., WANGLER, M., “An analysis of the consequences of accidents involving shipments of multiple Type A radioactive material packages”, Packaging and Transportation of Radioactive Materials, PATRAM 89 (Proc. Int. Symp. Washington, DC, 1989), Oak Ridge Natl Lab., TN (1989).
- [3] GELDER, R., MAIRS, J.H., SHAW, K.B., “Radiological impact of transport accidents and incidents in the United Kingdom over a twenty year period”, Packaging and Transportation of Radioactive Materials, PATRAM 86 (Proc. Int. Symp. Davos, 1986), IAEA, Vienna (1987) 371–380.
- [4] MOHR, P.B., MOUNT, M.E., SCHWARTZ, M.E., “A highway accident involving radiopharmaceuticals near Brookhaven, Mississippi on December 3, 1983”, Rep. UCRL 53587 (NUREG/CR 4035), Nuclear Regulatory Commission, Washington, DC (1985).
- [5] EUROPEAN COMMISSION, FOOD AND AGRICULTURE ORGANIZATION OF THE UNITED NATIONS, INTERNATIONAL ATOMIC ENERGY AGENCY, INTERNATIONAL LABOUR ORGANIZATION, OECD NUCLEAR ENERGY AGENCY, PAN AMERICAN HEALTH ORGANIZATION, UNITED NATIONS ENVIRONMENT PROGRAMME, WORLD HEALTH ORGANIZATION Radiation Protection and Safety of Radiation Sources: International Basic Safety Standards, IAEA Safety Standards Series No. GSR Part 3, IAEA, Vienna (2014).
- [6] EUROPEAN COMMISSION, Principles and Methods For Establishing Concentrations (Exemption Values) Below which Reporting is Not Required in the European Directive, Radiation Protection Report No. 65, EC, Brussels (1993).
- [7] FRANCOIS, P., et al., “The application of exemption values to the transport of radioactive materials”, IRPA 9 (Proc. Ninth IRPA Int. Congr. Vienna, 1996), Vol. 4, IRPA, Vienna (1996) 674.
- [8] INTERNATIONAL ATOMIC ENERGY AGENCY, Interim Guidance for the Safe Transport of Reprocessed Uranium, IAEA-TECDOC-750, IAEA, Vienna (1994).
- [9] NITSCHKE, F., et al., “Review of the safety concept of LSA-II and LSA-III material requirements of the IAEA Transport Regulations SSR-6”, PATRAM 2016 (Proc. Int. Symp. Kobe, 2016), Japan Society of Mechanical Engineers, Tokyo, Japan (2016),

- [10] BECKER, D.L., BURGESS, D.M., LINDQUIST, M.R., “Shippingport reactor pressure vessel and neutron shield tank assembly probabilistic waterborne accident assessment”, Packaging and Transportation of Radioactive Materials, PATRAM 92 (Proc. Int. Symp. Yokohama, 1992), Science and Technology Agency, Tokyo (1992).
- [11] CLOSS, J.W, *ibid.*
- [12] POPE, R.B., et al., “Characterizing, for packaging and transport, large objects contaminated by radioactive material having a limited A₂ value”, Packaging and Transportation of Radioactive Materials, PATRAM 98 (Proc. Int. Symp. Paris, 1998), Institut de protection et de sûreté nucléaire, Paris (1998).
- [13] HILBERT, F., KUBEL, M., “Transport of two steam generators from the nuclear power station KWO to the interim storage site of EWN”, Packaging and Transportation of Radioactive Materials, PATRAM 2007 (Proc. Int. Symp. Miami, 2007), Intitute of Nuclear Materials Management, Deerfield, IL (2007).
- [14] DYBECK, P., BROMAN, U., *ibid.*
- [15] SVAHN, B., ZIKA, H., WELLEMAN, E., NILSSON, T., *ibid.*
- [16] NITSCHKE, F., FASTEN, C., “Transport of large components in Germany: Some experiences and regulatory aspects”, Packaging and Transport of Radioactive Materials, PATRAM 2010 (Proc. Int. Symp. London, 2010), Department for Transport, UK (2010).
- [17] KOMAN, S., DROSTE, B., WILLE, F., *ibid.*
- [18] SCHIFFER, W., HILBERT, F., *ibid.*
- [19] BOYLE, R.W., WILLIAMS, J.L., “Large component regulatory relief in the United States”, Packaging and Transportation of Radioactive Materials, PATRAM 2004 (Proc. Int. Symp. Berlin, 2004), Ramtrans Publishing, Ashford, UK (2004).
- [20] UNITED STATES DEPARTMENT OF ENERGY, Airborne Release Fractions/Rates and Respirable Fraction for Nonreactor Nuclear Facilities, DOE-HDBK-3010-94, USDOE, Washington, DC (1994).
- [21] GRAY, I., “Development of an improved radiological basis and revised requirements for the transport of LSA/SCO materials”, Packaging and Transportation of Radioactive Materials, PATRAM 2004 (Proc. Int. Symp. Berlin 2004), Ramtrans Publishing, Ashford, UK (2004).
- [22] INTERNATIONAL ATOMIC ENERGY AGENCY, Application of the Revised Provisions for Transport of Fissile Material in the IAEA Regulations for the Safe Transport of Radioactive Material – 2012 Edition, IAEA-TECDOC-1768, IAEA, Vienna (2015).

- [23] PAXTON, H.C., PRUVOST, N.L., Critical Dimensions of Systems Containing U-235, Pu-239 and U-233, Rep. LA-10860-MS, Los Alamos Natl Lab., NM (1987).
- [24] AMERICAN NUCLEAR SOCIETY, Nuclear Criticality Control and Safety of Plutonium–Uranium Fuel Mixtures Outside Reactors, Rep. ANSI/ANS-8.12-1987; R1993; R2002 (R = Reaffirmed) American Nuclear Society, La Grange Park, IL (2002).
- [25] LOS ALAMOS NATIONAL LABORATORY, The Nuclear Criticality Safety Guide, Rep. LA-12808, Los Alamos Natl Lab., NM (1996).
- [26] NUCLEAR REGULATORY COMMISSION, Exemption from Classification as Fissile Material, 10 CFR 71.15, US Government Printing Office, Washington, DC (2013).
- [27] INTERNATIONAL ORGANIZATION FOR STANDARDIZATION, Nuclear Energy — Packaging of Uranium Hexafluoride (UF₆) for Transport, ISO 7195:2005, ISO, Geneva (2005).
- [28] AMERICAN SOCIETY FOR TESTING AND MATERIALS, Standard Specification for Uranium Hexafluoride for Enrichment, ASTM-C787-15, ASTM, Philadelphia, PA (2015).
- [29] AMERICAN SOCIETY FOR TESTING AND MATERIALS, Standard Specification for Uranium Hexafluoride Enriched to Less than 5% ²³⁵U, ASTM-C996-15, ASTM, Philadelphia, PA (2015).
- [30] UNITED STATES ENRICHMENT CORPORATION, Reference USEC-651, USEC, Washington, DC (1998).
- [31] HUBERT, P., et al., Specification of Test Criteria and Probabilistic Approach: The Case of Plutonium Air Transport Probabilistic Safety Assessment and Risk Management, PSA 87, Verlag TÜV, Cologne (1987).

Section V

REQUIREMENTS AND CONTROLS FOR TRANSPORT

REQUIREMENTS BEFORE THE FIRST SHIPMENT

501.1. The consignor of a shipment of radioactive material should ensure that the packaging has been manufactured in compliance with the design specifications and the relevant certificate of approval (see para. 547 of the Transport Regulations on the consignor's required certification or declaration for shipment).

501.2. For ensuring safe transport of radioactive material, general requirements for a management system (para. 306) and compliance assurance (para. 307) have been established in the Transport Regulations. Specific inspection requirements to ensure compliance for those packaging features that have a major bearing on the integrity of the package and on radiation safety and criticality safety have also been established (see paras 501-503 of the Transport Regulations). These requirements cover inspections prior to the first shipment and prior to each subsequent shipment.

501.3. In the design phase of the package, documents should be prepared to define how the relevant requirements of the Transport Regulations are to be fully complied with for each manufactured packaging. Each document should be authorized (e.g. signed) by the persons directly responsible for each stage of manufacture. Inspection results of components (e.g. dimensions, material of construction, leak rates) should be recorded, even when they are within specified manufacturing tolerances. The completed documents should be retained on file, in conformance with the management system (see para. 306).

501.4. In the case of a containment system having a design pressure exceeding 35 kPa, it should be confirmed that the containment system in the 'as fabricated' state is sufficient. This may be accomplished, for instance, through testing. For packagings with fill and/or vent valves, these openings can be used to pressurize the containment system to its design pressure. If the containment system does not have such penetrations, the vessel and its closure may require separate testing using special fixtures. During these tests, seal integrity should be evaluated using the procedures established for normal use of the package.

501.5. In performing post-fabrication tests and inspections on packagings to assess the effectiveness of shielding of Type B(U), Type B(M), and Type C packages and packages containing fissile material, the shielding components may be checked by a radiation test of the completed assembly. The radiation source for this test need not be the material intended to be transported, but care should be taken such that shielding properties are properly evaluated relative to energy, energy spectrum, and type of radiation. Particular attention should also be paid to the homogeneity of packaging material and the possibility of increased localized dose rates at joints. For methods of testing the integrity of the radiation shielding of packages, see Refs [1, 2] and paras 659.16 and 659.17.

501.6. Containment integrity should be assessed using appropriate leakage rate tests (see paras 659.1–659.12 and 659.21–659.24).

501.7. Inspection of a packaging for heat transfer characteristics should include a dimensional check, with special attention paid to ventilation apertures, surface emissivity

and absorptivity and continuity of conduction paths. Proof tests, which may normally be necessary only for a prototype package, may be conducted by using electrical heaters in place of a radioactive source.

501.8. Packaging components significant for criticality safety need to be inspected and/or tested after fabrication and prior to the first shipment. Dimensional and material inspection of pertinent packaging components and welds should be completed to ensure the packaging components are fabricated and located as designed. Testing will most often involve assurance of the presence and distribution of the neutron poisons as discussed in para. 501.9.

501.9. In cases where criticality safety is dependent on the presence of neutron absorbers, it is preferable that the neutron absorber be a solid and an integral part of the packaging. Solutions of absorbers, or absorbers that are water soluble, are not endorsed for this purpose because their continued presence cannot be assured. The confirmation procedure or tests should ensure that the presence and distribution of the neutron absorber within the packaging components are consistent with that assumed in the criticality safety assessment. Merely ensuring the quantity of the neutron absorbing material is not always sufficient because the distribution of the neutron absorbers within a packaging component, or within the packaging contents themselves, can have a significant effect on the neutron multiplication factor for the system. Uncertainties in the confirmation technique should be considered in verifying consistency with the criticality safety assessment.

501.10. For further information see Refs [3–5].

REQUIREMENTS BEFORE EACH SHIPMENT

502.1. The consignor for a shipment of radioactive material should ensure that the package contents comply with the relevant requirements of the Transport Regulations and the relevant certificate of approval (see para. 547 on the consignor's required certification or declaration for shipment).

502.2. Before a packaging is to be used for material for which it was not designed, an additional assessment of the package design has to be performed and compliance for such material has to be confirmed and documented, and, where appropriate, competent authority approval obtained.

502.3. For spent fuel or radioactive waste, an exhaustive list of radionuclides is not always available. Nevertheless, the contents should comply with the assessed contents for the package design.

503.1. Before each shipment, the consignor should ensure that the package has been prepared for shipment in compliance with the relevant requirements of the Transport Regulations and the relevant certificate of approval (see also para. 547 on the consignor's required certification or declaration for shipment).

503.2. In addition to the requirements imposed by the Transport Regulations on certain packages prior to their first shipment (see para. 501) and prior to each shipment of any package (see paras 502 and 503), the consignor should ensure that only proper lifting

attachments are used during shipment and should verify that requirements for thermal and pressure stability have been complied with (see para. 503(b)).

503.3. Inspection and test procedures should be developed to ensure that the packaging requirements are satisfied. Compliance should be documented as part of the management system (see para. 306). When packages containing radioactive material have been stored for long periods, inspections should be carried out to verify compliance of the package with the relevant requirements of the Transport Regulations and the certificate of approval prior to shipment. These inspections could form part of a programme designed to monitor periodically the performance of a package during storage, which could be for several years to decades. Examples of inspections to be carried out before storage, during storage and before shipment after storage can be found in Ref. [6].

503.4. The package's certificate of approval is the evidence that the package design meets the regulatory requirements and that the package may be used for transport. The consignor has the responsibility to ensure that each individual package complies with the certificate of approval and the relevant requirements of the Transport Regulations. Checks to confirm compliance of the package with the applicable regulations and readiness for transport should be documented and authorized (e.g. signed) by the person directly responsible for this operation. Results of these checks (e.g. leak rates) should be recorded, even when they are within specified tolerances, and compared with the results of previous tests, so that any indication of deterioration may become apparent. The completed documents should be retained on file in conformance with the management system (see para. 306).

503.5. The approval certificates for packages containing fissile material indicate the authorized contents of the package (see paras 418 and 838). Prior to each shipment, the fissile material contents should be verified as having the characteristics provided in the listing of authorized contents. When removable neutron poisons or other removable criticality control features are specifically required by the certificate, inspections and/or tests, as appropriate, should be made to ascertain the presence, correct location(s) and/or concentrations of those neutron poisons or control features. Solutions of absorbers or absorbers that are water soluble are not endorsed for this purpose because their continued presence cannot be ensured. The confirmation procedure or tests should ensure that the presence, correct location(s) and/or concentration of the neutron absorber or control features within the package are consistent with those assumed in the criticality safety assessment. Merely verifying the quantity of the control material is not always sufficient because the distribution within the package can have a significant effect on the reactivity of the system.

503.6. Procedures should be developed and followed to ensure that steady state conditions have been reached by the loaded package by measuring the temperature and pressure over a defined period. In the performance of any test, it should be ensured that the method selected provides the required sensitivity and does not degrade the integrity of the package. Non-conformance with the approved design requirements should be fully documented and reported to the competent authority that approved the design.

503.7. Every Type B(U), Type B(M) and Type C package should be tested, after closure and before transport, to ensure compliance with the required leaktightness. Some national authorities may permit an assembly verification procedure followed by a less stringent

leakage test as offering equivalent confidence in meeting the design conditions. An example of an assembly verification procedure would be:

First, inspect and/or test comprehensively the complete containment system of an empty packaging. The radioactive contents may then be loaded into the packaging and only the closure components that were opened during loading need be inspected and/or tested as part of the assembly verification procedure.

In the case of packages where containment is provided by special form radioactive material, compliance may be demonstrated by possession of a certificate, prepared under the management system, which demonstrates the leaktightness of the source(s) concerned. The competent authority of the country concerned should be consulted if such a procedure is envisaged.

503.8. The leakage test requirements for Type B(U), Type B(M) and Type C packages, including the tests performed, frequency of testing and test sensitivity, are based on the maximum allowable leakage rates and standardized leakage rates calculated for the package for normal and accident conditions, as described in ISO 12807 [5]. Highly sensitive pre-shipment leakage testing may not be necessary for some Type B(U), Type B(M) or Type C packages depending, for example, on the material contained and the allowable leakage rate for this material. An example of such a material could be one that exceeds the specific activity limit for LSA-II material, but does not qualify as LSA-III. The physical characteristics of such a material might include a limited activity concentration and a physical form that reduces the dispersibility of the material. Packages carrying such a material may require pre-shipment leakage tests but the tests could be simple direct tests, such as gas and soap bubble qualitative tests or gas pressure drop and rise quantitative tests, as described in Refs [4, 5].

503.9. The measurement specified in para. 677(b) should verify that the irradiated nuclear fuel to be transported falls within the envelope of conditions demonstrated in the criticality safety assessment as satisfying the criteria in paras 673–685. Typically, the primary conditions proposed for use in the safety assessment of irradiated nuclear fuel of a known enrichment are the burnup and decay characteristics, and, as such, these are the parameters that should be verified by measurement. The measurement technique should depend on the likelihood of misloading the fuel and the amount of available subcritical margin due to irradiation. For example, as the number of fuel elements of varying irradiation states stored in the reactor pond and the length of time between discharge and shipment increase, so the likelihood of misloading increases. Similarly, if an irradiation of 10 GW·d/MTU is used in the criticality assessment, but fuel less than 40 GW·d/MTU is not permitted by the package design certificate to be loaded in the package, a measurement verification of irradiation using a technique with a large uncertainty may be adequate. However, if an irradiation of 35 GW·d/MTU is used in the criticality assessment, the measurement technique to verify irradiation should be much more reliable. The measurement criteria that should be met to allow the irradiated material to be loaded and/or shipped should be clearly specified in the certificate of approval. (See Ref. [7] for information on measurement approaches in use.)

503.10. The approval certificate should identify any requirements for closure of a package containing fissile material that are necessary as a result of the assumptions made in the criticality safety assessment in relation to water in-leakage for a single package in isolation

(see para. 680). Inspections and/or tests should be made to ascertain that all requirements for prevention of water in-leakage have been met.

TRANSPORT OF OTHER GOODS

505.1. The purpose of this requirement is to prevent radioactive contamination of other goods. (See paras 513.1–513.4 and 514.1.)

505.2 To be consistent with para. 508, the contamination limits should be applied when averaged over any area of 300 cm² of any part of the surface.

506.1. Dangerous goods may react if allowed to come into contact with one another. This could occur, for instance, as a result of leakage of a corrosive substance or of an accident causing an explosion. To minimize the possibility of packages containing radioactive material losing their containment integrity owing to the interaction of the package with other dangerous goods, they are required to be kept segregated from other dangerous cargo during transport or storage. The extent of this segregation is usually established by individual States or by the cognizant transport organizations (e.g. IMO, ICAO).

506.2. Information on specific storage, stowage and segregation requirements, as applicable, is contained in the regulatory documents of international transport organizations [8–15] and in provisions laid down in the regulatory documents of individual States. As these national regulations and provisions are frequently amended, the current editions should be consulted to ascertain the latest requirements.

OTHER DANGEROUS PROPERTIES OF CONTENTS

507.1. The Transport Regulations provide an acceptable level of control of the radiation and criticality hazards associated with the transport of radioactive material. With one exception (uranium hexafluoride, see para. 631), the Transport Regulations do not cover hazards that may be due to the physicochemical form in which radionuclides are transported. In some cases, such subsidiary hazards may exceed the radiological hazards. Compliance with the requirements of the Transport Regulations does not therefore absolve its users from the need to consider the other potentially dangerous properties of the contents.

507.2. The 1996 Edition of the Transport Regulations included, for the first time, provisions regarding the packaging requirements for uranium hexafluoride based on the chemical hazard as well as the radiological hazard and criticality hazard. Uranium hexafluoride is the only commodity for which a subsidiary hazard has been taken into account in the formulation of requirements in these Transport Regulations (see para. 631).

507.3. The United Nations Recommendations on the Transport of Dangerous Goods [16] classify all radioactive material in Class 7. In the case of radioactive material in excepted packages, the other dangerous properties may take precedence. The United Nations Recommendations prescribe performance tests for packagings for all dangerous goods and classify them as follows:

Class 1 — Explosives;

Class 2 — Gases;

Class 3 — Flammable liquids;

Class 4 — Flammable solids, substances liable to spontaneous combustion, substances which, on contact with water, emit flammable gases;

Class 5 — Oxidizing substances and organic peroxides;

Class 6 — Toxic and infectious substances;

Class 7 — Radioactive material;

Class 8 — Corrosive substances;

Class 9 — Miscellaneous dangerous substances and articles, including environmentally hazardous substances.

507.4. In addition to meeting the requirements of the Transport Regulations for their radioactive properties, radioactive consignments have to comply with the requirements specified by relevant international transport organizations and applicable provisions adopted by individual States for any other hazardous properties. This includes, for example, requirements on labelling and information to be provided in the transport documents, and may also include additional package design requirements and approvals by appropriate authorities.

507.5. Where the packaging requirements specified by relevant international standards organizations for a subsidiary hazard are more stringent than those stated in the Transport Regulations for the radiological hazard, the requirements for the subsidiary hazard will take precedence [16].

507.6. For radioactive material transported under pressure, or where internal pressure may develop during transport, or when the package is pressurized during filling or discharge, the package may be within the scope of pressure vessel codes of the Member States concerned.

507.7. Performance tests on packagings of goods with hazardous properties other than hazards due to radioactive and fissile properties are prescribed in the United Nations recommendations [16].

507.8. Additional labels denoting subsidiary hazards should be displayed as specified by the appropriate national and international transport regulations.

507.9. Since the regulations promulgated by the international transport organizations, as well as by individual Member States, are frequently amended, the current editions of the applicable regulations should be consulted to ascertain what additional provisions apply with respect to subsidiary hazards.

REQUIREMENTS AND CONTROLS FOR CONTAMINATION AND FOR LEAKING PACKAGES

508.1. The Transport Regulations prescribe limits for non-fixed contamination on the surfaces of packages and conveyances under routine conditions of transport (see para. 106). The limits for the surfaces of packages derive from a radiological model developed in Ref. [17] for the 1961 Edition of the Transport Regulations. In summary, the pathways of exposure considered in this model external beta irradiation of the skin, ingestion and the inhalation of resuspended material. Consideration was limited to the most hazardous radionuclides in common use, namely, Pu-239 and Ra-226 in the case of alpha emitters and Sr-90/Y-90 in the case of beta emitters. These derived limits correspond to values that were generally accepted for laboratory and plant working areas and were therefore conservative in the context of transport packages for which the exposure time and handling time for workers were expected to be very much less than for workers in laboratories or active plants. Since this derivation, although there have been changes in radiological protection parameters, the contamination limits have not been changed.

Following the contamination issue described in para. 309.1, a basic model was developed to evaluate annual doses to workers and to the public from the non-fixed surface contamination of packages [18].

One of the conclusions of Ref. [18] is that the contamination limits in para. 508 are conservative, especially for irradiated nuclear fuel package shipments. However, the decision was made to retain the existing conservative limits for non-fixed contamination on the external surface of any package.

508.2. In the case of packages contaminated with an alpha emitter, the exposure pathway that usually determines a derived limit for contamination is the inhalation of material that has been resuspended from the surfaces of packages. The value of a relevant resuspension factor (in Bq/cm³ per Bq/cm²) is subject to large uncertainties, but research in the field was reviewed in Ref. [19]. The wide range of reported values spans the value recommended for general use by the IAEA [20] of $5 \times 10^{-5}/\text{m}$, which assumes that only a fraction of the activity re-suspended may be in respirable form. In most cases, the level of non-fixed contamination is measured indirectly by wiping a known area with a filter paper or a wad of dry cotton wool or other material of a similar nature. It is common practice to assume that the activity on the wipe represents only 10% of the total non-fixed contamination present on the surface. The fraction on the wipe will include the activity most readily available for resuspension. The remaining activity on the surface represents contamination that is less easily resuspended. An appropriate value for the resuspension factor for application to the total amount of non-fixed contamination on transport packages is of the order of $10^{-5}/\text{m}$. For an annual exposure time of 1000 h in an atmosphere containing contamination resuspended from the surfaces of packages contaminated with Pu-239 at 0.4 Bq/cm² and using a resuspension factor of $10^{-5}/\text{m}$, the committed effective dose is about 2 mSv. In the case of contamination with Ra-226, the committed effective dose would be of the order of 0.1 mSv. For most beta-gamma emitters, exposure of the basal cells of the skin is the limiting exposure pathway. The 2007 ICRP Recommendations [21] recommend 7 mg/cm² as the nominal depth of the basal cells, but extend the range of depth to 2–10 mg/cm². A number of studies [22–24] provide dose rate conversion factors at a nominal depth of 7 mg/cm², or for the range 5–10 mg/cm². Skin contaminated by Sr-90/Y-90 at 4

Bq/cm² for 8 h per working day would give rise to an equivalent dose to the skin of about 20 mSv per year, to be compared with the annual limit of 500 mSv set out in GSR Part 3 [25]. This assumes a transfer factor of unity between package surfaces and skin.

508.3. In practice, contamination that appears fixed may become non-fixed as a result of the effects of, for instance, weather and/or handling. In most instances where small packages are slightly contaminated on the outer surfaces, the contamination is almost entirely removable or non-fixed, and the methods of measurement should reflect this. In some situations, however, such as in the case of fuel flasks that may have been immersed in contaminated cooling pond water whilst being loaded with irradiated fuel, this is not necessarily the case. Contaminants such as Cs-137 may strongly adhere to, or penetrate, steel surfaces. Contamination may become ingrained in pores, fine cracks and crevices, particularly in the vicinity of lid seals. Subsequent weathering, exposure to rain or even exposure to moist air conditions may cause some fixed contamination to be released or to become non-fixed. Care is necessary prior to dispatch to utilize appropriate decontamination methods to reduce the level of contamination such that the limits for non-fixed contamination would not be expected to be exceeded during the journey. It should be recognized that, on some occasions, the non-fixed contamination limits may be exceeded at the end of the journey. However, this situation generally presents no significant hazard because of the pessimistic and conservative assumptions used in calculating the derived limits for non-fixed contamination. In such situations, the consignee should inform the consignor so that the latter can determine the causes and minimize such occurrences in the future.

508.4. In all cases, contamination levels on the external surfaces of packages should be kept as low as is reasonably achievable. The most effective way to ensure this is to prevent the surfaces from becoming contaminated. Loading, unloading and handling methods should be kept under review to achieve this. In the particular case of fuel flasks mentioned above, the pond immersion time should be minimized and effective decontamination techniques should be devised. Seal areas should be cleared by high pressure sprays, wherever possible, and particular care should be taken to minimize the presence of contaminated water between the body and the lid of the flask. The use of a 'skirt' to eliminate contact with contaminated water in cooling ponds can prevent contamination of surfaces of the flask. If this is not possible, the use of strippable paints, pre-wetting with clean water and initiating decontamination as soon as possible may significantly reduce contamination. Particular attention should be given to removing contamination from joints and seal areas. Surface soiling should also be avoided wherever possible. Wiping a dirty surface both removes dirt and abrades the underlying substrate, especially if the latter is relatively soft, for example, paint or plastic. Thus, soiling can contribute to non-fixed contamination either by the loose dirt becoming contaminated itself or by wiping of the dirty surface generating loose contamination from the underlying substrate. Paints and plastics weather on exposure to sunlight. Amongst other effects, ultraviolet light oxidizes paint or plastic surfaces, thus increasing cation exchange capacity. This renders surfaces exposed to the environment increasingly susceptible to contamination by some soluble contaminants.

508.5. It should be kept in mind that, if all packages were contaminated close to the limits, the routine handling and storage of packages, for example in transit stores, airport terminals and rail marshalling yards, could lead to buildup of contamination in working areas. Checks should be made to ensure that any such buildup does not occur in areas where packages are

regularly handled. Similarly, it is advisable to check gloves or other items of clothing of personnel routinely handling packages.

508.6. The Transport Regulations set no specific limits for the levels of fixed contamination on packages, since the resulting external radiation therefrom will combine with the penetrating radiation from the contents, and the total dose rate from packages is controlled by other specific requirements. However, limits on fixed contamination are set for conveyances (see para. 513) to minimize the risk that it may become non-fixed as a result of, for instance, abrasion and weathering.

508.7. In a few cases, measurement of contamination may be made directly using contamination monitors. Such a measurement will include both fixed and non-fixed contamination. This will only be practicable where the level of background radiation from the installation in which the measurement is made or the dose rate from the contents of the package does not interfere. In most cases, the level of non-fixed contamination will have to be measured indirectly by wiping a known area with a smear and measuring the resultant activity transferred to the smear in an area not affected by radiation from other sources.

508.8. The derived limits for non-fixed contamination apply to the average level over an area of 300 cm² or to the total package if its total surface area is less than 300 cm². The level of non-fixed contamination may be determined by wiping an area of 300 cm² by hand with a filter paper, a wad of dry cotton wool or other material of a similar nature. The number of smear samples taken on a larger package should be such as to be representative of the whole surface and should be chosen to include areas known or expected to be more contaminated than the remainder of the surface. For routine surveys on a large package, such as an irradiated fuel flask, it is common practice to select a large number of fixed general positions to assist in identifying patterns and trends. Care should be taken that the identical position is not wiped on successive occasions since this would leave large areas unchecked and would tend to reduce the contamination levels in those areas that are checked.

508.9. The activity of the smear sample may be measured either with a portable contamination monitor or using a standard counting system. Care is necessary in converting the count rate to surface activity as a number of factors, such as counting efficiency, geometrical efficiency, counter calibration and the fraction of contamination removed from the surface to the smear sample, will affect the final result.

508.10. To avoid the underestimation of activity, the beta energy of the calibration source used for a counting system should not be greater than the beta energies of the contaminant being measured. The fraction of contamination removed by the wipe test can, in practice, vary over a wide range and is dependent on the nature of the surface, the nature of the contaminant, the pressure used in wiping, the contact area of the material used for the test, the technique of rubbing (e.g. missing parts of the 300 cm² area or doubly wiping them) and the accuracy to which the operator estimates the area to be 300 cm². It is common practice to assume that the fraction removed is 10%. This is usually viewed as being conservative (i.e. it results in overestimating the level of contamination). Other fractions may be used, but only if determined experimentally.

508.11. To apply para. 508, it is necessary to know the radioisotopic composition of surface contamination. (See Ref. [18].)

508.12. Users should develop specific contamination measurement techniques relevant to their particular circumstances. Such techniques include the use of smears and appropriate survey instruments. The instruments and detectors selected should take into account the likely radionuclides to be measured. Particular care should be taken in selecting instruments of appropriate energy dependence when low energy beta or alpha emitters are present. It should be recognized that the size of the smear and the size of the sensitive area of the detector are important factors in determining overall efficiency.

508.13. Operators should be adequately trained to ensure that the samples are obtained in a consistent manner. Comparison between operators may be valuable in this respect. Attention is drawn to the difficulties that occur if different organizations use techniques that are not fully compatible — especially in circumstances where it is not practical to maintain the levels of non-fixed contamination at near zero values.

509.1. See paras 508.1–508.13.

510.1. The prime purpose of inspection by a qualified person is to assess whether leakage of the radioactive contents or loss of shielding integrity has occurred or could be expected to occur, and either give assurance that the package is safe and meets the requirements of the Transport Regulations or, if this is not the case, assess the extent of the damage or leakage and the radiological implications. On rare occasions, it may be necessary to extend surveys and investigations back along the route, including the conveyances and the handling facilities, to identify and clean up any contaminated areas. Investigations may need to include the assessment of external dose and possible radioactive intake by transport workers and members of the public.

510.2. Vehicles containing damaged packages that appear to be leaking, or appear to be severely dented or breached, should be detained and secured until they have been declared safe by a qualified person.

513.1. Conveyances may become contaminated during the carriage of radioactive material by the non-fixed contamination on the packages. If the conveyance has become contaminated above the levels specified in para. 513, it should be decontaminated until the contamination is below these levels and as low as reasonably practicable (see para. 508). This requirement does not apply to the internal surfaces of a conveyance provided that the conveyance remains dedicated to the transport of radioactive material or SCOs under exclusive use (see para. 514.1).

513.2. Limits are also set on fixed contamination to minimize the risk in the event that it becomes non-fixed as a result of, for instance, abrasion and/or weathering.

513.3. If the non-fixed contamination on conveyances exceeds the limits in para. 508 of the Transport Regulations, the conveyance should be decontaminated and, following the decontamination, a measurement should be made of the fixed contamination. The dose rate resulting from the fixed contamination on the surfaces may be measured using a suitable

portable instrument held near to the surface of the conveyance. Such measurements should be made before the conveyance is loaded.

513.4. Where packages having relatively high levels of fixed contamination are handled regularly by the same transport workers, it may be necessary to consider not only the penetrating radiation but also the non-penetrating radiation from that contamination. The effective dose received by the workers from the penetrating radiation may be sufficiently low that no individual monitoring is necessary. If it is known that the fixed contamination levels may be high, then it may be prudent to derive a working limit to restrict the exposure of the workers' hands.

513.5. For measurement of surface dose rates, see paras 233.1–233.6.

514.1. While it is normally good practice to decontaminate a freight container or conveyance as quickly as possible so that it can be used for transporting other substances, there are situations, for example the transport of uranium or thorium ores, where conveyances are essentially dedicated to the transport of radioactive material, including unpackaged radioactive material, and are continually contaminated. In cases where the practice of using dedicated conveyances is common, an exception to the need to quickly decontaminate these conveyances or freight containers, as applicable, is provided for as long as these freight containers or conveyances remain in that dedicated use. Decontamination of the internal surfaces after every use could lead to unnecessary exposure of workers. On the other hand, the external surfaces that are continually being exposed to the environment, and that are generally much easier to decontaminate, should be decontaminated to below the applicable limits after each use.

514.2. When a freight container or conveyance is used to transport packages of radioactive material, the requirements of paras 509 and 513 apply in full in order to avoid contamination of packages by the internal surface contamination of the freight container or conveyance.

REQUIREMENTS AND CONTROLS FOR TRANSPORT OF EXCEPTED PACKAGES

515.1. Excepted packages are packages in which the radioactive contents are restricted to such low levels that the potential hazards are low enough not to require the stringent design provisions applicable to other types of package design. In addition to the requirements specific to excepted packages (see para. 515 of the Transport Regulations), other requirements are applicable depending on the contents of the excepted package. For example, an excepted package with fissile material has additional requirements as specified in para. 417(a)–(f).

516.1. The requirement that the dose rate at the surface of an excepted package does not exceed 5 $\mu\text{Sv/h}$ was established to ensure that sensitive photographic material will not be damaged and that any radiation dose to members of the public will be insignificant.

516.2. It is generally considered that radiation exposures not exceeding 0.15 mSv do not result in unacceptable fogging of undeveloped photographic film. A package containing such film would have to remain in contact with an excepted package having the maximum

dose rate on contact of 5 $\mu\text{Sv/h}$ for more than 20 h in order to receive a radiation dose above 0.1 mSv (see paras 562.12–562.14).

516.3. By the same argument, special segregation of excepted packages from persons is not necessary. Any radiation dose to members of the public will be insignificant, even if such a package is carried in the passenger compartment of a vehicle.

516.4. For measuring the dose rate, an appropriate instrument should be used (i.e. it should be sensitive to, and calibrated for, the type of radiation to be measured). In most cases, only penetrating radiation (gamma rays and neutrons) needs to be considered. For establishing the dose rate on the surface of a package, it is normally adequate to take the reading shown on the instrument when the instrument is held against the surface of the package. The instruments used should, wherever possible, be small compared with the size of the package. In view of the usually small dimension of excepted packages, instruments with a small detection chamber (Geiger–Müller tube, scintillation meter or ionization chamber) are most suited for the purpose. The instrument should be reliable, in good condition, properly maintained and calibrated.

516.5. The maximum dose rate should be determined taking into account potentially significant amplifying phenomena such as movement of the radioactive contents, or, in the case of packages containing liquids, change in the state of the contents, including segregation and/or precipitation of the radionuclides. These phenomena need to be taken into account by applying a correction factor to the maximum dose rate measured at the external surface of the package or by using a maximum value instead. This correction factor or maximum value should be provided in the package instructions for use. In any case, a dose rate measurement should be performed before shipment, and the maximum potential dose rate should be determined by taking into account any such factors.

REQUIREMENTS AND CONTROLS FOR TRANSPORT OF LSA MATERIAL AND SCOs IN INDUSTRIAL PACKAGES OR UNPACKAGED

517.1. The original definitions of LSA material and SCO in the Transport Regulations were such that, if packaging were lost, the contents could produce dose rates in excess of those deemed acceptable for Type A packages under accident conditions. Since industrial packages used for transporting LSA material and SCO are not required to withstand transport accidents, a provision was initiated in the 1985 Edition of the Transport Regulations to restrict package contents to the amount that would limit the external dose rate at 3 m from the unshielded material or object to 10 mSv/h. Geometrical changes of LSA material or SCO as a result of an accident are not expected to lead to a significant increase of this external dose rate. This limits the consequences of accidents associated with LSA material and SCO to essentially the same level as that associated with Type A packages, where the A_1 value is based on the unshielded contents of a Type A package creating dose rates of 100 mSv/h at a distance of 1 m.

517.2. In the case of solid radioactive waste essentially uniformly distributed in a concrete matrix placed inside a thick wall concrete packaging, this concrete wall is providing shielding; consequently, the requirements of para. 517 apply to the dose rate in the absence of this concrete wall. However, the dose rate at 3 m from the unshielded concrete matrix may be assessed by direct measurement outside the thick wall of the concrete packaging

and then corrected to take account of the shielding effect of the concrete wall. This method can also be used in the case of other types of packaging.

520.1. According to paras 413(a)(iii) and 520(c), SCO-I can have non-fixed contamination on inaccessible surfaces in excess of the values specified in para. 413(a)(i). Items such as pipes from the decommissioning of a facility are required to be prepared for unpackaged transport in such a way to ensure that there is no release of radioactive material into the conveyance. This can be done, for example, by using end caps or plugs at both ends of the pipes (see para. 413.7).

520.2. The basic concept of allowing transport of SCOs unpackaged is that, although unpackaged, the objects will most likely comply with the applicable Type IP package requirements, when the outer envelope (e.g. shell) is considered as packaging. In addition to being allowed to be transported unpackaged, certain requirements for Type IP packages may need to be excluded, provided that compensatory safety measures in the form of more stringent operational controls are demonstrated in order to ensure the same level of safety.

520.3. A written transport plan is required to be used to govern the transport of SCO-III. The transport plan should contain lines of authority, responsibilities, requirements, precautions, prerequisites, instructions, personnel restrictions, emergency response actions, a radiation protection programme that includes any conveyance transfers, and the sequence of events regarding the transport.

520.4. As part of the SCO-III transport plan, special attention should be paid to the radiation protection programme since the transport of the object as SCO-III would be conducted in a different manner from the routine transport of packages and may involve workers not familiar with transport of radioactive material. As such, it should take into account all steps and activities of transport and all relevant transport workers and members of the public. The dose rates from the object, the transport and handling methods — including, for each activity, the duration and distance of workers from the object — should be carefully reviewed and doses to workers and the public should be optimized.

520.5. The transport plan should also address the following points:

- (a) There is no explicit limit on the dose rate on the external surface (there is nevertheless a limit of 10 mSv/h at 3 m from the object and there is a limit of 2 mSv/h at the external surface of the vehicle). Therefore, due to the size of these objects and their slow movement compared to most packages, the transport plan should contain special precautions to ensure the protection of workers and the public, including during loading and unloading phases if applicable, and the control of access to the object.
- (b) There is no obligation to label a SCO-III. Therefore, the transport plan should contain provisions to ensure that the workers are informed of the dose rate in the vicinity of the object, so that they can take actions to help optimize their own exposures. The transport plan should also contain provisions for informing the public in accordance with the radiation protection programme.
- (c) Any supplementary requirements for loading, stowage, carriage, handling or unloading of the SCO-III.

520.6. For SCO-III, the free drop test requirement of para. 722 of the Transport Regulations should be applied to the SCO-III as prepared for transport, including parts permanently attached to the component, such as closures and shielding, without the benefit of any securing devices or systems.

520.7. If the conditions in the transport plan effectively prevent the SCO-III from dropping or colliding in certain orientations during transport, including handling, then these orientations could be ignored in assessing the maximum damage. Demonstration of compliance may be performed in accordance with any of the methods referred to in para. 701 of the Transport Regulations.

520.8. The SCO-III, including all sealed openings and crevices, as well as additional shielding, should be capable of withstanding the effects of any acceleration, vibration or vibration resonance that could arise under routine conditions of transport. This is to comply with para. 613 of the Transport Regulations under routine conditions of transport.

521.1. The higher the potential hazards of LSA material and SCO, the greater the integrity of the package should be. In assessing the potential hazards, the physical form of the LSA material has been taken into account in the Transport Regulations.

521.2. See para. 226.1.

522.1. The conveyance activity limits for LSA material and SCO take into account the greater hazards presented by liquids, gases, and combustible solids as well as possible contamination levels in the event of an accident.

522.2. 'Combustible solids' in Table 6 of the Transport Regulations means all LSA-II and LSA-III materials in solid form that are capable of sustaining combustion either on their own or in a fire.

522.3. For SCO-III, the pre-shipment safety assessment should demonstrate that the maximum intake of radioactive material for a person in the vicinity of an accident would be no more than that accepted for Type A packages (see Appendix VII).

522.4. For SCO-III, it is permitted to exceed the limit of 100 A₂ for a conveyance other than an inland waterway craft, or to exceed the limit of 10 A₂ for a hold or compartment of an inland waterway craft, provided that the transport plan contains precautions that are to be employed during transport to obtain an overall level of safety at least equivalent to that which would be provided if the limits had been applied.

- (a) For inland waterway craft, there is a risk of activity accumulation in the case of a sinking, as there are no strong currents in inland waterways nor are there any probable human activities near the waterways. The total activity limit per hold or compartment addresses this risk. The transport plan could include provisions such as:
- (i) Precautions on the craft to minimize the risk of sinking;
 - (ii) The designation of an organization capable of removing the SCO-III from the water in the event of sinking;
 - (iii) Specific features of the SCO-III that ensure that in the case of realistically long submersion, the activity release into the water would be minimized.

- (b) For conveyances other than inland waterway craft, there is a risk of activity accumulation in the event of an accident in confined space (e.g. in a tunnel). The total activity limit addresses this risk. The transport plan could include provisions such as:
- (i) Controls or features that minimize the risk of an accident;
 - (ii) Routing constraints to avoid confined spaces;
 - (iii) Specific features of the SCO-III that ensure that in the case of an accident in a confined space, the activity release into the air would be minimized.

DETERMINATION OF TRANSPORT INDEX (TI)

523.1. The TI is an indicator of the dose rate in the vicinity of a package, overpack, tank, freight container, conveyance, unpackaged LSA-I, unpackaged SCO-I or SCO-III and it is used in the provision of radiation protection measures during transport.

- (a) If the measured dose rate comprises more than one type of radiation, then the TI should be based on the sum of all the dose rates from each type of radiation.
- (b) The TI for loads of uranium and thorium ores and their concentrates can be determined without measuring the dose rates. Instead, the maximum dose rate at any point 1 m from the external surface of such loads may be taken as the level specified in para. 523(a). The multiplication factor of 100 (para. 523(a) and the additional multiplication factor for the largest cross-sectional area of the load (para. 523(b) and Table 7) are still required, when applicable, for determining the TI of such loads.

523.2. For the carriage of radioactive material in tanks, freight containers and unpackaged LSA-I material, SCO-I and SCO-III with a large cross-sectional area, where the contents cannot be reasonably treated as a point source, dose rates external to the loads do not decrease with distance as the inverse square law would indicate. Since the inverse square law formed the basis for the calculation of segregation distances, a mechanism was added for large dimension loads to compensate for the fact that dose rates at distances from the load greater than 1 m would be higher than the inverse square law would indicate. The requirement of para. 523(b), which in turn imposes the multiplication factors in Table 7, provides the mechanism to make the assigned TI correspond to dose rates at greater distances for those circumstances that warrant it. The factors approximate to those appropriate to treating the loads as broad plane sources or three-dimensional cylinders [26] rather than point sources, although actual radiation profiles are more complex owing to the influences of uneven self-shielding, source distribution and scatter. As the dose rate distribution around a package that provides enough shielding around its radioactive contents to comply with the TI limits (see para. 527 of the Transport Regulations) is rather similar to that obtained using a point source model, no multiplication factor needs to be applied to packages.

523.3.

523.3. The TI should be determined by scanning all the surfaces of a package, including the top and bottom, at a distance of 1 m. The highest value measured is the value that

determines the TI. Similarly, the TI for a tank, a freight container and unpackaged LSA-I and SCO-I materials is determined by measurement at 1 m from the surfaces, but a multiplication factor in accordance with the size of the load should be applied in order to define the TI. The size of the load will normally be taken as the maximum cross-sectional area of the tank, freight container or conveyance, but where its actual maximum area is known, this may be used, provided that it will not change during transport.

523.4. Where there are protrusions on the exterior surface, the protrusion should be ignored in determining the 1 m distance, except in the case of a finned package, in which case the measurement may be made at 1 m distance from the external envelope of the package.

523.5. The TI of a package should be determined on the basis of measured dose rates, considering the package in isolation.

523.6. The maximum dose rate should be determined taking into account potentially significant amplifying phenomena such as the movement of the radioactive contents, or, in the case of packages containing liquids, change in the state of the contents, including segregation and/or precipitation of the radionuclides. These phenomena need to be taken into account by applying a correction factor to the maximum dose rate measured at 1 m from the external surface of the package or by using a maximum value instead. This correction factor or maximum value should be provided in the package instructions for use. In any case, a dose rate measurement should be performed before shipment, and the maximum potential dose rate should be determined by taking into account any such factors.

524.1. For rigid overpacks, freight containers and conveyances, adding the TIs reflects a conservative approach as the sum of the TIs of the packages contained is expected to be higher than the TI obtained by measurement of the maximum dose rate at 1 m from the external surface of the overpack, freight container or conveyance owing to the effects of shielding and additional distance.

524A.1. In the case of non-rigid overpacks, the TI may only be determined as the sum of the TIs of all packages contained. This is necessary because the dimensions of the overpack are not fixed and dose rate measurements at different times may give rise to different results.

DETERMINATION OF CRITICALITY SAFETY INDEX FOR CONSIGNMENTS, FREIGHT CONTAINERS AND OVERPACKS

525.1. All packages containing fissile material, other than those excepted by para. 417, are assigned their appropriate CSI and should display the CSI value on the label, as shown in Fig. 5 of the Transport Regulations. The consignor should be careful to confirm that the CSI for each consignment is identical to the sum of the CSI values provided on the package labels.

LIMITS ON TRANSPORT INDEX, CRITICALITY SAFETY INDEX AND DOSE RATES FOR PACKAGES AND OVERPACKS

526.1. To comply with the general requirements for criticality control and radiation protection, limits are set for the maximum TI, the maximum CSI and the maximum external surface dose rate for packages and overpacks (see paras 527 and 528). In the case of

transport under exclusive use, these limits may be exceeded because of the additional operational controls (see paras 221.1–221.6).

527.1. The maximum dose rate should be determined taking into account potentially significant amplifying phenomena such as movement of the radioactive contents, or, in the case of packages containing liquids, change in the state of the contents, including segregation and/or precipitation of the radionuclides. These phenomena need to be taken into account by applying a correction factor to the maximum dose rate measured at the external surface of the package or by using a maximum value instead. This correction factor or maximum value should be provided in the package instructions for use. In any case, a dose rate measurement should be performed before shipment, and the maximum potential dose rate should be determined by taking into account any such factors. See also para. 526.1.

527.2. For uranium hexafluoride cylinders that have been emptied, the amount, location and isotopic composition of any remaining radioactive material is not precisely known. To demonstrate compliance with the requirement of para. 617, and based on a worst case scenario regarding the amount, location and isotopic composition of the remaining radioactive material (“maximum radioactive contents”, in accordance with para. 617, of the package design constituted by the cylinder and the remaining radioactive material, so called “heel”), a calculation can determine a conservative value for the period of time after cylinder emptying after which the dose rate around the package complies with the Transport Regulations. For a given shipment, i.e. real location and composition of the remaining radioactive material, an earlier shipment may be permitted based on an analysis of dose rate measurements from previous similar transports and by taking dose rate measurements at the time of consignment that demonstrate compliance with the Transport Regulations.

528.1. See para 527.1.

528.2. Even though a package or an overpack is permitted to have an external dose rate up to 10 mSv/h, the requirements for a maximum dose limit of 2 mSv/h on the surface of the conveyance or of 0.1 mSv/h at any point 2 m from the surface of the conveyance (see para. 573) may be more limiting in certain instances. See also para. 233.2 regarding the buildup of daughter nuclides in transport.

528.3. See para. 527.2

CATEGORIES

529.1. All packages, overpacks and freight containers, other than those consisting entirely of excepted packages, are required to be assigned a category. This is a prerequisite to labelling and vehicle placarding.

529.2. Packages, overpacks and freight containers, other than those consisting entirely of excepted packages, are required to be assigned to one of the categories I-WHITE, II-YELLOW or III-YELLOW to assist in handling and stowage. In certain cases, the package TI or surface dose rate may be in excess of what would normally be allowed for packages, overpacks or freight containers in the highest category (i.e. III-YELLOW). In such cases,

the Transport Regulations require that the consignment be transported under exclusive use conditions.

529.3. The dose rate limits inherent in the definition of the categories have been derived on the basis of assumed package and cargo handling procedures, exposure times for transport workers and exposure times for photographic film. These dose rate limits were derived as follows [27]:

- (a) Exposure rate of 0.005 mSv/h at surface: This surface limit was derived, not from consideration of effects of radiation on persons, but from the more limiting effect on undeveloped photographic film. Evaluation of the effect of radiation on sensitive X ray film in 1947 showed that threshold fogging would occur at an exposure of 0.15 mSv and a limit was set in the 1961 Edition of the Transport Regulations of 0.1 mSv linked to a nominal maximum exposure time of 24 h. In later editions of the Transport Regulations (1964, 1967, 1973 and 1973 (As Amended)), the 24 h period was rounded to 20 h and the limiting dose rate of 0.005 mSv/h was taken as a rounded-down value to provide protection to undeveloped film for such periods of transport. This dose rate was applied as a surface limit for category I-WHITE packages, which would ensure there being little likelihood of radiation damage to film or unacceptable doses to transport workers, without a need for segregation requirements.
- (b) Exposure rate of 0.1 mSv/h at 1 m: For the purposes of limiting the radiation dose to film and to persons, the dose of 0.1 mSv discussed in (a) above was combined with the exposure rate at 1 m from the package and an exposure time of 1 h to give the 10 times TI limitation of the 1964, 1967 and 1973 Editions of the Transport Regulations. This was based upon an assumed transit time of 24 h and the conventional separation distance of 4.5 m (15 feet) between parcels containing radium in use by the US Railway Express Company in 1947. The above limitation would yield a dose of approximately 0.1 mSv at 4.5 m in 24 h.
- (c) Exposure rate of 2 mSv/h at surface: A separate limit of 2 mSv/h at the surface was applied in addition to the limit explained in (b) above on the basis that a transport worker carrying such packages for 30 min per day, held close to the body, would not exceed the then permissible dose of 1 mSv per 8 h working day. While such doses would no longer be acceptable, the adequacy of the current dose rate limits, in terms of radiological safety, has been confirmed by a number of surveys where the radiation exposure of transport workers has been determined [28–31] and by an assessment performed by the IAEA in 1985 [32].

It is recognized that the permitted dose rates around packages and conveyances do not alone ensure acceptably low doses; consequently, the Transport Regulations also require the establishment of RPPs (para. 302) and the periodic assessment of radiation doses to persons due to the transport of radioactive material (para. 308).

529.4. The category of a package should be determined on the basis of measured dose rates, considering the package in isolation.

529.5 A conveyance carrying large freight containers that are under exclusive use does not itself need to be under exclusive use, provided that access into the large freight container is under the strict control of the consignor or consignee.

MARKING, LABELLING AND PLACARDING

530.1. The implementation of the 1996 Edition of the Transport Regulations could lead to multiple labelling and marking because of the divergence between approvals issued by different competent authorities. Known cases are Type B(U) versus Type B(M); approved package design versus special arrangement; and Type A, fissile versus Type IP, fissile. To avoid having to change the marking and labelling at border crossings, only one United Nations number (UN number), determined in accordance with para. 530, should be applied.

Marking

531.1. To retain the possibility of identifying the consignee or consignor of a package for which normal control is lost (e.g. lost in transit or misplaced), an identification marking is required on the outside of the packaging. This marking may consist of the name or address of either the consignor or consignee, or it may be a number identifying a way-bill or transport document that contains this information. Each overpack is also required to be so marked unless the markings on all the inner packages are clearly visible within the overpack.

531.2. See paras 533.2–533.6 for general advice on compliance with the requirement for the marking to be legible and durable.

532.1. The UN number marked on the package and indicated in the documents provides important information in the event of incidents and accidents. The UN number corresponding to the approval certificate issued by the competent authority of the country of origin of design gives the information about package type that is needed for emergency management.

532.2. UN numbers for radioactive material are also used to relate requirements in the Schedules to the Transport Regulations. This has proved to be an advantage in terms of identifying the applicable requirements to specific package or material types. UN numbers can also be used for compliance situations, performance checks and controls, data collection and other statistical purposes should the competent authority find merit in this application.

532.3. UN numbers 2977 and 2978 should be used instead of LSA material shipping numbers to help the emergency response team to address the specific hazards raised by uranium hexafluoride in the event of an accident involving a severe fire, i.e. which raises more severe hazards than a fire on other LSA material [33]. It is also considered that when an accident occurs involving uranium hexafluoride transported under special arrangement, it is better that the emergency response teams are quickly informed that uranium hexafluoride is involved in the accident.

532.4. See paras 533.2–533.6 for general advice on compliance with the requirement for the marking to be legible and durable.

533.1. Packages exceeding 50 kg gross mass are likely to be handled by mechanical rather than manual means and require marking of the gross mass to indicate the possible need for mechanical handling and observance of floor loading and vehicle loading limits. In practice, however, even packages having a gross mass of up to 50 kg should not regularly be handled manually. Before packages are handled manually on a regular basis, a procedure should be available to ensure that the radiological consequences are as low as reasonably achievable (see para. 302). Mechanical means should be used wherever practicable. To be useful in this respect, the marking is required to be legible and durable.

533.2. Markings on packages should be boldly printed, of sufficient size and sensibly located to be legible, bearing in mind the likely handling means to be employed. A character height of 12.5 mm should be considered a suitable minimum for lightweight packages (i.e. up to a few hundred kilograms) where close contact by mechanical means, for example forklift trucks, is likely to be used. Heavier packages will require more 'remote' handling methods, and the character size should be increased accordingly to allow operators to read the markings at a distance. A size of 65 mm is considered to be sufficient for the largest packages in the tens of tonnes to the hundred tonne range. To ensure legibility, a contrasting background should be applied before marking if the external finish of the package does not already provide a sufficient contrast. Black characters on a white background are suitable. Where packages have irregular outer surfaces (e.g. fins or corrugations) or surfaces unsuitable for direct application of the markings, it may be necessary to provide a flat board or plate on which to place the markings to enhance legibility.

533.3. Markings should be durable in the sense of being at least resistant to the rigours of normal transport, including the effects of weather exposure and abrasion, without substantial reduction in legibility. Attention is drawn to the need to consult national and modal transport regulations, which may contain stricter requirements. For example, the IMDG Code [8] requires all permanent markings (and labels) to remain identifiable on packages surviving immersion in the sea for at least three months. When a board or plate is used to bear a marking, it should be fitted securely to the package in a manner consistent with the integrity standard of the package itself.

533.4. The means of marking will depend on the nature of the external surface of the packaging itself, ranging (in order of durability) from a printed label (e.g. for the name of the consignee or consignor, UN number and proper shipping name, and the gross mass), stencilling or soft stamping with indelible inks or paints (suitable for fibreboard or wooden packagings), through branding (for wooden packagings), painting with enamel or resin based paints (suitable for many surfaces, particularly metals), to hard stamping, embossing or 'cast-in' markings of metallic outer packagings.

533.5. Appropriate national and modal transport regulations should always be consulted to supplement the general advice in paras 533.2–533.4, as variations in the detailed requirements may be considerable.

533.6. The scheduled inspection and maintenance programme required for packagings should include provisions to inspect all permanent markings and to repair any damage or defects. Experience from such inspections will indicate whether durability has been achieved in practice.

534.1. The 1996 Edition of the Transport Regulations introduces the requirement to identify industrial packages with a mark. The design of the mark is consistent with other similar marks in that it includes the word 'Type' together with the appropriate industrial package description (e.g. Type IP-2). The design of the mark also avoids potential confusion where, in other transport regulations, the abbreviation 'IP' may be used for a different purpose. For example, the ICAO Technical Instructions [12] use IP to denote inner packaging. For example, 'IP.3' denotes one out of ten particular kinds of inner packagings.

534.2. See paras 533.2–533.6 for general advice on compliance with the requirement for the marking to be legible and durable.

535.1. All Type B(U), Type B(M), Type C and fissile material package designs require competent authority approval. Markings on such packages provide a link between the individual package and the corresponding national competent authority design approval (via the identification mark), as well as information on the kind of competent authority design approval. Furthermore, the marking of the package provides, to the knowledgeable observer, valuable information in the event of an accident.

535.2. The marking with a serial number is required because operational management system activities and maintenance activities are oriented towards each packaging and the corresponding need to perform and verify these activities on an individual packaging basis. The serial number is also necessary for the competent authority's compliance assurance activities and for application of paras 819 and 820.

535.3. General advice on legibility, durability of markings and inspection and maintenance of markings is given in paras 533.2–533.6. However, wherever possible, the competent authority identification mark, serial number and Type B(U), Type B(M) or Type C mark should be resistant to being rendered illegible, obliterated or removed, even under accident conditions. It may be convenient to apply such markings adjacent to the trefoil symbol on the external surface of the package. For example, an embossed metal plate may be used to combine these markings.

535.4. An approved package design may be such that different internal components can be used with a single outermost component, or the internal components of the packaging may be interchangeable between more than one outermost component. In these cases, each outermost component of the packaging with a unique serial number will identify the packaging as an assembly of components that satisfies the requirements of para. 535(b), provided that the assembly of components is in accordance with the design approved by the competent authorities. In such cases, the management system established by the consignor should ensure the correct identification and use of these components.

536.1. The marking of a Type B(U), Type B(M) or Type C package with a trefoil symbol resistant to the effects of fire and water is intended to ensure that such a type of package can be positively identified as carrying radioactive material even after a severe accident.

536A.1 In some cases, the marking of the package type might not be consistent with the UN number displayed on the package because the UN number has been changed based on the

contents of the package. In the event of incidents during transport, such inconsistency can be confusing for the first responders. Therefore, any mark not related to the UN number should be removed or covered.

537.1. LSA-I material and SCO-I may be transported unpackaged under the conditions given in para. 520. One of these conditions is intended to ensure that there will be no loss of contents during routine conditions of transport. Depending on the characteristics of the material, wrapping or similar measures may be suitable to satisfy this requirement. Wrapping may also be advantageous from a practical point of view, for example, to be able to affix a label containing information of interest to the consignee or consignor. In situations where it is desirable to clearly identify the consignment as carrying radioactive material, the Transport Regulations explicitly allow such an identifier to be placed on the wrapping or receptacle. It is important to note that the Transport Regulations do not require such marking; the option is, however, made available for application where it is considered useful.

Labelling

538.1. Transport workers need to be made aware when packages, overpacks, tanks and freight containers contain radioactive material and need to know that potential radiological and criticality hazards exist. The labels provide this information by the trefoil symbol, the colour and the category (I-WHITE, II-YELLOW or III-YELLOW), and the fissile label. Through the labels, it is possible to identify (a) the radiological or criticality hazards associated with the radioactive contents, and (b) the storage and stowage provisions that are applicable to the package, overpack, tank or freight container.

538.2. The labels used for radioactive material form part of a set of labels used internationally to identify the various classes of dangerous goods. This set of labels has been established with the aim of making dangerous goods easily recognizable from a distance by means of symbols. The specific symbol chosen to identify packages, overpacks, tanks and freight containers carrying radioactive material is the trefoil (see para. 536 and Fig. 1 of the Transport Regulations).

538.3. The content of a package, overpack, tank or freight container, in addition to its radioactive properties, might also be dangerous in other respects, for example, corrosive or flammable. In these cases, the regulations pertaining to this additional hazard have to be complied with. This means that, in addition to the radioactive material label, other relevant labels need to be displayed on the package, overpack, tank or freight container.

539.1. For tanks or freight containers, because of the chance that the container could be obscured by other freight containers and tanks, the labels need to be displayed on all four sides in order to ensure that a label is visible without having to be searched for, and to minimize the chance of its being obscured by other cargo. For an open-sided freight container, labels should be affixed to the side of the platform or corner post, or to any other suitable surface, on which the labels are clearly visible.

Labelling for radioactive contents

540.1. In addition to identifying the radioactive nature of the contents, the labels also carry more specific information regarding the contents (i.e. the name of the nuclide, or the most restrictive nuclides in the case of a mixture of radionuclides, and the activity). In the case of fissile contents, the total mass of fissile nuclides in units of grams, or multiples thereof, may be used in place of activity. This information is important in the event of an incident or accident where information on the contents may be needed to evaluate the hazard. The more specific information regarding the contents is not required for LSA-I material, because of the low radiation hazard associated with such material.

540.2. Yellow labels also show the TI of the package, overpack, tank or freight container. The TI information is essential in terms of storage and stowage in that it is used to control accumulation and segregation of cargo. The Transport Regulations prescribe limits on the total sum of TIs in freight containers and conveyances not under exclusive use (see Table 10 of the Transport Regulations).

540.3. In the identification of the most restrictive radionuclides for the purpose of identifying a mixture of radionuclides as the contents on a label, consideration should be given not only to the lowest A_1 or A_2 values, but also to the relative quantities of radionuclides involved. For example, a way to identify the most restrictive radionuclide is by determining, for the various radionuclides, the value of:

$$f_i/A_i$$

where

f_i is the activity of radionuclide i ;

A_i is the A_1 or A_2 value for radionuclide i , as applicable.

The highest value represents the most restrictive radionuclide.

Labelling for criticality safety

541.1. The CSI is a value used for controlling the accumulation of packages for criticality safety purposes, as required in paras 568 and 569. The control is provided by limiting the sum of the CSIs to the values listed in Table 11 of the Transport Regulations.

541.2. The labels carrying the CSI should appear on packages containing fissile material, as required by para. 538. The CSI label is additional to the category labels (categories I-WHITE, II-YELLOW and III-YELLOW), because its purpose is to provide information on the CSI, whereas the category label provides information on the TI and the contents. The CSI label also identifies the package as containing fissile material.

541.3. As with the TI, the CSI provides essential information relevant to storage and stowage arrangements in that it is used to control the accumulation and ensure proper separation of cargo containing fissile material. The Transport Regulations prescribe limits on the total sum of CSIs in freight containers and conveyances (See Table 11 of the Transport Regulations).

542.1. See paras 541.1– 541.3.

Placarding

543.1. Placards, which are used on large freight containers and tanks (and on road and rail vehicles (see para. 571)), are designed in a similar way to the package labels (although they do not bear the detailed information of TI, contents and activity) in order to identify clearly the hazards of the dangerous goods. Displaying the placards on all four sides of the freight containers and tanks ensures ready recognition from all directions. The size of the placard is intended to make it easy to read, even at a distance. To prevent the need for an excessive number of placards and labels, an enlarged label may only be used on large freight containers and tanks where it also serves the function of a placard.

543.2 For an open-sided freight container, placards should be affixed to the side of the platform or corner post, or to any other suitable surface, on which the placards are clearly visible.

544.1. The display of the UN number can provide information on the type of the radioactive material transported, including whether or not it is fissile, and information on the package type. This information is important in the case of incidents or accidents resulting in leakage of the radioactive material in that it assists those responsible for emergency response to determine the proper response actions (see para. 401.1).

CONSIGNOR'S RESPONSIBILITIES

545.1. The consignor should take appropriate actions in accordance with its management system to ensure that compliance with the requirements of the Transport Regulations can be demonstrated. This does not mean that actions such as placarding the vehicle have to be carried out by the consignor itself.

Particulars of consignment

546.1. The list of information provided by the consignor in complying with para. 546 is intended to inform the carrier and the consignee, as well as other parties concerned, of the exact nature of a consignment so that appropriate actions may be taken. In providing this information, the consignor is also reminded of the regulatory requirements applicable to the consignment throughout its preparation for transport and dispatch (see para. 532.1).

546.2. A list of the proper shipping names and the corresponding UN numbers is provided in Table 1 of the Transport Regulations.

546.3. The attention of the consignor is drawn to the requirement of para. 546(k) regarding consignments of packages in an overpack, freight container or conveyance. Each package or collection of packages is required to have documents for the appropriate consignee. This is important with regard to the consignor's declaration. No one other than the consignor can make this declaration and so he or she is required to ensure that appropriate documents are prepared for all parts of a mixed consignment so that they can continue their journey after being removed from an overpack, freight container or conveyance.

546.4. Care should be exercised in selecting the proper shipping name from Table 1 of the Transport Regulations. Portions of an entry that are not written in capital (i.e. uppercase) letters are not considered part of the proper shipping name. When the proper shipping name

contains the conjunction ‘or’, then only one of the possible alternatives should be used. The following examples illustrate the selection of proper shipping names of the entry for UN numbers 2909, 2915 and 3332:

For UN No. 2909 RADIOACTIVE MATERIAL, EXCEPTED PACKAGE — ARTICLES MANUFACTURED FROM NATURAL URANIUM or DEPLETED URANIUM or NATURAL THORIUM, the proper shipping name is the applicable description from the following:

UN No. 2909 RADIOACTIVE MATERIAL, EXCEPTED PACKAGE — ARTICLES MANUFACTURED FROM NATURAL URANIUM;

UN No. 2909 RADIOACTIVE MATERIAL, EXCEPTED PACKAGE — ARTICLES MANUFACTURED FROM DEPLETED URANIUM;

UN No. 2909 RADIOACTIVE MATERIAL, EXCEPTED PACKAGE — ARTICLES MANUFACTURED FROM NATURAL THORIUM.

For, UN No. 2915 RADIOACTIVE MATERIAL, TYPE A PACKAGE, non-special form, non-fissile or fissile-excepted, the proper shipping name is:

UN No. 2915 RADIOACTIVE MATERIAL, TYPE A PACKAGE

For UN No. 3332 RADIOACTIVE MATERIAL, TYPE A PACKAGE, SPECIAL FORM, non-fissile or fissile-excepted, the proper shipping name is:

UN No. 3332 RADIOACTIVE MATERIAL, TYPE A PACKAGE, SPECIAL FORM.

As can be seen from the example of UN No. 3332, the added characteristic (in this case, “SPECIAL FORM”) is part of the proper shipping name, and the lowercase words “non-fissile or fissile-excepted” are not part of the proper shipping name.

546.5. Another example related to the interpretation and use of the UN number concept relates to empty packagings that previously contained radioactive material (i.e. UN No. 2908). If there are residues or heels in the packaging, for example, in uranium hexafluoride packages, the packaging should not be called an ‘empty packaging’ but should be shipped as a package (i.e. not as a packaging). The quantity remaining would determine the package category (see para. 427.3).

546.6. The maximum activity of the contents during transport is required to be specified in the transport documents (para. 546(g)). In some cases, the activity may increase as a result of the buildup of daughter nuclides during transport. In such cases, a proper correction should be applied to determine the maximum activity.

546.7. Advice on the identification of the most restrictive nuclides is given in para. 540.3. Appropriate general descriptions may include, when relevant, irradiated (or spent) nuclear fuel or specified types of radioactive waste.

546.8. It is necessary for LSA-II and LSA-III materials and for SCO-I and SCO-II to indicate the total activity as a multiple of A_2 . For SCO-I and SCO-II, the activity should be calculated from the surface contamination level and the size of the contaminated surface area. In the case that the nuclide cannot be identified, the lowest A_2 value among the possible alpha nuclides and the beta–gamma nuclides should be used for the calculation of the total activity.

Information for carriers

554.1. With regard to the loading, stowage, carriage, handling and unloading of SCO-III, see para 520.4.

Possession of certificates and instructions

561.1. As well as having a copy of the package approval certificate, the consignor is required to ensure that it has the necessary instructions for properly closing and preparing the package for transport. In some countries, it may be necessary for the consignor to register as a user of that certificate with the appropriate competent authority.

TRANSPORT AND STORAGE IN TRANSIT

Segregation during transport and storage in transit

562.1. Operational controls that are applied in the transport of radioactive material can include the use of segregation distances. Segregation distances are usually tabulated as a function of the total TI, along with some time dependence. These tables are generally derived at a global or national level (e.g., the ICAO Technical Instructions [12]) and include the effects of the operations of many consignors, shippers and carriers on either the most exposed worker or a representative person of the public.

562.2. In terms of the history of the parameters used in the derivation of segregation tables, originally a fraction of the dose limit was chosen in each case (for workers and for members of the public) and what was considered to be a realistic model was used to derive the segregation distances for each mode of transport. With the production of more realistic data [34–36], it has become apparent that the models used are very conservative. As a result, as the dose limits have been reduced, the models and dose criteria have been shown to continue to provide adequate segregation [37]. By comparing all aspects of the practice (not simply segregation) with appropriate dose constraints for transport (as a whole — not just for one transport operation), the use of the current tables has been deemed as providing an adequate level of safety.

562.3. A review was carried out during the preparation of the 1996 Edition of the Transport Regulations. The model and dose criteria used to establish segregation distances were examined considering the developing philosophy of dose constraints, as discussed in Ref. [38] (the methodology of which is used in Ref. [39]). A dose constraint of 0.7 mSv was considered appropriate for exposure of a critical group of the public to direct radiation from

practices such as transport of radioactive material. This constraint was envisaged as being applicable to global transport operations in general rather than the operations of one particular consignor. Over a series of three technical meetings, information on assessed exposures to members of the public was actively collected and evaluated. This demonstrated that the exposures being received by members of the public from these operations were far below the dose criterion used in the modelling and also below the appropriate dose constraint [36]. The conclusion of these studies was that the existing segregation tables, together with the other requirements of the Transport Regulations, provide for an appropriate level of radiation safety and are consistent with the use of appropriate dose constraints.

562.4. The use of segregation distances does not in itself remove the need for establishing a radiation protection programme and implementing the measures to be employed in the programme, nor does it guarantee appropriate optimization for the transport of radioactive material.

562.5. The dose criteria of 5 mSv in a year for occupationally exposed workers and of 1 mSv in a year for members of the public (see para. 562(a) and 562(b) in the Transport Regulations) have been used to calculate segregation tables applicable to overall transport operations (i.e. they include the activities of all transport practices). In some cases, it may be appropriate for consignors and/or carriers to develop segregation tables applicable to individual shipments or transport campaigns. For those calculations, the characteristics should be well defined and therefore the model may be more realistic. In these cases, the associated dose criteria for public exposure will need to be revised downward significantly (this may also be the case for workers) to take into account the possibility of exposure to other transport operations (or other sources of exposure of workers).

562.6. There are many considerations and conditions specific to the transport mode that should be factored into the models used to calculate segregation distances. These include consideration of how the relationship between accumulated TIs in a location and dose rates in occupied areas is affected by shielding and distance, and how exposure times for workers and members of the public depend upon the frequency and duration of their travel in conjunction with radioactive material. These may be established by using questionnaires, surveys and measurements. In some circumstances, exposure for a short time close to packages, for example, during inspection or maintenance work on sea voyages, can be more important than longer exposure times at lower dose rates in more regularly occupied areas. An example of the use of a model for determining minimum segregation and spacing distances for passenger and cargo aircraft is given in Appendix III.

562.7. Inevitably, such calculations will be based on assumptions that may differ from real parameters in particular circumstances. Models should be robust and conservative. That the application of the resulting segregation distances leads to acceptably low doses is more important than the basis on which the distances were calculated. However, transport patterns are subject to change and doses should be kept under review.

562.8. The virtues of simplicity should not be ignored. Clear and simple requirements are more easily, and more likely, to be followed than complex, more rigorous ones. The simplified segregation table in the IMDG Code [8] giving practical segregation distances

for different types of vessel and the translation of the segregation distances of the ICAO Technical Instructions [12] by operators into TI limits per hold are good examples of this.

562.9. When calculating segregation distances for storage in transit areas, the TI of the packages and the maximum time of occupancy should be considered. If there is any doubt regarding the effectiveness of the distance, a check may be made by measuring the actual dose rates.

562.10. If different classes of dangerous goods are being transported together, there is a possibility that the contents of leaking packages may affect adjacent cargo, for example, leakage of corrosive material could reduce the effectiveness of the containment system for a package of radioactive material. Thus, in some cases, it has been found necessary to restrict the classes of dangerous goods that may be transported near other classes. In some cases, it may simply be stated which classes of dangerous goods need to be segregated from others. To provide a complete and simple procedure for understanding the necessary segregation, it has been found that presentation of this information in a concise tabular form is useful. As an example, the segregation table from Part 7 of the IMDG Code [8] is reproduced here as Table 2.

562.11. Although not a radiation protection issue, an evaluation of the effect of radiation exposure on fast X ray films in 1947 [42] determined that they may show slight fogging after development when exposed to doses exceeding 0.15 mSv of gamma radiation. This could interfere with the proper use of the film and provide incorrect diagnostic interpretation. Other types of film are also susceptible to fogging, although the doses required are much higher. Since it would be impracticable to introduce segregation procedures that vary with the type of film, the requirements of the Transport Regulations are designed to restrict the exposure of undeveloped film of all kinds to not more than 0.1 mSv during any journey from consignor to consignee.

562.12. The different time durations involved for maritime transport (in terms of days or weeks) and air or land transport (in terms of hours or days) mean that different tables of segregation distances are used, so that the total film exposure during transit is the same for each mode. More than one mode of transport and more than one shipment may be involved in the distribution and use of photographic film. Thus, when segregation distance tables are being established for a specific transport mode, only a fraction of the limit prescribed in para. 562 should be assigned to that mode. In road transport, a driver may ensure sufficient segregation from photographic film carried in other vehicles by leaving a clear space of at least 2 m all around the vehicle when parking.

562.13. Since mail bags often contain undeveloped film and will not be identified as such, it is prudent to protect them in the same way as identified undeveloped film.

Stowage during transport and storage in transit

564.1. Within the context of the Transport Regulations, 'stowage' means the locating within or on a conveyance of a package containing radioactive material relative to other cargo (both radioactive and non-radioactive). In relation to the stowage of consignments, 'retention' means the use of dunnage, braces, blocks or tie-downs, as appropriate, to restrain the package and prevent movement within or on a conveyance during routine transport.

When a freight container is used either to facilitate the transport of packaged radioactive material or to act as an overpack, consideration should be made for the packages to be restrained within the freight container. Methods of retention, for example, lashings, throw-over nets or compartmentalization, should be used to prevent damage to the packages when the freight container is being handled or transported. When a freight container or other large box type container is used as a packaging, consideration should be given to restraining the contents within the container to prevent damage to the container that might compromise the containment system or shielding integrity under the static and dynamic stresses resulting from handling and routine conditions of transport.

564.2. The retention of packages within or on conveyances is required for several reasons. By virtue of the movement of the conveyance during transport, small packages may be thrown or may tumble within or on their conveyances if not restrained, resulting in damage. Packages may also be dropped from the conveyance, resulting in their loss or damage. Heavy packages may shift position within or on a conveyance if not properly secured, which could make the conveyance unstable and could, thereby, cause an accident. Packages should also be restrained to avoid their movement in order to ensure that the radiation dose rate on the outside of the conveyance, to the driver or to the crew, is not increased.

564.3. For additional guidance on the methods of retention, see Appendix IV.

565.1. Some Type B(U), Type B(M) and Type C packages of radioactive material may give off heat. This is a result of radiation energy being absorbed in the components of the package as heat that is transferred to the surface of the package and thence to the ambient air. In such cases, heat dissipation capability is designed into the package and represents a safe and normal condition. For example, Co-60 produces approximately 15 W per 40 TBq. Since most of this is absorbed in the shielding of the package, the total heat load can be of the order of thousands of watts. The problem can be compounded if there are several similar packages in the shipment. As well as giving due consideration to the materials next to the packages, care should also be taken to ensure that the air circulation in any compartment containing the packages is not overly restricted so as to cause a significant increase in the ambient temperature in the immediate area of the packages. Carriers should be careful not to reduce the heat dissipation capability of the package(s) by covering them or overstuffing or close-packing with other cargo, which may act as thermal insulation. When packages of radioactive material give off significant heat, the consignor is required to provide the carrier with instructions on the proper stowage of the package (see para. 554).

565.2. Studies have shown that if the rate of generation of heat within a package is small (corresponding to a surface heat flux of less than 15 W/m^2), it can be dissipated by conduction alone and the temperature will not exceed 50°C , even if the package is completely surrounded by bulk loose cargo. The air gaps between packages allow sufficient dissipation to occur by air convection.

566.1. There are two primary reasons for limiting the accumulation of packages in groups, or in conveyances and freight containers. When packages are placed in close proximity, control is required to be exercised:

- (a) To prevent the creation of higher than acceptable dose rates as a result of the combined dose rates from individual packages. For consignments not carried under exclusive use,

this is done by placing a limit on the TI. The theoretical maximum dose rate at 2 m from the surface of a vehicle carrying a TI of 50 was historically calculated as 0.125 mSv/h, and considered to be equivalent to 0.1 mSv/h since the maximum was unlikely to be reached. Experience has confirmed the acceptability of these values.

- (b) To prevent criticality by limiting neutron interaction between packages containing fissile material. Restriction of the CSI to 50 in any one group of packages (100 under exclusive use) and the 6 m spacing between groups of packages provide this assurance.

566.2. For the transport of a freight container, more than one entry in Table 10 or Table 11 of the Transport Regulations might be applicable. As an example, for a large freight container to be carried on a seagoing vessel, there is no limit on either the TI or CSI for the total vessel, whereas there is a limitation on the TI and CSI in any one hold, compartment or defined deck area. It is also important to note that several requirements presented in the footnotes apply to certain shipments. These footnotes are requirements and are not just for information.

TABLE 2. SAMPLE SEGREGATION BETWEEN CLASSES

(taken from the IMDG Code [8])

Class	1.1	1.2	1.3	1.4	1.5	2.1	2.2	2.3	3	4.1	4.2	4.3	5.1	5.2	6.1	6.2	7	8	9
Explosives	1.1,	*	*	*	4	2	2	4	4	4	4	4	4	4	2	4	2	4	X
	1.2,																		
	1.5																		
Explosives	1.3,	*	*	*	4	2	2	4	3	3	4	4	4	4	2	4	2	2	X
	1.6																		
Explosives	1.4	*	*	*	2	1	1	2	2	2	2	2	2	2	X	4	2	2	X
Flammable gases	2.1	4	4	2	X	X	X	2	1	2	X	2	2	2	X	4	2	1	X
Non-toxic, non-flammable gases	2.2	2	2	1	X	X	X	1	X	1	X	X	1	X	2	1	1	X	X
Toxic gases	2.3	2	2	1	X	X	X	2	X	2	X	X	2	X	2	1	1	X	X
Flammable liquids	3	4	4	2	2	1	2	X	X	2	1	2	2	2	X	3	2	X	X

Class	1.1	1.3	1.4	2.1	2.2	2.3	3	4.1	4.2	4.3	5.1	5.2	6.1	6.2	7	8	9	
	1.2	1.6																
	1.5																	
Flammable solids (including self-reactive and related substances and desensitized explosives)	4.1	4	3	2	1	X	X	X	X	1	X	1	2	X	3	2	1	X
Substances liable to spontaneous combustion	4.2	4	3	2	2	1	2	2	1	X	1	2	2	1	3	2	1	X
Substances that, in contact with water, emit flammable gases	4.3	4	4	2	X	X	X	1	X	1	X	2	2	X	2	2	1	X
Oxidizing substances (agents)	5.1	4	4	2	2	X	X	2	1	2	2	X	2	1	3	1	2	X
Organic peroxides	5.2	4	4	2	2	1	2	2	2	2	2	2	X	1	3	2	2	X
Toxic substances	6.1	2	2	X	X	X	X	X	X	1	X	1	1	X	1	X	X	X
Infectious substances	6.2	4	4	4	4	2	2	3	3	3	2	3	3	1	X	3	3	X
Radioactive material	7	2	2	2	2	1	1	2	2	2	2	1	2	X	3	X	2	X
Corrosive substances	8	4	2	2	1	X	X	X	1	1	1	2	2	X	3	2	X	X

Class		1.1	1.3	1.4	2.1	2.2	2.3	3	4.1	4.2	4.3	5.1	5.2	6.1	6.2	7	8	9
		1.2	1.6															
		1.5																
Miscellaneous dangerous substances and articles	9	X	X	X	X	X	X	X	X	X	X	X	X	X	X	X	X	X

Numbers and symbols relate to the following terms as defined in Chapter 7 of the IMDG Code [8]:

1 — “Away from”.

2 — “Separated from”.

3 — “Separated by a complete compartment or hold from”.

4 — “Separated longitudinally by an intervening complete compartment or hold from”.

X — The segregation, if any, is shown in the Dangerous Goods List of the IMDG Code [8].

* — See section 7.2.7.2 of the IMDG Code [8].

566.3. Where a consignment is transported under exclusive use, there is no limit on the TI aboard a single conveyance. Likewise, for consignments of LSA-I material, there is no limit on the TI aboard a single conveyance.

567.1. Any consignment with a CSI greater than 50 is required to be transported under exclusive use (see para. 526.1). The loading arrangement assumed in the criticality assessment of paras 684 and 685 consists of an arrangement of identical packages. Ref. [40] provides a discussion of theoretical packaging arrangements that mix the package designs within the array and indicate the possibility for an increase in the neutron multiplication factor in comparison with an arrangement of identical packages. Although such arrangements are unlikely in practice, care should be taken in establishing the loading arrangement for shipments where the CSI exceeds 50. Attention should also be paid to ensuring that packages of mixed design are properly arranged so as to maintain a safe configuration [41]. Where the CSI for a shipment exceeds 50, there is also a requirement to obtain shipment approval (see para. 825).

Additional requirements relating to transport and storage in transit of fissile material

568.1. The requirement to maintain a spacing of 6 m is necessary for criticality control. Where two storage areas are divided by a wall, floor or similar boundary, storage of the packages, overpacks and freight containers on opposite sides of the separating physical boundary still has to meet the requirements for 6 m segregation.

569.1. See para. 568.1.

570.1. In para. 570(a) and (b), mixing of packages on the basis of different provisions or approvals in the same consignment is prohibited because the safety of the mixture under accident conditions of transport has not been demonstrated. If an applicant wishes to mix packages excepted by one certificate under para. 417(f) with packages excepted by another certificate under para. 417(f) in the same consignment, the safety of the mixture under accident conditions has to be demonstrated and specified in the approval certificate.

570.2. The basis for a 45 g consignment limit in subpara (c) and (e) is given in para. 417.5. A 15 g consignment limit was set, not for a technical or a safety reason, but for a practical reason (i.e. to have the same limit as a limit which already exists in another area, namely physical protection [43]).

Additional requirements relating to transport by rail and by road

571.1. See paras 543.1 and 544.1.

572.1. See para. 544.1.

573.1. The maximum dose rate should be determined taking into account potentially significant amplifying phenomena such as internal movement of contents, or, in the case of packages containing liquids, segregation and precipitation of the radionuclides. These phenomena need to be taken into account by applying a correction factor to the maximum dose rate measured at the external surface of the package or overpack, and at the surface and at 2 m from the vehicle or by using a maximum value instead. This correction factor or maximum value should be provided in the package instructions for use. In any case, a dose rate measurement should be performed before shipment, and the maximum potential dose rate should be determined by taking into account any such factors. See paras 221.1–221.6 on exclusive use.

573.2. In most cases, the dose rate at any point on the external surface of a package is limited to 2 mSv/h. For road and rail transport, when transported under exclusive use, packages and overpacks are allowed to exceed 2 mSv/h if access to the enclosed areas in the vehicle is restricted. Restricting access to these areas may be achieved by using an enclosed vehicle that can be locked, or by bolting and locking a cage over the package. In some cases, the open top of a vehicle with side walls may be covered with a tarpaulin, but this type of enclosure would generally not be considered adequate for preventing access.

573.3. During transit, there should be no entering into the enclosed area of a vehicle. If the vehicle is being held in the carrier's compound for any period, it should be parked in an area where access is controlled and where people are not likely to remain in close proximity for an extended period. If maintenance work is required to be done on the vehicle for an extended period, then arrangements should be made with the consignor or the consignee to ensure adequate radiation protection, for example, by providing extra shielding and radiation monitoring.

573.4. It is essential to secure a package or overpack to prevent movement during transport that could cause the dose rate to exceed relevant limits or increase the dose to the vehicle driver. For road transport, a package or overpack should be secured against forces resulting from acceleration, braking and turning, as expected during normal conditions of transport. For rail transport, packages should also be secured to prevent movement during shunting. (See paras 564.1–564.3.)

573.5. In establishing the dose rate for a conveyance, account may be taken of additional shielding within the conveyance. However, the integrity of the shielding should be maintained during routine transport; otherwise, compliance with the conveyance dose rate limit may not be maintained.

573.6. While it is a requirement of para. 573(a)(iii) of the Transport Regulations that there is no loading or unloading during the shipment of consignments under exclusive use to allow extending the dose rate limit to 10 mSv/h at any point on the external surface of any package or overpack, this does not preclude a carrier who is consolidating consignments from more than one place to assume the role and responsibility of the consignor for a combined consignment and being so designated for the purpose of the subsequent exclusive use shipment.

573.7. For SCO-III, paras. 573(b) and 573(c) apply. The dose rate at the surface of the SCO-III is limited as specified in para. 517. In the case of a SCO-III with a surface dose rate greater than 2 mSv/h, precautions to prevent access of unauthorized persons where the dose rate is greater than 2 mSv/h, and to secure the object, limit risk during loading or unloading, and any other relevant precautions, should be specified in the transport plan.

574.1. The restrictions placed upon the persons who are permitted in vehicles carrying packages that might have significant dose rates are to prevent unnecessary or uncontrolled exposures of persons.

574.2. The term 'assistant' should be interpreted as meaning any worker, being subject to the requirements of para. 303, whose business in the vehicle concerns either the vehicle itself or the radioactive consignment. It could not, for example, include any members of the public or passengers whose sole purpose in the vehicle is to travel. It could, however, include an inspector or health physics monitor in the course of their duties.

574.3. Vehicles should be loaded in such a way that the dose rate in occupied positions is minimized. This may be achieved by placing packages with higher dose rates furthest away from the occupied area and by placing heavy packages with low dose rates nearer to the occupied position. During loading and unloading, direct handling times should be minimized and the use of handling devices such as nets

or pallets should be considered in order to increase the distance of packages from the body. Personnel should be prevented from lingering in areas where significant dose rates exist.

Additional requirements relating to transport by vessels

575.1. Each mode of transport has its own unique features. In the case of transport by sea, the possibility of journey times of weeks or months and the need for continued routine inspection throughout the journey might lead to significant exposures during the carriage of the radioactive material. Simply having the exclusive use of a hold, compartment or defined deck area, particularly the latter, was not considered as providing sufficient protection from high dose rate packages. Two further restrictions were therefore introduced for packages having a surface dose rate greater than 2 mSv/h: (i) either they are in (or on) a vehicle or (ii) they are transported under special arrangement. Access and dose rates are therefore controlled by the requirements of para. 573 for vehicles, or by controls relevant to particular circumstances prescribed by the competent authority under the terms of the special arrangement.

575.2. Transport by sea of any package having a surface dose rate exceeding 2 mSv/h is required to be done under special arrangement, except when transported in or on a vehicle under exclusive use and when subject to the conditions of para. 574. However, if the latter situation occurs, it may be desirable for purposes of radiation protection that a specific area be allocated for that vehicle by the master of the ship or the competent authority concerned. This would be appropriate, in particular, for the transport of such vehicles aboard roll-on/roll-off vessels such as ferries. Further guidance is given in the IMDG Code [8].

576.1. The simple controls on the accumulation of packages as a means of limiting radiation exposure (para. 566) may not be appropriate for ships dedicated to the transport of radioactive material. Since the vessel itself may be transporting consignments from more than one consignor, it could not be considered as being under exclusive use, and the requirements of Tables 10 and 11 of the Transport Regulations might therefore be unnecessarily restrictive.

576.2. Special use vessels employed for the transport by sea of radioactive material have been adapted and/or dedicated specifically for this purpose. The radiation protection programme covering transport by such vessels should be based upon preplanned stowage arrangements specific to the vessel in question and to the number and the nature of the packages to be carried. The radiation protection programme should take into account the nature and the intensity of the radiation likely to be emitted by packages; occupancy factors based on the planned maximum duration of voyages should also be taken into account. This information should be used to define stowage locations in relation to regularly occupied working spaces and living accommodation, in order to ensure adequate radiological protection of persons. The competent authority, normally the competent authority of the flag State of the vessel, may specify the maximum number of packages permitted, their identity and contents, the precise stowage arrangements to be observed and the maximum dose rates permitted at key locations. The radiation protection programme would normally require that appropriate monitoring be carried out during and after completion of stowage, as necessary, to ensure that specified doses or dose rates are not exceeded. Details of the results of such surveys, including any checks for contamination of packages and of cargo spaces, should be provided to the competent authority on request.

576.3. For packages containing fissile material, the programme should also take appropriate account of the need for criticality control.

576.4. Although not directly part of an RPP, limitations on stowage associated with the heat output from each package should be considered. The means for heat removal, both natural and mechanical,

should be assessed for this purpose, and heat outputs for individual packages should be specified, if necessary.

576.5. Records of measurements taken during each voyage should be supplied to the competent authority on request. This is one method of ensuring that the RPP and any other controls have functioned adequately.

576.6. 'Persons qualified in the carriage of radioactive material' should be taken to mean persons who possess appropriate special knowledge of the handling of radioactive material.

576.7. Consignors and carriers of irradiated nuclear fuel, plutonium or high level radioactive waste wishing to transport these materials by sea are advised to refer to the Code for the Safe Carriage of Irradiated Nuclear Fuel, Plutonium and High-Level Radioactive Wastes in Flasks on Board Ships (INF Code) [9]. This code assigns ships carrying these materials to one of three classes, depending on the total activity of radioactive material that may be carried, and lays down requirements for each class concerning damage stability, fire protection, temperature control of cargo spaces, structural considerations, cargo securing arrangements, electrical supplies, radiological protection equipment and management, training and shipboard emergency plans.

Additional requirements relating to transport by air

577.1. This requirement relates to the presence of passengers on an aircraft rather than its capability to carry passengers. Referring to para. 203, an aircraft equipped to carry passengers, but which is carrying no passengers on the flight concerned, may meet the definition of a cargo aircraft and may be used for the transport of Type B(M) packages and of consignments under exclusive use.

578.1. The special conditions of air transport would result in an increased level of hazard in the case of the types of package described in para. 578. There may be a considerable reduction in ambient air pressure at the cruising altitudes of aircraft. This is partially compensated for by a pressurization system, but such a system is never considered to be 100% reliable.

578.2. If venting were permitted, this would increase considerably as the outside pressure is reduced and it would be difficult to design for this to occur safely. Ancillary cooling and other operational controls would be difficult to ensure within an aircraft under normal and accident conditions.

578.3. Any liquid pyrophoric material poses a special hazard to an aircraft in flight and severe limitations apply to such materials. Where a radioactive substance having the subsidiary hazard of pyrophoricity is also a liquid, there is a greater probability of a spill occurring and it is therefore forbidden to transport such a substance by air.

579.1. For packages or overpacks having a surface dose rate greater than 2 mSv/h, greater care is necessary in loading and handling. The requirement for such consignments to be transported by special arrangement ensures the involvement of the competent authority and allows special handling precautions to be specified, either during loading, in flight or at any intermediate transfer point.

579.2. The special arrangement authorization should include consideration of handling, loading and in-flight arrangements in order to control the radiation doses to flight crew, ground support personnel and incidentally exposed persons. This may necessitate special instructions for crew members, notification to appropriate persons such as terminal staff at the destination and at intermediate points and special consideration of transfer to other transport modes.

Additional requirements relating to transport by post

580.1. When shipping by post, special attention should be paid to national postal regulations to ensure that shipments are acceptable to national postal authorities.

580.2. For movement by post, the allowed levels of activity are only one tenth of those allowed for excepted packages by other modes of transport, for the following reasons:

- (a) The possibility exists of contaminating a large number of letters and other items in the post, which would subsequently be widely distributed, thus increasing the number of persons exposed to the contamination.
- (b) This reduction would result in a corresponding reduction in the maximum dose rate from a source that has lost its shielding, and this is considered to be suitably conservative in the postal environment in comparison with other modes of transport.
- (c) A single mailbag might contain a large number of such packages.

581.1. When authorization is given to an organization for the use of the postal service, a suitably knowledgeable and responsible individual should be appointed within that organization to ensure that the correct procedures and limitations are observed.

CUSTOMS OPERATIONS

582.1. The fact that a consignment contains radioactive material does not, by itself, constitute a reason to exclude such consignments from normal customs operations. However, because of the radiological hazards involved in examining the contents of a package containing radioactive material, the examination of the contents of packages should be carried out under suitable radiation protection conditions. A person with adequate knowledge of handling radioactive material and who is capable of making sound radiation protection judgements should be present to ensure that the examination is carried out without any undue radiation exposure of customs staff or any third party.

582.2. Transport safety depends, to a large extent, on safety features built into the package. Thus, no customs operation should diminish the safety inherent in the package, when the package is to be subsequently forwarded to its destination. Again, a qualified person should be present to help ensure the adequacy of the package for its continued transport. A 'qualified person' in this context means a person who has expertise in applying the regulatory requirements for transport as well as in the preparation of the package containing the radioactive material for onward transport.

582.3. For the examination of packages containing radioactive material by customs officials:

- (a) Clearance formalities should be carried out as quickly as possible, to eliminate delays in customs clearance that might decrease the usefulness of valuable radioactive material.
- (b) Any necessary internal inspection of packages should be carried out in places where adequate facilities are available and radiation protection precautions can be implemented by qualified persons.

582.4. Customs officials should keep in mind that some packages are used repeatedly and because of this, packages may show some degradation of the external surface and may also exhibit staining and small flaws caused by normal conditions of transport. This does not mean that the package is unable to fulfil its safety functions. If there is any doubt, and if it is noted that a package has been damaged, the customs official should immediately provide the necessary information to a qualified person and follow the instructions of that qualified person. No person should be allowed either to remain near the package

(a segregation distance of 3 m would generally be sufficient) or to touch it unless absolutely necessary. If handling is necessary, some form of protection should be used to avoid direct contact with the package. After handling, it is advisable to wash hands.

582.5. When necessary, packages should be placed for temporary storage in an isolated, secure place. During such storage, the segregation distance between the packages and all persons should be as large as practicable. Warning signs should be posted around the package and storage area. Further information should be obtained from the consignor, consignee, or competent authority.

UNDELIVERABLE CONSIGNMENTS

583.1. For segregation, see paras 562.1–562.14 and 568.1.

RETENTION AND AVAILABILITY OF TRANSPORT DOCUMENTS BY CARRIERS

584.1. Paragraphs 584–588 were reproduced from Part 7, Chapter 1, paragraph 1.2 of the ICAO Technical Instructions [12] to the 2012 Edition of the Transport Regulations. These provisions are for States that have not implemented modal transport regulations to their national regulations, but have implemented the Transport Regulations as their national regulations for the safe transport of radioactive material.

REFERENCES TO SECTION V

- [1] UNITED KINGDOM ATOMIC ENERGY AUTHORITY, Shielding Integrity Testing of Radioactive Material Transport Packaging: Gamma Shielding, Rep. AECF 1056, Part 1, UKAEA, Harwell, UK (1977).
- [2] UNITED KINGDOM ATOMIC ENERGY AUTHORITY, Testing the Integrity of Packaging Radiation Shielding by Scanning with Radiation Source and Detector, Rep. AESS 6067, UKAEA, Risley, UK (1977).
- [3] BRITISH STANDARDS INSTITUTE, Guide to the Design, Testing and Use of Packaging for the Safe Transport of Radioactive Materials, BS 3895:1976, GR 9, BSI, London (1976).
- [4] AMERICAN NATIONAL STANDARDS INSTITUTE, American National Standard for Leakage Tests on Packages for Shipment of Radioactive Material, ANSI N14.5-2014, ANSI, New York (2014).
- [5] INTERNATIONAL ORGANIZATION FOR STANDARDIZATION, Safe Transport of Radioactive Material — Leakage Testing on Packages, ISO 12807:2018(E), ISO, Geneva (2018).
- [6] INTERNATIONAL ATOMIC ENERGY AGENCY, Methodology for a Safety Case for a Dual Purpose Cask for Storage and Transport of Spent Fuel, IAEA-TECDOC-****, IAEA, Vienna (201*) (under publication).
- [7] ZACHAR, M., PRETESACQUE, P., Burnup credit in spent fuel transport to COGEMA La Hague reprocessing plant, *Int. J. Radioact. Mater. Transp.* **5** 2–4 (1994) 273–278.

- [8] INTERNATIONAL MARITIME ORGANIZATION, International Maritime Dangerous Goods (IMDG) Code, 2016 Edition, IMO, London (2016).
- [9] INTERNATIONAL MARITIME ORGANIZATION, Code for the Safe Carriage of Irradiated Nuclear Fuel, Plutonium and High-Level Radioactive Wastes in Flasks on Board Ships (INF Code), Resolution MSC.178(79), IMO, London (2004).
- [10] UNITED NATIONS ECONOMIC COMMISSION FOR EUROPE, INLAND TRANSPORT COMMITTEE, European Agreement Concerning the International Carriage of Dangerous Goods by Road (ADR), 2017 Edition, UNECE, New York and Geneva (2016).
- [11] UNITED NATIONS ECONOMIC COMMISSION FOR EUROPE, INLAND TRANSPORT COMMITTEE, European Agreement Concerning the International Carriage of Dangerous Goods by Inland Waterways (ADN), 2011 Edition, UNECE, Geneva (2011).
- [12] INTERNATIONAL CIVIL AVIATION ORGANIZATION, Technical Instructions for the Safe Transport of Dangerous Goods by Air, 2017–2018 Edition, ICAO, Montreal (2017).
- [13] INTERGOVERNMENTAL ORGANIZATION FOR INTERNATIONAL CARRIAGE BY RAIL (OTIF), Regulations Concerning the International Carriage of Dangerous Goods by Rail (RID), 2017 Edition, OTIF, Berne (2016).
- [14] INTERNATIONAL AIR TRANSPORT ASSOCIATION, Dangerous Goods Regulations, 59th Edition, IATA, Montreal (2018).
- [15] UNIVERSAL POSTAL UNION, Universal Postal Convention of Rio de Janeiro, UPU, Berne (1979).
- [16] UNITED NATIONS, Recommendations on the Transport of Dangerous Goods, Model Regulations, Twentieth Revised Edition (ST/SG/AC.10/1/Rev.20), UN, New York and Geneva (2017).
- [17] FAIRBAIRN, A., “The derivation of maximum permissible levels of radioactive surface contamination of transport containers and vehicles”, Regulations for the Safe Transport of Radioactive Materials — Notes on Certain Aspects of the Regulations, Safety Series No. 7, IAEA, Vienna (1961).
- [18] INTERNATIONAL ATOMIC ENERGY AGENCY, Radiological Aspects of Non-fixed Contamination of Packages and Conveyances, IAEA-TECDOC-1449, IAEA, Vienna (2005).
- [19] WRIXON, A.D., LINSLEY, G.S., BINNS, K.C., WHITE, D.F., Derived Limits for Surface Contamination, Harwell, Rep. NRPB-DL2, HMSO, London (1979).
- [20] INTERNATIONAL ATOMIC ENERGY AGENCY, Monitoring of Radioactive Contamination on Surfaces, Technical Reports Series No. 120, IAEA, Vienna (1970).

- [21] INTERNATIONAL COMMISSION ON RADIOLOGICAL PROTECTION, The 2007 Recommendations of the International Commission on Radiological Protection, ICRP, Publication 103, Ann. ICRP 37 (2-4), 2007.
- [22] FAW, R.E., Absorbed doses to skin from radionuclide sources on the body surface, *Health Phys.* **63** (1992) 443–448.
- [23] TRAUB, R.J., REECE, W.D., SCHERPELZ, R.I., SIGALLA, L.A., Dose Calculations for Contamination of the Skin Using the Computer Code VARSKIN, Rep. PNL-5610, Battelle Pacific Northwest Labs, Richland, WA (1987).
- [24] KOCHER, D.C., ECKERMAN, K.F., Electron dose-rate conversion factors for external exposure of the skin from uniformly deposited activity on the body surface, *Health Phys.* **53** (1987) 135–141.
- [25] FOOD AND AGRICULTURE ORGANIZATION OF THE UNITED NATIONS, INTERNATIONAL ATOMIC ENERGY AGENCY, INTERNATIONAL LABOUR ORGANIZATION, OECD NUCLEAR ENERGY AGENCY, PAN AMERICAN HEALTH ORGANIZATION, WORLD HEALTH ORGANIZATION, Radiation Protection and Safety of Radiation Sources: International Basic Safety Standards, IAEA Safety Standards Series No. GSR Part 3, IAEA, Vienna (2014).
- [26] LAUTERBACH, U., “Radiation level for low specific activity materials in compact stacks”, Packaging and Transportation of Radioactive Materials, PATRAM 80 (Proc. Int. Symp. Berlin, 1980), Bundesanstalt für Materialprüfung, Berlin (1980).
- [27] FAIRBAIRN, A., The development of the IAEA Regulations for the Safe Transport of Radioactive Materials, *At. Energy Rev.* **11** 4 (1973) 843.
- [28] GELDER, R., Radiation Exposure from the Normal Transport of Radioactive Materials within the United Kingdom, Rep. NRPB-M255, National Radiological Protection Board, Chilton, UK (1991).
- [29] HAMARD, J., et al., “Estimation of the individual and collective doses received by workers and the public during the transport of radioactive materials in France between 1981 and 1990”, Packaging and Transportation of Radioactive Materials, PATRAM 92 (Proc. Int. Symp. Yokohama City, 1992), Science and Technology Agency, Tokyo (1992).
- [30] KEMPE, T.F., GRODIN, L., “Radiological impact on the public of transportation for the Canadian Nuclear Fuel Waste Management Program”, Packaging and Transportation of Radioactive Materials, PATRAM 89 (Proc. Int. Symp. Washington, DC, 1989), Oak Ridge Natl Lab., TN (1989).
- [31] GELDER, R., Radiological Impact of the Normal Transport of Radioactive Materials by Air, Rep. NRPB M219, National Radiological Protection Board, Chilton, UK (1990).

- [32] INTERNATIONAL ATOMIC ENERGY AGENCY, Assessment of the Radiological Impact of the Transport of Radioactive Materials, IAEA-TECDOC-398, IAEA, Vienna (1986).
- [33] DOARE, O., DIESCHBOURG, K., HUET, C., SERT, G., “UF6 release calculations and radiological and environmental impacts of a UF6 container subject to a long duration fire”, Packaging and Transportation of Radioactive Materials, PATRAM 2001 (Proc. Int. Symp. Chicago, 2001), Department of Energy, Washington, DC (2001).
- [34] WILSON, C.K., The air transport of radioactive materials, Radiat. Prot. Dosim. **48** (1993) 129–133.
- [35] WILSON, C.K., SHAW, K.B., GELDER, R., “Radiation doses arising from the sea transport of radioactive materials”, Packaging and Transportation of Radioactive Materials, PATRAM 89 (Proc. Int. Symp. Washington, DC, 1989), Oak Ridge Natl Lab., TN (1989).
- [36] WAMER JONES, S.M., SHAW, K.B., HUGHES, J.S., Survey into the Radiological Impact of the Normal Transport of Radioactive Material by Air — Final Report, Rep. NR PB-W39, National Radiological Protection Board, Chilton, UK (2003).
- [37] GELDER, R., SCHWARZ, G., SHAW, K., LANGE, F., “Segregation of packages during transport”, Packaging and Transportation of Radioactive Materials, PATRAM 98 (Proc. Int. Symp. Paris, 1998), Vol. 3, Institut de protection et de sûreté nucléaire, Paris (1998).
- [38] INTERNATIONAL ATOMIC ENERGY AGENCY, Establishment of Source Related Dose Constraints for Members of the Public: Interim Report for Comment, IAEA-TECDOC-664, IAEA, Vienna (1992).
- [39] INTERNATIONAL ATOMIC ENERGY AGENCY, Regulatory Control of Radioactive Discharges to the Environment, IAEA Safety Standards Series No. GSG-9, IAEA, Vienna (in preparation).
- [40] MENNERDAHL, D., “Mixing of package designs: Nuclear criticality safety”, Packaging and Transportation of Radioactive Materials, PATRAM 86 (Proc. Int. Symp. Davos, 1986), IAEA, Vienna (1987) 167–175.
- [41] BOUDIN, X., et al., “Rule relating to the mixing of planar arrays of fissile units”, Physics and Methods in Criticality Safety (Proc. Top. Mtg Nashville, TN), American Nuclear Society, La Grange Park, IL (1993) 102–111.
- [42] MIHALCZO, J.T., et al., “Feasibility of subcriticality and NDA measurements for spent fuel by frequency analysis techniques with ^{252}Cf ”, Nuclear Plant Instrumentation, Control and Human-Machine Interface Technologies (Proc. Int. Top. Mtg College Station, PA, 1996), Vol. 2, American Nuclear Society, La Grange Park, IL (1996) 883–891.

- [43] INTERNATIONAL ATOMIC ENERGY AGENCY, Nuclear Security Recommendations on Physical Protection of Nuclear Material and Nuclear Facilities (INFCIRC/225/Revision 5), IAEA Nuclear Security Series No. 13, IAEA, Vienna (2011).

Section VI

REQUIREMENTS FOR RADIOACTIVE MATERIAL AND FOR PACKAGINGS AND PACKAGES

REQUIREMENTS FOR RADIOACTIVE MATERIAL

Requirements for special form radioactive material

602.1. Special form radioactive material is required to be of a reasonable size to enable it to be easily salvaged or found after an incident or loss; hence the restriction on minimum size. The figure of 5 mm is arbitrary but practical and reasonable, bearing in mind the type of material normally classified as special form radioactive material.

603.1. The Transport Regulations seek to ensure that a package containing special form radioactive material will not release or disperse its radioactive contents (by leakage from the sealed capsule or by dispersion or leaching of the radioactive material itself) during a severe accident, even though the packaging may be destroyed (see Appendix I). This minimizes the predicted hazards from inhalation or ingestion of, or from contamination by, the radioactive material. For this reason, special form radioactive material is required to be able to survive severe mechanical and thermal tests analogous to the tests applied to Type B(U) packages without undue loss or dispersal of radioactive material at any time during its working life.

603.2. The applicant should demonstrate that the solubility of the material evaluated in the leaching test is equal to or greater than that of the actual radioactive material to be transported. Results should also be extrapolated if material with reduced radioactive contents is used in the test, in which case the validity of the extrapolation should be demonstrated. The applicant should not assume that simply because a material is inert it will pass the leach test without being encapsulated. For example, bare encapsulated Ir-192 pellets have failed the leach test [1]. Leaching values should be scaled up to values that reflect the total activity and form that will be transported. In section 3.4 of ISO 2919 [2], a sealed source is defined as leachable if the quantity of released material is greater than 0,1 mg/g in 100 ml of still water maintained at 50 °C for 4 h; the test conditions should be those described in section 5.1.1 of ISO 9978:1992 [3]. For material enclosed in a sealed capsule, suitable volumetric leakage assessment techniques, such as vacuum bubble or helium leakage test methods, may be used. In this case, all test parameters that have an effect on sensitivity need to be thoroughly specified and taken into account in evaluating the implied loss of radioactive material from the special form radioactive material.

603.3. The Transport Regulations allow alternative leakage assessment tests for sealed capsules. When, by agreement with the competent authority concerned, the performance tests of a capsule design are not conducted with radioactive contents, the leakage assessment may be made by a volumetric leakage method. A rate of 10^{-5} Pa·m³·s⁻¹ for non-leachable solid contents and a rate of 10^{-7} Pa·m³·s⁻¹ for leachable solids, liquids and gases would, in most cases, be considered to be equivalent to the release limit of 2 kBq prescribed in para. 603 [3]. Volumetric leakage test methods are suitable for detecting leaks in sealed sources; these are listed in Table 3 together with their sensitivities.

603.4. When using non-radioactive material as a surrogate, the measurement of leaked material should be related to the limit of 2 kBq specified in para. 603(c) of the Transport Regulations.

TABLE 3. COMPARISON OF THE FOUR VOLUMETRIC LEAKAGE TEST METHODS RECOMMENDED BY REF. [4]

Leakage test method	Sensitivity (Pa·m ³ ·s ⁻¹)	Minimum void in capsule (mm ³)
Vacuum bubble		
(i) glycol or isopropyl alcohol	10 ⁻⁶	10
(ii) water	10 ⁻⁵	40
Pressurized bubble with isopropyl alcohol	10 ⁻⁸	10
Liquid nitrogen bubble	10 ⁻⁸	2
Helium pressurization	10 ⁻⁸	10

604.1. Where a sealed capsule constitutes part of the special form radioactive material, it should be ensured that the capsule offers no possibility of being opened by normal handling or unloading measures. Otherwise, the possibility could arise that the radioactive material is handled or transported without the protective capsule.

604.2. Sealed sources that can be opened only by destructive techniques are generally assumed to be those of welded construction. They can be opened only by methods such as machining, sawing, drilling or flame cutting. Capsules with threaded end caps or plugs, for example, which may be opened without destroying the capsule, would not be acceptable.

Requirements for low dispersible radioactive material

605.1. Limiting the external dose rate at 3 m from the unshielded LDRM to 10 mSv/h ensures that the potential external dose is consistent with the potential consequences of severe accidents involving industrial packages (see para. 517).

605.2. Particles up to about 10 µm aerodynamic equivalent diameter³ are respirable and can reach deeper regions of the lung, where clearance times may be long. Particles between 10 µm and 100 µm aerodynamic equivalent diameter are of little concern for the inhalation pathway, but they can contribute to other exposure pathways after deposition. Particles greater than 100 µm aerodynamic equivalent diameter deposit very quickly. While this could lead to a localized contamination in the immediate vicinity of the accident, it would not represent a significant mechanism for internal exposure.

605.3. For LDRM, the airborne release in gaseous or particulate form is limited to 100A₂ when subjecting the contents (to be transported in a Type B(U) or Type B(M) package design including the LDRM in question) to the mechanical and thermal tests. This 100A₂ limit refers to all particle sizes up

³ The aerodynamic equivalent diameter (also known as aerodynamic diameter) of an airborne particle is the diameter that a sphere of unit density would need to have in order to have the same terminal velocity when settling in air as the particle of interest.

to 100 μm aerodynamic equivalent diameter. Airborne releases can lead to radiation exposure of persons in the downwind direction from the location of an aircraft accident via several exposure pathways. Of primary concern is a short term intake of radioactive material through inhalation. Other pathways are less important because their contribution is only relevant for long residence times, and remedial actions can be taken to limit exposure. For the inhalation pathway, particles below about 10 μm aerodynamic equivalent diameter predominate because they are respirable. Nevertheless, a cautiously chosen upper limit of 100 μm was introduced in connection with the 100A₂ limit. The rationale is that in this way it is ensured that neither the inhalation pathway nor other exposure pathways following deposition could lead to unacceptable radiation doses.

605.4. When LDRM is subjected to the high velocity impact test (see para. 737), particulate matter can be generated, but of the airborne particulates up to 100 μm , only a small fraction (less than 10%) will be expected to be in the respirable size range below 10 μm . Therefore, the airborne release of respirable particles of LDRM is expected to be less than 10A₂, if the 100A₂ limit specified in 605 (b) for the airborne particulates up to 100 μm is met. It has been shown that for a reference distance of around 100 m and for a wide range of atmospheric dispersion conditions this would lead to an effective dose below 50 mSv.

605.5. For the specimen undergoing the impact test, consideration should be given to the physical interactions among source structures and individual material components comprising the LDRM. These interactions may result in a substantial change of the form of the LDRM. For example, a single fuel pellet may not produce the same quantity of dispersible material after a high velocity impact as the same pellet incorporated with other pellets into a fuel rod. It is important that the tested specimen be representative of the LDRM that will be transported.

605.6. In the case of the enhanced thermal test (see para. 736), an airborne release of up to 100A₂ of LDRM could occur, in gaseous form or as particulate with predominantly small (<10 μm aerodynamic equivalent diameter) particle sizes because thermal processes such as combustion generally result in small particulates. Attention should be paid to the potential chemical changes of the materials during the enhanced thermal test that could lead to aerosol generation, for example, chemical reactions induced by combustion products. In the case of a fire following an aircraft accident, buoyancy effects of the hot gases would lead to ground level air concentrations and to potential effective inhalation doses, which would also remain below 50 mSv for a wide range of atmospheric dispersion conditions.

605.7. The limit on leaching of radioactive material is applied to LDRM to eliminate the possibility of dissolution and migration of radioactive material, causing significant contamination of land and watercourses, even if the LDRM were completely released from the packaging in a severe accident. The 100A₂ limit for leaching is the same as that for the release of airborne material as a result of a fire or high velocity impact.

605.8. For the leaching test the specimen should incorporate a representative sample of the LDRM that has been subjected to the enhanced thermal test and the high velocity impact test. A separate specimen may be used for each test, in which case two samples would be subjected to the leach test. For example, in the case of the impact test, the material could be broken up or otherwise separated into various solid forms, including deposited powder-like material. These forms constitute the LDRM that should be subjected to the leaching test.

605.9. It is especially important that the measurements of airborne releases and leached material be reproducible.

REQUIREMENTS FOR MATERIAL EXCEPTED FROM FISSILE CLASSIFICATION

606.1. Paragraph 805 permits applicants to request multilateral approval for a specified fissile material to be treated as subcritical without the need for accumulation control and other controls during shipment and without needing a specific packaging. Ideally, these fissile materials will be subcritical in infinite quantities (i.e. $k_{\infty} < 1$). When applied in para. 417(f), this approach is consistent with the existing provisions of para. 417(a) and (b). The applicant will need to make certain that the specified fissile material is (or will be) appropriately characterized. A safety analysis is required to be prepared (see para. 805) with a detailed justification that the material will remain subcritical under routine, normal and accident conditions as specified within the Transport Regulations. The justification should make reference to calculations, sampling (e.g. of waste streams), testing of material samples, records (e.g. fissile inventories) and reasoned argument, as appropriate. If possible, compliance with the requirements in para. 606(b) should be met only by the “bare” fissile material without any benefit taken from the characteristics of the type of packaging in which the fissile material will be transported.

606.2. Examples of cases that could be deemed appropriate would be those where k_{∞} of the material is adequately subcritical, or where the mass and/or volume of material necessary to cause a criticality hazard is too large to be of practical concern.

Safety will be ensured because the fissile nuclides are distributed among significant quantities of non-fissile material.

It should be demonstrated that changes to the distribution of the fissile nuclides (e.g. the fissile:non-fissile ratio) that could reasonably occur during routine, normal and accident conditions of transport will not compromise criticality safety.

The conditions listed in para. 673(a) are required to be considered in assessing the safety of the material, in particular, the addition of water from an external source is required to be considered.

The transport of the material should be safe over the temperature range specified in para. 679. Otherwise, operational controls should be imposed to limit transport to specified ambient temperatures.

Packages containing material excepted under the provisions of para. 417(f) are intended to be safe without accumulation control and this should be met by demonstrating that the k_{∞} of the material is lower than 1. Alternatively, an argument should be made that, although k_{∞} is equal to or greater than 1, the quantity of material required to obtain an unsafe k_{eff} could not conceivably occur during transport. This is consistent with para. 686, which permits ‘N’ to be ‘effectively equal to infinity’ rather than the requirement that it be truly infinite.

Where the radioactive nature of the material requires the use of a certain minimum package Type (e.g. Type A, B(U) or B(M)), then credit may be taken for this. Alternatively, it may be possible to specify that a certain package type (but not design) be used. Only those packaging requirements in Section VI of the Transport Regulations for the package type used may be claimed. If it is necessary to claim specific features of a specific package or design, then the exception of the material is not appropriate and an application for approval of a package design for fissile material should be made. Package design approval requires the detailed specification of a packaging, in contrast to this paragraph. This is the essential difference between the two types of approval.

606.3. The safety analysis substantiating the application for multilateral approval of a specified fissile material to be excepted from fissile classification should include:

(a) The specification of the fissile nuclides and non-fissile material;

- (b) The distribution of fissile nuclides among the non-fissile material (e.g. homogeneity and uniformity);
- (c) How items (a) and (b) may change under routine, normal and accident conditions (e.g. physical form, flammability, solubility, separability) and the subsequent requirements on stability (e.g. solid, non-flammable, non-soluble, non-separable) of the non-fissile material.

606.4. Regarding para. 606(b), references to “package” in paras 684(b) and 685(b) should be interpreted as the fissile material together with any packaging required for radiological safety during normal and accident conditions [5].

606.5. A simple example of a material that could comply with the requirements of para. 606 is burnable absorber pellets and rods where at least 2% by mass of Gd_2O_3 is mixed with low enriched uranium oxides and then pressed and sintered before shipment.

606.6. An example of a material that should not be considered as complying with para. 606 is enriched uranium hexafluoride, as criticality safety relies on moderation control. The argument that containment is also required to prevent chemical and radiological hazards should not be used to restrict criticality safety assessment to dry uses of uranium hexafluoride.

606.7. An example can be found within Ref. [6] in which exceptions are permitted for materials containing:

- (a) 2000 g of non-fissile material for every 1 g of fissile nuclides provided a homogeneity specification for the material is met;
- (b) 200 g of non-fissile material for every 1 g of fissile nuclides plus a package limit of 15 g of fissile nuclides.

Initially, these provisions were considered for inclusion in the Transport Regulations. However, consensus could not be reached on the precise wording of how to specify the distribution of fissile to non-fissile material.

A safety case for these exceptions was carried out [7]. Consignors might claim similar exceptions [8] within individual Member States, subject to multilateral approval of the material in accordance with the requirements of para. 606. The safety analysis substantiating the application for multilateral approval should include:

- (a) The same information as in para. 606.3;
- (b) Whether the safety case in Ref. [7] is sufficient or whether further assessment is required to satisfy the competent authority that the exception will provide adequate safety.

606.8. It may be possible to take into account the limited volume or mass of fissile material in a package, provided that it is far less than the quantity required for criticality; this is consistent with provisions, such as in para. 417(b), which have been in the Transport Regulations for a long time. Subcriticality of an unlimited quantity of uranyl nitrate solution applies to the case of full crystallization of the uranyl nitrate, but not if chemical conversion to oxide forms is possible. A sequence involving the conversion of a very large volume of solution from a single tank in a 30 min fire, the subsequent mixing with water and then the collection in a critical configuration has been considered too unlikely, even if theoretically possible. It is understood that there needs to be a minimum volume to prevent such a scenario. Also, very small volumes per package may be considered subcritical in practice if the materials in many

thousands of packages need to be converted, mixed with water and assembled to a critical configuration. For a new provision, a range of volumes or fissile nuclide masses could be specifically prohibited. Similar reasoned arguments may be used to support approval of a different material. Multilateral approval ensures adequate safety.

606.9. The effect of packaging may be credited if its presence can be guaranteed. For example, the transport of a fissile material, with a $k_{\infty} < 1$, but containing more than a few grams of plutonium per package would require a Type B(U) or Type B(M) package for reasons of radiological safety. It would be permissible to take account of the general performance of Type B(U) or Type B(M) packages under normal and accident conditions in the assessment of this material.

606.10. A specific reason for adding this provision to the Transport Regulations was that local conditions in a country, region or type of facility can be taken into account. One example is that where the source of a waste stream is well understood, the verification requirements can be adapted to that particular application and known properties of the actual fissile and other materials can be taken into account.

GENERAL REQUIREMENTS FOR ALL PACKAGINGS AND PACKAGES

607.1. The design of a package with respect to the manner in which it is secured (retained) within or on the conveyance considers only routine conditions of transport (see para. 613).

607.2. For additional guidance on the methods of retaining a package within or on a conveyance, see paras 564.1 and 564.2 and Appendix IV.

608.1. In the selection of materials for lifting attachments, consideration should be given to materials that will not yield under the range of loads expected in normal handling. If overloading occurs, then the safety of the package should not be affected. In addition, the effects of wear should be considered. It is considered good practice to test the lifting points before the packaging enters into service and then to control the lifting points during maintenance.

608.2. For the design of attachment points of packages lifted many times during their lifetime, the fatigue behaviour should be taken into account in order to avoid failure cracks. Where fatigue failure may be assumed, the design should take into account the detectability of those cracks by non-destructive means and appropriate tests should be included in the maintenance programme for the package.

608.3. Acceleration load factors (commonly called 'snatch factors' by rigging and handling personnel) for lifting by cranes should be identified in relation to the anticipated lifting characteristics of the cranes expected to be involved in these activities. In addition to these acceleration load factors, designers should also apply acceptable design safety factors [9–11] to structural yield parameters, ensuring that there is no plastic deformation in any part of the package during crane lifts.

608.4. Special attention should be given to lifting attachments of packages handled in nuclear facilities. In addition to damage to the package itself, the dropping of heavy, robust packages on to sensitive areas could result in releases of radioactive material from other sources within the facility or in a criticality accident or other event that could affect the safety of the facility. For these attachment points, even higher safety margins may be required than for normal engineering practice [9–11].

609.1. This requirement is intended to prevent inadvertent use of package features that are not suitably designed for handling operations.

610.1. This requirement is imposed since protruding features on the exterior of a packaging are vulnerable to impacts during handling and other operations incidental to transport. Such impacts may cause high stresses in the structure of the packaging, resulting in damage to the containment system.

610.2. In determining what is practicable as regards the design and finish of packaging, the primary consideration should be to not detract from the effectiveness of any features that are necessary for compliance with other requirements of the Transport Regulations. For example, features provided for safe handling, operation and stowage should be designed so that, while they fulfil their essential functions under the appropriate requirements of the Transport Regulations, any protrusions and potential difficulties of decontamination are minimized.

610.3. Cost is also a legitimate determinant of what is practicable. Measures to comply with para. 610 need not involve undue or unreasonable expense. For example, the choice of materials and methods of construction for any given packaging should be guided by commonly accepted good engineering practice for that type of packaging, having due regard to para. 610, and the need not invoke extravagantly expensive measures.

610.4. An exterior surface with a smooth finish having low porosity aids decontamination and is inherently less susceptible to absorption of contaminants and subsequent leaching out ('hide out') than a surface with a rougher finish.

610.5. Where it is impractical to design a package so that it can be easily decontaminated, other measures ('cleanliness processes') to prevent contamination should be included as part of the safety case for the package design. These measures may need to be approved by the competent authority and may be taken into account in the operating instructions for the package design. Appropriate management system measures should also be considered.

611.1. This requirement is imposed because collection and retention of water (from rain or other sources) on the exterior of a package might undermine the integrity of the package as a result of rusting or prolonged soaking. Furthermore, such retained liquid may leach out any surface contaminants present and spread them to the environment. Finally, water dripping from the package surfaces, such as rainwater, may be misinterpreted as leakage from the package.

611.2. For the purposes of compliance with para. 611, considerations analogous to those in paras 610.2–610.4 should be applied.

612.1. This requirement is intended to prevent actions such as placing handling tools, auxiliary equipment, transport frames or spare parts on or near the package in any manner such that the intended functions of packaging components could be impaired either during normal transport or in the event of an accident.

613.1. Components of a packaging, including those associated with the containment system, lifting attachments and retention systems, might become loose as a result of acceleration, vibration or vibration resonance. Attention should be paid in the package design to ensure that any nuts, bolts and other retention devices remain secure during routine conditions of transport.

613.2. In the case of freight containers used as industrial packages to transport heavy contents, it is essential to design the container, and the packing or tie-down system of the contents within the container, for the accelerations encountered in routine conditions of transport. This is to prevent the movement of the contents and thereby prevent damage to the container that could compromise the containment or shielding integrity of the industrial package.

613A.1 Packaging components and package contents are subjected to degradation mechanisms and ageing processes that depend on the component and the contents themselves and their operational conditions. Thus, the design of a package should take into account ageing mechanisms commensurate with intended use of the package and its operational conditions, as described in paras 613A.2-613A.6. The designer of a package should evaluate the potential degradation phenomena over time, such as corrosion, abrasion, fatigue, crack propagation, changes of material compositions or mechanical properties due to thermal loadings or radiation, generation of decomposition gases, and the impact of these phenomena on performance of safety functions.

613A.2 For packagings used once for a single transport and not intended for shipment after storage, inspection prior to use may be sufficient. Such packages may include excepted packages, Type IP-1, Type IP-2, Type IP-3 and Type A packages (e.g. fibreboard boxes, drums). If such packages involve shipment after storage, para. 613A.4 should be considered.

613A.3 For packagings intended for repeated use, the effects of ageing mechanisms on the package should be evaluated during the design phase in the demonstration of compliance with the Transport Regulations. Based on this evaluation, an inspection and maintenance programme should be developed. The programme should be structured so that the assumptions (e.g. thickness of containment wall, leak tightness, neutron absorber effectiveness) used in the demonstration of compliance of the package are confirmed to be valid through the lifetime of the packaging. An example of a procedure to prepare an ageing management programme for Type B(U) packages is provided in Ref. [12].

613A.4 In the design of packages intended to be used for shipment after storage, consideration of ageing mechanisms is important due to the long period between loading and the end of shipment after storage, the conditions of storage (even though the Transport Regulations do not apply to the storage of the package), and the difficulties in the inspection (to detect ageing effects) and maintenance of packages loaded with radioactive material. Furthermore, factors such as new technical knowledge, changes of package design, new requirements in the Transport Regulations applicable to package design or new technology for the identification and assessment of ageing effects should be recognized.

613A.5 With regard to package design, the consideration of the impact of ageing on the package as described in 613A.1 should be supported by an ageing management programme. This programme should address ageing effects, including prevention, mitigation, condition monitoring, and performance monitoring (see Ref. [13]) to justify the design considerations on ageing mechanisms. The programme should also include a gap analysis programme (see paras 809.3 and 809.4) to consider changes in technical knowledge, the state of package design and the requirements of the Transport Regulations. In particular, the ageing management programme should take into account the duration and conditions of storage as specified by the designer, as well as any monitoring, inspection and maintenance scheduled during storage and after storage before shipment. An ageing management programme and gap analysis programme should be developed for all designs of packages intended to be used for shipment after storage. For designs of Type B(U), B(M) and Type C packages these programmes are required to be included in the application for approval of packages for shipment after storage (see paras 809(f) and 809(k) of the Transport Regulations). The results of the ageing management programme and the gap analysis programme should be taken into account when preparing an inspection plan prior to transport.

613A.6 For UF₆ cylinders maintained and inspected in accordance with ISO 7195 [14] or ANSI N14.1 [15], no further evaluation of the potential degradation or ageing mechanism is required.

614.1. Consideration of the chemical compatibility of the radioactive contents with packaging materials and between different materials of the components of the packagings should take into account such effects as corrosion, embrittlement, accelerated ageing and dissolution of elastomers and elastics,

contamination with dissolved material, initiation of polymerization, gases produced by pyrolysis and alterations of a chemical nature.

614.2. Compatibility considerations should include those materials that may be left from manufacturing, cleaning or maintaining the packaging, such as cleaning agents, grease and oil, and should also include any residues from former contents of the package.

614.3. Consideration of physical compatibility should take into account the thermal expansion of materials and radioactive contents over the temperature range of concern so as to cover the changes in dimensions, hardness, physical states of materials and radioactive contents.

614.4. One aspect of physical compatibility is observed in the case of liquid contents, where sufficient ullage is required to be provided to avoid hydraulic failure as a consequence of the different expansion rates of the contents and its containment systems within the admissible temperature range. Void volume values to provide sufficient ullage may be derived from regulations for the transport of other dangerous goods with comparable properties.

615.1. Locks are probably one of the best methods of preventing unauthorized operation of valves; they can be used directly to lock the valve closed or can be used on a lid or cover that prevents access to the valve. Whilst seals can be used to indicate that the valve has not been used, they cannot be relied upon to prevent unauthorized operation.

616.1. An ambient pressure range of 60–101 kPa and an ambient temperature range of -40°C to 38°C are generally acceptable for surface modes of transport. For surface movements of excepted package(s), industrial package Types IP-1, IP-2 and IP-3, and Type B(M) packages solely within a specified country or solely between specified countries, ambient temperature and pressure conditions other than these may be assumed providing they can be justified and that adequate controls are in place to limit the use of the package(s) to the countries concerned.

617.1. The intention of the para. 617 is to demonstrate by calculation or other methods that the package is correctly designed to transport the maximum permitted contents without exceeding the dose rate limits specified in the Transport Regulations.

617.2. See para. 527.2.

ADDITIONAL REQUIREMENTS FOR PACKAGES TRANSPORTED BY AIR

619.1. Surface temperature restrictions are necessary to protect adjacent cargo from potential damage and to protect persons handling packages during loading and unloading. This requirement is particularly restrictive for transport by air as a result of the difficulty of providing adequate free space around packages. For this reason, para. 619 always applies to transport by air, whereas for other modes of transport, less restrictive surface temperature limits may be applied under the conditions of exclusive use (see paras 654 and 655 of the Transport Regulations and paras 654.1–654.3 and 655.1–655.3). If, during transport, the ambient temperature exceeds 38°C under extreme conditions (e.g. para. 620), the limit on accessible surface temperature no longer applies.

619.2. Account may be taken of barriers or screens intended to give protection to persons without the need for the barriers or screens being subject to any test.

620.1. The ambient temperature range of -40°C to 55°C covers the extremes expected to be encountered during air transport and is the range required by the ICAO [16] for packaging any dangerous goods, other than ‘dangerous goods in excepted quantities’, destined for air transport.

620.2. In designing the containment, the effect of ambient temperature extremes on resultant surface temperatures, contents, thermal stresses and pressure variations should be considered to ensure containment of the radioactive material.

621.1. This is a similar requirements to that in ICAO [16] for packages containing certain liquid dangerous goods intended for transport by air. In the 1996 Edition of the Transport Regulations, the requirement for the package to withstand a pressure differential of 95 kPa without loss or dispersal of radioactive contents was expanded to include all forms of radioactive material.

621.2. Pressure reductions due to altitude will be encountered during flight (see para. 578.1). The pressure differential that occurs at an increased altitude should be taken into account in the packaging design. The pressure differential of 95 kPa plus the MNOP (see paras 229.1–229.3) is the pressure differential to be accommodated by the package design, without loss or dispersal of radioactive contents from the containment system. This design specification results from a consideration of aircraft depressurization at a maximum civil aviation flight altitude together with any pressure already inside the package, with a safety margin. In the case of solid material, to comply with para. 621, means other than pressure resistance may be used to demonstrate compliance. If it can be demonstrated that there is no loss or dispersal of the radioactive contents from the containment system when the package is exposed to the pressure differential expected during flight, the package design can be considered to meet the requirement even if the internal pressure is not maintained. The following information about pressure variations should be considered when evaluating the pressure differential:

- (a) In normal flight conditions, the decrease in pressure in the cabin and cargo compartments of a pressurized aircraft may reach 150 Pa/s (2500 ft/min) during climbing, and the increase in pressure may reach 90 Pa/s (1500 ft/min) during descent of the aircraft;
- (b) Cargo-only aircraft may be designed and operated such that the cargo compartment is not pressurized during flight: for these types of aircraft the normal rate of pressure change experienced by the cargo is the actual rate associated with the climb and descent of the aircraft;
- (c) In normal flight conditions, the pressure in the cabin and cargo compartments of an aircraft may decrease from the atmospheric pressure at sea level (about 100 kPa) to 75 kPa in a pressurized aircraft and to 25 kPa in a non-pressurized aircraft;
- (d) In the event of an emergency, the pressure in the cabin and cargo compartments of a pressurized aircraft may drop suddenly to the pressure existing outside the aircraft (rapid decompression): in these emergency flight conditions it is considered that the cabin and cargo compartment pressure may drop linearly from a minimum normal equivalent altitude of 6000 ft, i.e. a maximum normal pressure of 81 kPa in cruise flight, to the standard ambient pressure of 15 kPa at 45000 ft altitude in a duration of 1 s.

621.3. If, within the definition of MNOP, the phrase “conditions of temperature and solar radiation corresponding to environmental conditions” is interpreted to include consideration of conditions specific to air transport (para. 620), then the MNOP does provide a suitable basis for specifying this requirement. If the temperature range given in para. 620 (–40°C to 55°C) is used, self-heating of the package contents is taken into account and the solar radiation input is considered to be zero, as the package is inside an aircraft, and hence the MNOP is consistent with the ICAO approach.

REQUIREMENTS FOR INDUSTRIAL PACKAGES

Requirements for industrial package Type 1 (Type IP-1)

623.1. The three industrial package types have different safety functions, as they are designed for different categories of LSA material and SCO. Whereas Type IP-1 packages simply contain their radioactive contents under routine transport conditions, Type IP-2 packages and Type IP-3 packages

protect against loss or dispersal of their contents and increase in dose rate (see paras 624.4–624.8) under normal conditions of transport, which, by definition (see para. 106), include minor mishaps, as far as the test requirements represent these conditions. Type IP-3 packages, in addition, provide the same package integrity as a Type A package intended to carry solids.

623.2. Neither the industrial package design requirements of the Transport Regulations nor the United Nations packing group III design requirements regard packages as pressure vessels. Under the United Nations recommendations [17], only those pressure vessels that have a volume of less than 450 L (in the case of liquid contents) or of less than 1000 L (in the case of gaseous contents) can be considered packages. Pressure vessels with greater volumes are defined as tanks, for which paras 627 and 628 provide a comparable level of safety. If pressure vessels are used as industrial packages, the design principles of relevant codes for pressure vessel should be taken into account in the selection of materials, design rules and calculation methods, and in the management system requirements for the manufacture and use of the package (e.g. pressure testing by independent inspectors). The comparably greater wall thickness of pressure vessels is usually foreseen as providing safety with respect to internal pressure (service conditions and test pressure). A design pressure higher than that needed to cover service conditions, and which corresponds to the vapour pressure at the upper temperature limit may provide a margin of safety against mishaps or even accidents by necessitating a greater thickness of wall. In this case, it may not be necessary to prove safety by drop and stacking performance tests, but rather by the pressure test. However, the safety of associated service equipment (e.g. valves) against mechanical loads needs to be ensured, for example, by the use of additional protective structures.

623.3. Pressure vessels with volumes of less than 450 L for liquid contents or less than 1000 L for gaseous contents, and designed for a pressure of 265 kPa (see para. 627(b)) may provide an adequate level of safety and, consequently, may not need to be subjected to the Type IP tests. It is understood that all precautions specified by the relevant pressure vessel codes for the use of pressure vessels are taken into consideration and applied as appropriate.

623.4. An example of this application is the pressure vessels used for the transport of uranium hexafluoride. These cylinders are designed for a pressure much higher than that occurring under normal transport and service conditions. They are therefore inherently protected against mechanical loads.

623.5. The ullage requirement (see para. 649) is not specified for industrial packages. However, in the case of liquid contents (or solid contents, such as uranium hexafluoride, which may become liquid in the event of heating), sufficient ullage should be provided, as referred to in para. 649, in order to prevent rupture of the containment. Such a rupture can occur in the case of insufficient ullage, especially as a result of expansion of the contents due to temperature change.

Requirements for industrial package Type 2 (Type IP-2)

624.1. See para. 623.1.

624.2. Consideration of the release of contents from Type IP-2 packages imposes a containment function on the package for normal conditions of transport. Some simplification in demonstrating no loss or dispersal of contents is possible owing to the rather immobile character of some LSA material and SCO contents and the limited specific activity and surface contamination. (See paras 648.2–648.5.)

624.3. For a Type IP-2 packaging intended to carry a liquid, see paras 623.2–623.5. For a Type IP-2 packaging intended to carry a gas, see paras 623.2–623.4. For a Type IP-2 packaging intended to carry LSA-III material, see para. 409.5.

624.4. The 20% limit on dose rate increase under normal conditions of transport is a design requirement to verify appropriateness of the shielding design. Compliance with this requirement could be demonstrated by shielding analysis, simulating deformation of the package and, as appropriate, movement of the radioactive contents and change in the state of the contents, including segregation and/or precipitation of the radionuclides due to normal conditions of transport. Dose rate increase due to a change in the state of the contents and/or movement of the contents under routine conditions of transport should be considered in the design of the package and in the preparation of the package for shipment (See paras 527.1, 528.1 and 573.1). Consequently, a dose rate increase due to these causes may be excluded from the demonstration of the dose rate increase under normal conditions of transport.

Requirements for industrial package Type 3 (Type IP-3)

625.1. See para. 623.1.

625.2. Consideration of the release of contents from Type IP-3 packages imposes the same containment function on Type IP-3 packages as for Type A packages for solids, with account taken of the higher values of specific activity that may be transported in Type IP-3 packages and the absence of operational controls in non-exclusive use transport. In the case of liquid LSA material, sufficient ullage should be provided in order to avoid hydraulic failure of the containment system. These requirements are consistent with the graded approach of the Transport Regulations. (See paras 648.2–648.5.)

625.3. For a Type IP-3 package intended to carry a liquid, see paras 623.2–623.5. For a Type IP-3 package intended to carry a gas, see paras 623.2–623.4. For a Type IP-3 package intended to carry LSA-III material, see para. 409.6.

Alternative requirements for industrial package Types 2 and 3 (Type IP-2 and Type IP-3)

626.1. The alternative use of United Nations packagings is allowed because the United Nations Recommendations on the Transport of Dangerous Goods, Model Regulations ('United Nations Recommendations') [17] require comparable general design requirements and performance tests that have been judged to provide the same level of safety. Whereas leaktightness is also one of the performance test criteria in the United Nations Recommendations, this is not the case with respect to the shielding requirements in the Transport Regulations, which need special attention when United Nations packagings are used.

626.2. As United Nations packing groups I and II require the same or even more stringent performance test standards compared with those for Type IP-2 packages, Type IP-2 test requirements are automatically complied with by all the United Nations packing groups I and II, except as stated in para. 626.3. This means that packagings marked with X or Y in accordance with the United Nations system are potentially suitable for the transport of LSA material and SCO requiring a Type IP-2 package when no specific shielding is required. For these packages, there should be consistency between the contents being shipped and the contents tested in the United Nations tests, including consideration of maximum relative density, gross mass, maximum total pressure, vapour pressure and the form of the contents.

626.3. United Nations packagings of packing groups I and II (i.e. packagings that meet the specifications given in Chapter 6.1 of the United Nations Recommendations [17]) may be used as Type IP-2 packages provided there is no loss or dispersal of the contents during or after the United Nations tests. It should be noted, however, that a slight discharge from the closure upon impact is permitted under the United Nations standard if no further leakage occurs. This discharge would not meet the requirement for no loss or dispersal of the contents. In addition, the intended contents should be consistent with those allowable in the particular packaging and specific shielding should not be required. The applicable

restrictions can be determined from the United Nations marking that is required on United Nations specification packagings.

626.4. See para. 648.4 for examples of methods that can be used to check compliance with para. 626(c)(i).

627.1. Portable tanks designed for the transport of dangerous goods in accordance with international and national regulations have proven to be safe in handling and transport, in some cases even under severe accident conditions.

627.2. The general design criteria for portable tanks with respect to safe handling, stacking and transport can be complied with if the structural equipment (frame) is designed in accordance with ISO 1496-3 [18]. ISO 1496-3 [18] prescribes a structural framework in which the tank is attached in such a manner that all static forces of handling, stowage and transport produce no undue stresses on the shell of the tank.

627.3. The dynamic forces under routine conditions of transport are considered in Appendix IV.

627.4. For radioactive material (without other dangerous properties), portable tanks designed in accordance with ISO 1496-3 [18] are considered to be at least equivalent to those that are designed to the standards prescribed in Chapter 6.7 of the Recommendations on Multimodal Tank Transport of the United Nations Recommendations [17].

627.5. The shielding retention requirement is complied with if, after the tests, the shielding material remains in place, shows no significant cracks and permits no more than a 20% increase in the dose rate as evaluated by calculation and/or measurement under the conditions described in para. 627(c). In the case of portable tanks with an ISO framework, the dose rate calculations/measurements may take the surfaces of the framework as the relevant surfaces. (See paras 624.4–624.8.)

628.1. To explain the equivalence between the requirements in para. 627 for portable tanks (relating to United Nations recommendations [17], Chapter 6.7), and other design standards established for tanks, reference should be made to the European Agreement Concerning the International Carriage of Dangerous Goods by Road (ADR) [19] and to the Regulations for the International Carriage of Dangerous Goods by Rail (RID) [20], where the same standards have been introduced in a corresponding Chapter 6.7, but where equivalent standards for road tank vehicles, rail tank wagons and tank containers have been introduced separately in Chapter 6.8, which specifies an acceptable equivalent safety level.

629.1. Freight containers designed and tested to ISO 1496-1 [21] and approved in accordance with the CSC Convention [22] have been proven, through the use of millions of units, to provide safe handling and transport under routine conditions of transport. It should be noted, however, that ISO 1496-1 addresses issues relating to container design and testing whereas the CSC Convention is primarily concerned with ensuring that containers are safe for transport, are adequately maintained and are suitable for international shipment by all modes of surface transport. The testing prescribed in CSC is not equivalent to that prescribed in ISO 1496-1.

629.2. Freight containers designed and tested to ISO 1496-1 [21] are restricted to the carriage of solids because they are not regarded as being suitable for free liquids or liquids in non-qualified packagings. Consideration should be given to the construction details of the container to ensure that the containment requirements of the Transport Regulations can be met. For example, welded joints are easier to leakage test if they are visible. Only closed types of freight container can be used to demonstrate compliance

with the Type IP-2 and Type IP-3 containment requirement of no loss or dispersal of radioactive contents, and monitoring during and after testing is necessary to demonstrate this.

629.3. Freight containers should be shown to retain and contain their contents during accelerations occurring in routine transport because the ISO standard tests for freight containers do not include dynamic tests. In practice, this may require demonstration of containment at the following stages, taking into account the contents to be transported:

- (a) Prototype testing in accordance with ISO 1496-1 [21] (before application of test loads, when the container is statically loaded, and when the test loads have been removed);
- (b) Production of each unit;
- (c) Maintenance;
- (d) Repair.

629.4. Care should be taken to ensure that attachments used within the container to secure objects can withstand loads typical of routine conditions of transport (see Appendix IV).

629.5. For guidance on preventing the loss or dispersal of contents and an increase in maximum surface dose rates, see paras 624.1–624.8.

630.1. Intermediate bulk containers approved in accordance with the provisions of Chapter 6.5 of the United Nations Recommendations [17] are considered to be equivalent to packages designed and tested in accordance with the Type IP-2 and Type IP-3 requirements, except with regard to any shielding requirements. The alternative use of intermediate bulk containers is restricted to metal designs only because they provide the closest match with Type IP-2 and Type IP-3 package requirements. The need for other design types could not be identified and they do not seem to be appropriate for the transport of radioactive material.

630.2. Compliance with the Type IP-2 and Type IP-3 design and performance test requirements may, with the exception of any shielding requirement, be demonstrated for intermediate bulk containers when they conform to the provisions of the United Nations Recommendations [17], Chapter 6.5, with the additional requirement for intermediate bulk containers with more than 0.45 m³ capacity to perform the drop test in the most damaging position (and not only on to the base). These recommendations include comparable design and performance test requirements as well as the design approval by the competent authority.

REQUIREMENTS FOR PACKAGES CONTAINING URANIUM HEXAFLUORIDE

631.1. Uranium hexafluoride is a radioactive material having a significant chemical hazard; however, the United Nations Recommendations require that the radioactive nature of the substance take precedence and the chemical hazard be considered as a subsidiary hazard [17]. Depending on the degree of enrichment and amount of fissile uranium present, uranium hexafluoride may be transported (i.e. in terms of the radiological hazard), in excepted, industrial, Type A, Type B(U) or Type B(M) packages. However, many of the requirements for the transport of uranium hexafluoride in both ISO 7195 [14] and the Transport Regulations do not relate to the radiological and criticality hazards posed by uranium hexafluoride, but to the physical properties and also to the chemical hazard of the material when released to the atmosphere and reacted with water or water vapour. In addition, since these packagings are pressurized during loading and unloading operations, they have to comply with pressure vessel regulations, although they are not pressurized under normal transport conditions. The requirements

specified in paras 631–634 of the Transport Regulations are focused on these concerns and not on radiological and criticality hazards. Other applicable requirements relating to the radiological and criticality hazards of the uranium hexafluoride being packaged and transported, are established elsewhere in the Transport Regulations, and compliance with these requirements is vital to providing proper safety during handling and transport.

631.2. Before ISO 7195 [14] was first published in 1993, ANSI N14.1 [15], was the uranium hexafluoride cylinder standard used throughout industry.. ISO 7195 was issued as an international alternative to ANSI N14.1, with no intent to develop or introduce new or additional provisions. Uranium hexafluoride cylinders manufactured, tested and maintained to ANSI N14.1 [15] can be considered to be in accordance with ISO 7195 [14] for the purpose of compliance with the Transport Regulations.

632.1. The 0.1 kg exemption level is based on consideration of the explosion of small, bare cylinders of uranium hexafluoride [23]. The 0.1 kg level is well below the mass limit of 10 kg, based on chemical hazards established in Refs [24, 25].

632.2. The acceptance criteria in para. 632(a)–(c) vary depending upon the type of environment to which the package is exposed. For the pressure test specific to uranium hexafluoride packages (para. 718), the requirement for acceptance without leakage and without unacceptable stress may be satisfied by hydrostatic testing of the cylinder, where leaks may be detected by seeking evidence of water leakage from the cylinder. The valve and other service equipment are not included in this pressure test (ISO 7195 [14]).

632.3. For the drop test (para. 722), acceptance may be demonstrated by performing a gas leakage test consistent with the procedure, pressure and sensitivity specified for valve leakage testing in ISO 7195 [14].

632.4. For the thermal test (para. 728), the criteria for acceptance during or following the test is based upon the need to prevent tearing of the cylinder shell. Tearing or major failure of the uranium hexafluoride cylinder walls would be unacceptable, but minor leakage through or around a valve or other engineered penetration into the cylinder wall might be acceptable subject to competent authority approval.

632.5. It may be difficult, if not impossible, to demonstrate compliance with the requirements of para. 632 by testing with uranium hexafluoride in the packagings because of major environmental, health and safety concerns. Thus, demonstration of compliance may need to depend upon tests in which surrogates for uranium hexafluoride are used, in combination with reference to previous satisfactory demonstrations, laboratory tests, calculations and reasoned arguments, as described in para. 701.

632.6. For demonstrating the compliance of packages containing uranium hexafluoride with the requirements of para. 632(c), the designer should take into account the influence of parameters that might alter the transient thermophysical conditions of uranium hexafluoride and/or the packaging under the conditions encountered in the thermal test. The designer should consider, as a minimum, the following:

- (a) The most severe orientation of the package: Changing the orientation of the package might produce a different distribution of the solid, liquid and gas phases of uranium hexafluoride inside the package and could lead to different consequences on internal pressure [26, 27].
- (b) The full range of allowed filling ratios: The pressure inside the cylinder could be dependent, in a complex fashion, upon the extent to which it is filled. For example, for very small filling ratios, the

solid uranium hexafluoride could melt and evaporate faster, thereby accelerating the pressure increase inside the package [28].

- (c) The actual properties of the structural materials at high temperatures: For example, a large reduction in the tensile strength of most steels occurs at temperatures above 500°C [29].
- (d) The presence of metallurgical defects in the structural material could cause the rupture of the package. This would be a function of the size of the defect. The maximum design defect size should be derived from design analyses, the manufacturing process and inspection acceptance criteria.

Thinning of the wall of the cylinder or other packaging components resulting from corrosion could result in reduced performance. The designer should establish a minimum acceptable wall thickness, and methods for determining wall thicknesses of in-service cylinders, both unfilled and filled, should be developed and applied [30, 31].

632.7. The tests specified in para. 632(b) and (c) may be carried out on separate packages.

633.1. This provision is included since it is unlikely that a pressure relief device can be provided that is sufficiently reliable to ensure a desired level of release and subsequent closure once the pressure reduces to acceptable levels.

634.1. Packages designed to carry 0.1 kg or more of uranium hexafluoride that are not designed to withstand the 2.76 MPa pressure test, but are designed to withstand a pressure test of at least 1.38 MPa, may be authorized for use, subject to approval by the competent authority. This is to allow older package designs, which can be demonstrated to the satisfaction of the competent authority as being safe, to be used, subject to multilateral approval. The package designer should prepare a safety case for justifying this certification.

634.2. Very large packages containing uranium hexafluoride, which are designed to contain 9000 kg or more of uranium hexafluoride and which are not transported in thermal protecting overpacks, have been considered as possibly having sufficient thermal mass to survive exposure to the thermal test in para. 728 without rupture of the containment system. Subject to approval of the competent authority, these packages may be certified for shipment on a multilateral basis, and the package designer should prepare a safety case for justifying this certification.

634.3. A graphical representation of the package design and approval requirements for uranium hexafluoride is shown in Fig. 4. In all cases, the other requirements pertaining to radioactive and fissile properties of the package contents apply.

634.4. See also para. 632.5.

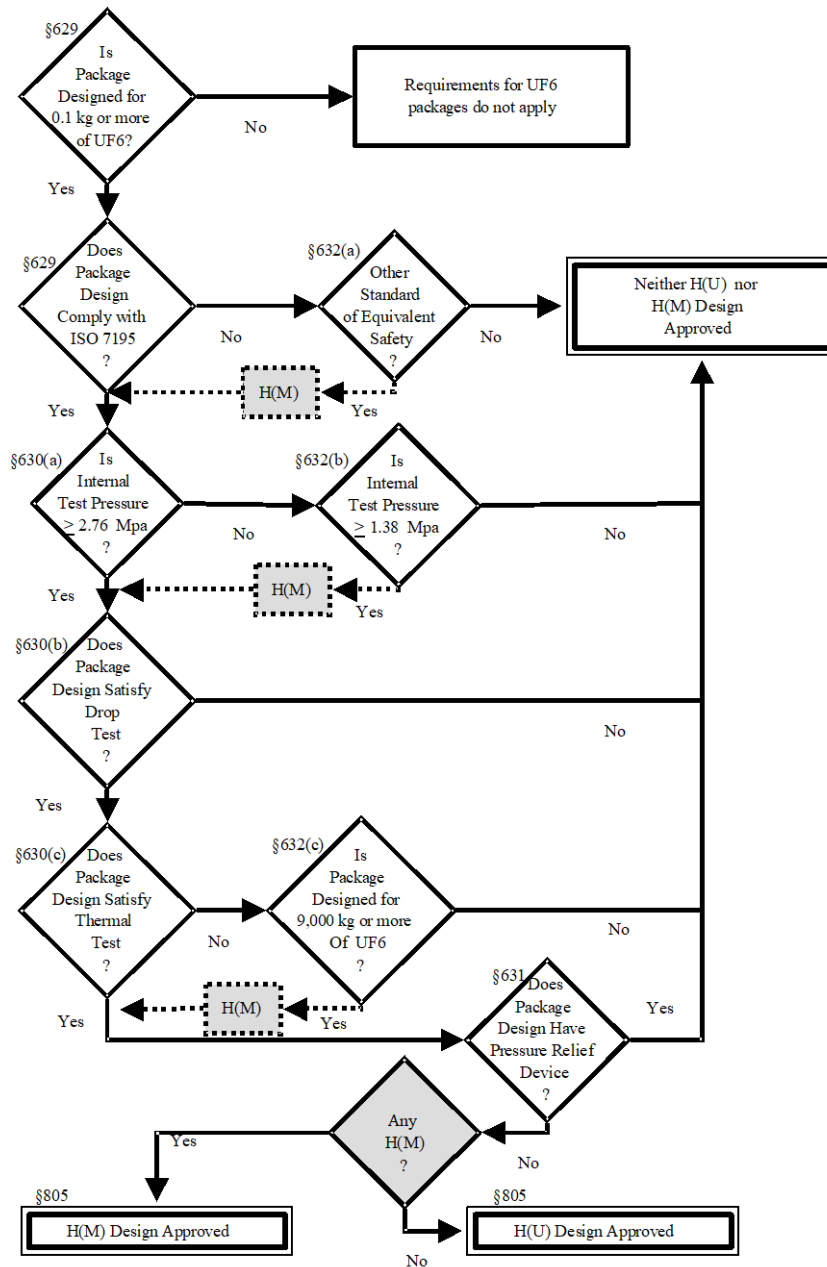

FIG. 4. Graphical representation of the additional package design and approval requirements for uranium hexafluoride.

REQUIREMENTS FOR TYPE A PACKAGES

636.1. The minimum dimension of 10 cm has been adopted for several reasons. A very small package could be mislaid or slipped into a pocket. To conform to international transport practice, package labels have to be 10 cm square. To display these labels adequately, the dimensions of the packages are required to be at least 10 cm.

637.1. Requiring a package seal is intended both to discourage tampering and to ensure that the recipient of the package knows whether or not the contents and/or the internal packaging have been tampered with or removed during transport. While the seal remains intact, the recipient is assured that the contents are those stated on the label; if the seal is damaged, the recipient will be warned that extra caution will be required during handling and particularly on opening the package.

637.2. The type of security seal to be used will mostly be determined by the type and mass of the package, but the designers should ensure that the type of seal is such that it will not be impaired during normal handling of the package in transport.

637.3. There are many methods of sealing but the following are typical of those used on packages for radioactive material:

- (a) When the packaging is a fibreboard carton, gummed or self-adhesive tape that cannot be reused to reseal the package may be used (i.e. the outer packaging and/or the tape should be effectively destroyed on being opened).
- (b) Crimped metal seals may be used on the closures of lead and steel pots, drums and small boxes. The seals are crimped on to the ends of a suitable lace or locking wire and are embossed with an identifying pattern. The method used to secure the closure itself should be independent of the security seal.
- (c) Padlocks may be used on timber boxes and also for steel and/or lead packages. A feature such as a drilled pillar may be incorporated into the box or packaging design so that when the padlock is fitted through the drilled hole it is not possible to open the package.

638.1. Except for tanks or freight containers used as packagings, the securing of packages that have a considerable mass relative to the mass of the conveyance will, in general, be accomplished using standard equipment suitable for restraining such large masses. Since the retention system “shall not impair” the functions of the package under normal and accident loading conditions it may be necessary to design the attachment of the retention system to the package so that it will fail first (commonly termed the ‘weak link’). This can be accomplished, for example, by designing the attachment point so that it will accommodate only a certain maximum size of shackle pin, or be held by pins that would shear, or bolts that would break, at a designated stress.

638.2. Lifting points may be used as retention system attachments, but if so used they should be designed specifically for both tasks. Separate lifting points and retention system attachments should be clearly marked to indicate their specific purposes, unless they can be so designed that alternative use is impossible, for example, a hook type of retention system attachment cannot normally be used for lifting purposes.

638.3. Consideration should also be given to potential directional failure of the retention systems so that transport workers are protected in the event of head-on impacts, while the package is protected against excessive side loads from side-on impacts [32]. For details on recommended design considerations of packages and their retention systems, see Appendix IV.

639.1. Type A package components are required to be designed for a temperature range of -40°C to 70°C , corresponding to possible ambient temperatures within a vehicle or other enclosure, or package temperatures when the package is exposed to direct sunlight. This range covers the conditions likely to be encountered in routine transport and storage in transit. If a wider environmental temperature range is likely to be encountered during transport or handling, or if there is significant internal heat generation, then this should be allowed for in the design. Some of the items that may need consideration are:

- (a) Expansion and contraction of components relative to structural or sealing functions;
- (b) Decomposition or changes of state of component materials in extreme conditions;
- (c) Tensile and ductile properties and package strength;
- (d) Shielding design.

640.1. Many national and international standards exist (e.g. Refs [3, 14, 18, 21, 33–36]), covering an extremely wide range of design influences and manufacturing techniques, such as pressure vessel codes, welding standards or leaktightness standards, which can be used in the design, manufacturing and testing of packages. Designers and manufacturers should, wherever possible, work to these established standards in order to promote and demonstrate adequate control in the overall design and manufacture of packages. The use of such standards also means that the design and manufacturing processes are more readily understood by all relevant individuals, sometimes in different locations and in different Member States, involved in the various phases of transport, and most importantly, package integrity is much less likely to be compromised.

640.2. Where new design, manufacturing or testing techniques are proposed for use and there is no appropriate existing standard, the designer may need to discuss the proposals with the competent authority to obtain acceptance. Consideration should be given by the designer, the competent authority or other responsible bodies to developing an acceptable standard covering any new design concept, manufacturing or testing technique, or material to be used.

641.1. Examples of positive fastening devices that may be suitable are:

- (a) Welded seams;
- (b) Screw threads;
- (c) Snap-fit lids;
- (d) Crimping;
- (e) Rolling;
- (f) Peening;
- (g) Heat shrunk materials;
- (h) Adhesive tapes or glues.

Other methods may be appropriate, depending on the package design.

642.1. Where special form radioactive material constitutes part of the containment system, consideration should be given to the appropriate performance of the special form material under the applicable routine, normal and accident conditions of transport.

644.1. Certain materials may react chemically or radiolytically with some of the substances intended to be carried in Type A packages. Tests may be required to determine the suitability of materials to ensure that the containment system is neither susceptible to deterioration caused by the reactions themselves nor damaged by the pressure increase consequent upon those reactions.

645.1. This requirement is intended to prevent a packaging failure caused by an excessive pressure differential arising in a package that has been filled at sea level (or below) and is then carried by surface transport to a higher altitude. This requirement is equivalent to air pressure variations resulting from surface movements to altitudes as high as 4000 m. If the package could be sealed at or below sea level and transported over land to this altitude, the package is required to withstand an overpressure resulting from this change in altitude as well as being able to withstand any overpressure that may be generated by its contents.

645.2. For guidance on the requirement for the retention of radioactive contents, see paras 648.2–648.5.

646.1. To prevent contamination caused by leakage of contents through valves, the Transport Regulations require a secondary device or enclosure for these valves. Depending upon the specific design, such a device or enclosure may also help to prevent the unauthorized operation of the valve (see para. 615 of the Transport Regulations).

646.2. Examples of enclosures that may be suitable are:

- (a) Blank caps on threaded valves using gaskets;
- (b) Blank flanges on flanged valves using gaskets;
- (c) Specially designed valve covers or enclosures, using gaskets, designed to retain any leakage.

Other methods may be appropriate, depending on the package design.

647.1. The requirement of para. 647 is primarily intended to ensure that the radiation shield is constantly maintained around the radioactive substance to minimize any increase in dose rates on the surface of the package. When the radiation shield is a separate unit, the positive fastening device ensures that the containment system is not released except by deliberate intent.

647.2. Examples of positive fastening devices that may be suitable are:

- (a) Hinge operated interlock devices on covers;
- (b) Bolted, welded or padlocked frames surrounding the radiation shield;
- (c) Threaded shielding plugs.

Other methods may be appropriate, depending on the package design.

648.1. The contents limits for Type A packages intrinsically limit the radiological hazard. This paragraph establishes additional requirements for package design, to ensure safety during normal conditions of transport.

648.2. A maximum allowable leakage rate for the normal transport of Type A packages has never been defined quantitatively in the Transport Regulations, but it has always been required in a practical sense.

648.3. Practically, it is difficult to advise on a single test method that could satisfactorily incorporate the existing vast array of packagings and their contents. A qualitative approach, dependent upon the packaging under consideration and its radioactive contents, may be employed. In applying the preferred test method, the maximum differential pressure used should be that resulting from the contents and the expected ambient conditions. The intent of paras 621, 624(a), 648(a) and 651 is to ensure that, under

normal transport conditions, the radioactive contents of the package cannot escape in quantities that may create a radiological or contamination hazard.

648.4. For solid, granular and liquid contents, one way of satisfying the requirements for 'no loss or dispersal' would be to monitor the package (containing a non-active, control material) on completion of a vacuum test or other appropriate tests to determine visually whether any of the contents have escaped. For liquids, an absorbent material may be used as a test indicator. Thereafter, a careful visual inspection of the package may confirm that its integrity is maintained and that no leakage has occurred. Another method that may be suitable in some cases would be to weigh the package before and after a vacuum test to determine whether any leakage has occurred.

648.5. For gaseous contents, visual monitoring is unlikely to be satisfactory and a suction detection or pressurization method with a readily identifiable gas (or volatile liquid providing a gaseous phase) may be used. Again, a careful visual inspection of the packaging may confirm that its integrity has been maintained and that no escape paths exist. Another detection method would be a simple bubble test.

648.6. For advice concerning the increase in maximum surface dose rates, see paras 624.4–624.8.

649.1. Ullage is the gas filled space available within the package intended to accommodate the expansion of the liquid contents of the package resulting from changes in environmental and transport conditions. Adequate ullage ensures that the containment system is not subjected to excessive pressure due to the expansion of liquid-only systems, which are generally regarded as incompressible.

649.2. When establishing ullage specifications, it may be necessary to consider both extremes of package material temperature, i.e. -40°C and 70°C (see para. 639). At the lower temperature, pressure increases may occur as a result of expansion at transitional temperatures where the material changes its state from liquid to solid. At the higher temperature, pressure increases may occur as a result of expansion or vaporization of the liquid contents. Consideration may also be needed to ensure that excessive ullage is not provided as this may allow unacceptable dynamic surges within the package during transport. In addition, surging or lapping may occur during filling operations involving large liquid quantities and designers may need to consider this aspect for certain package designs.

650.1. A user of a Type B(U) package, a Type B(M) package or a Type C package may wish to use that package for shipping less than an A_2 quantity of liquid and to designate this package in the shipping papers as a Type A package shipment. This lifts some administrative burdens from the consignor and carrier and, since the package has a greater integrity than a standard Type A package, safety is not degraded. In this case, there is no requirement to add absorbent material or a secondary outer containment component.

651.1. The reasons for additional tests for Type A packaging for compressed or uncompressed gases are similar to those for Type A packagings for liquids. However, since, in the case of gases, failure of the containment would always give 100% release, the additional test is required to reduce the probability of failure of the containment for a given severity of accident and thus achieve a level of risk comparable with that of a Type A package designed to carry dispersible solids.

651.2. The exception of packages containing tritium or noble gases from the requirement in para. 651 is based upon the dosimetric models for these materials (the Q system, see discussion in Appendix I).

651.3. For guidance on the requirement of no loss or dispersal of gaseous radioactive contents, see para. 648.5.

REQUIREMENTS FOR TYPE B(U) PACKAGES

652.1. The concept of a Type B(U) package is that it is capable of withstanding most of the severe accident conditions in transport without loss of containment or increase in external dose rate to an extent that would endanger the public or those involved in emergency response actions or remediation. It should be safely recoverable (see paras 509 and 510), but it would not necessarily be capable of being reused.

653.1. Although the requirement in para. 639, which is for Type A packages, is intended to cover most conditions that can result in packaging failure, additional consideration of packaging component temperatures is required for Type B(U) packages on a design specific basis. This is generally because Type B(U) packages may be designed for contents that produce significant amounts of heat, and component temperatures for such a design may exceed the 70°C requirement for Type A packages. The intent of specifying an ambient temperature of 38°C for package design considerations is to ensure that the designer properly addresses packaging component temperatures and the effect of these temperatures on geometry, shielding, efficiency, corrosion and surface temperature. Furthermore, the requirement that a package be capable of being left unattended for a period of one week at an ambient temperature of 38°C with solar heating is intended to ensure that the package will be at, or close to, equilibrium conditions and that under these conditions it will be capable of withstanding the normal transport conditions, demonstrated by the tests in paras 719–724, without loss of containment or reduction in radiation shielding.

653.2. The evaluation with respect to ambient temperature conditions has to take into account the heat generated by the contents, which may be such that the maximum temperature of some package components may be considerably in excess of the maximum of 70°C specified for a Type A package design.

653.3. See also paras 639.1, 655.1, 655.2, 657.1–657.9 and 666.1–666.3 and Appendix V.

653.4. Practical tests may be used to determine the internal and external temperatures of the package under normal conditions by simulating the heat due to radioactive decay of the contents using electrical heaters. In this way, the heat source can be controlled and measured. Such tests should be performed in a uniform and steady thermal environment (i.e. constant ambient temperature, still air and minimum heat input from external sources such as sunlight). The package, with its heat source, should be held under test for sufficient time to allow the temperatures of interest to reach steady state. The test ambient temperature and internal heat source should be measured and used to adjust, linearly, all measured package temperatures to those corresponding to a 38°C ambient temperature.

653.5. For tests performed in uncontrolled environments (e.g. outside), ambient variations (e.g. diurnal) may make it impossible to achieve constant steady state temperatures. In such cases, the periodic quasi-steady-state temperatures should be measured (both ambient and package), allowing correlations to be made between ambient and package average temperatures. These results, together with data on the internal heat source, can be used to predict package temperatures corresponding to a steady 38°C ambient temperature.

653.6 In some cases, national standards and/or the technical specification of the package contents define a maximum allowable temperature; these contents temperature limits should be adhered to.

654.1. The surface temperatures of packages containing heat generating radioactive material will rise above the ambient temperature. Surface temperature restrictions are necessary to protect adjacent cargo from potential damage and to protect persons handling packages during loading and unloading.

654.2. With a surface temperature limit of 50°C at the maximum ambient temperature of 38°C, other cargo will not become overheated nor will anyone handling or touching the surface suffer burns. A higher surface temperature is permitted under exclusive use (except for transport by air) (see para. 655 of the Transport Regulations and paras 655.1–655.3).

654.3. Insolation may be ignored with regard to the temperature of accessible surfaces and account is taken only of the internal heat load. The justification for this simplification is that any package, with or without internal heat, would experience a similar surface temperature increase when subjected to insolation.

655.1. The surface temperature limit of 85°C for Type B(U) packages under exclusive use, where potential damage to adjacent cargo can be well controlled, is required to prevent injury to persons from casual contact with packages. The barriers or screens referred to in para. 655 are not regarded as part of the package; therefore, they are excluded from any tests associated with the package design.

655.2. Readily accessible surface is not a precise description, but is interpreted here to mean those surfaces that could be casually contacted by a person who may not be associated with the transport operation. For example, the use of a ladder might make surfaces accessible, but this would not be cause for considering the surfaces as readily accessible. In the same sense, surfaces between closely spaced fins would not be regarded as readily accessible. If fins are widely spaced, say the width of a person's hand or more, then the surface between the fins could be regarded as readily accessible.

655.3. Barriers or screens may be used to give protection against higher surface temperatures and still retain the Type B(U) approval category. An example would be a closely finned package fitted with lifting trunnions where the use of the trunnions would require the fins to be cut away locally to the trunnions and thus expose the main body of the package as an accessible surface. Protection may be achieved by using a barrier, such as an expanded metal screen or an enclosure that effectively prevents access or contact with the package by persons during routine transport. Such barriers would then be considered as accessible surfaces and would, thus, be subject to the applicable temperature limit. The use of barriers or screens should not impair the ability of the package to meet heat transfer requirements nor reduce its safety.

656.1. See para. 666.1.

657.1. During transport, a package could be subjected to solar heating. The effect of solar heating is to increase the package temperature. To avoid the difficulties in trying to take into account the many variables precisely, values for insolation have been agreed upon internationally (see Table 12 of the Transport Regulations). The insolation values are specified as uniform heat fluxes applied for 12 h and followed by 12 h of zero insolation. Packages are assumed to be in the open; therefore, neither shading nor reflection from adjacent structures is considered. Table 12 shows a maximum value for insolation for an upward facing horizontal surface and zero for a downward facing horizontal surface that receives no insolation. A vertical surface is assumed to be heated for only half a day and only half as effectively; therefore, the table value for insolation of a vertical surface is given as one quarter the maximum value for an upward facing flat surface. Locations on curved surfaces vary in orientation between horizontal and vertical and are judiciously assigned half the maximum value for upward facing horizontal surfaces. The use of these agreed values ensures uniformity in any safety assessment, providing a common basis for calculation.

657.2. The insolation data provided in Table 12 of the Transport Regulations are uniform heat fluxes. They are to be applied at the levels stated for 12 h (daylight) followed by 12 h of no insolation (night). The cyclic step functions representing insolation should be applied until the temperatures of interest reach conditions of steady periodic behaviour.

657.3. A simple but conservative approach for evaluating the effects of insolation is to apply uniform heat flux continuously at the values stated in Table 12 of the Transport Regulations. Use of this approach avoids the need to perform transient thermal analysis; only a simple steady state analysis is performed.

657.4. For a more precise model, a time dependent sinusoidal heat flux may be used to represent insolation during daylight hours for both flat and curved surfaces. The integrated (total) heat input to a surface between sunrise and sunset is required to be equal to the appropriate value of total heat for the table values over 12 h (i.e. multiply the table value by 12 h to obtain total heat input (in W/m^2)). The period between sunset and sunrise gives zero heat flux for this model. The cyclic insolation model should be applied until the temperatures of interest reach conditions of steady periodic behaviour.

657.5. Figure 5 shows a horizontal cross-section of a package with flat surfaces. Table 12 values apply as follows:

- (a) For any horizontally downward facing flat surface, which cannot receive any insolation (case 1), the Table 12 value of zero applies.
- (b) For any horizontally upward facing flat surface (case 2), the Table 12 value of $800 \text{ W}/\text{m}^2$ applies.
- (c) For any vertical flat surface (case 3, i.e. within 15° of the vertical) and for any downward tilted flat surface (case 4), the Table 12 value of $200 \text{ W}/\text{m}^2$ applies.
- (d) For any upward tilted flat surface (case 5, all other surfaces), the Table 12 value of $400 \text{ W}/\text{m}^2$ applies.

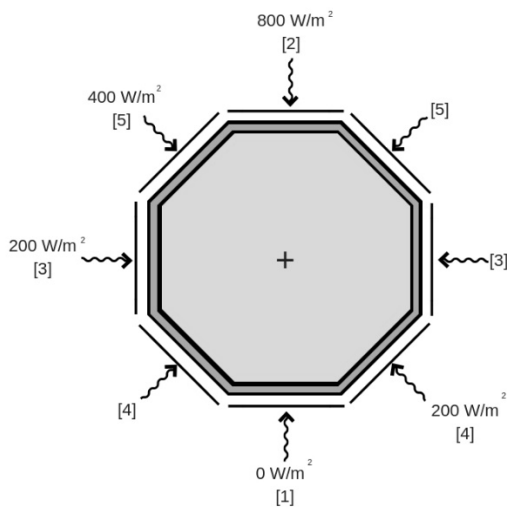

FIG. 5. Horizontal cross-section of package with flat surfaces ([1–5] denotes cases as shown in Table 12 of the Transport Regulations).

657.6. Figure 6 shows a vertical cross-section of a package with curved surfaces and flat vertical surfaces. Table 12 values apply as follows:

- (a) For any vertical flat surface (case 3, i.e. within 15° of the vertical), the Table 12 flat surfaces transported vertically value of $200 \text{ W}/\text{m}^2$ applies.
- (b) For any downward facing curved surfaces (case 4), the Table 12 other downward facing surface value of $200 \text{ W}/\text{m}^2$ applies.

(c) For any upward facing curved surfaces (case 5, all other surfaces), the Table 12 value of 400 W/m^2 applies.

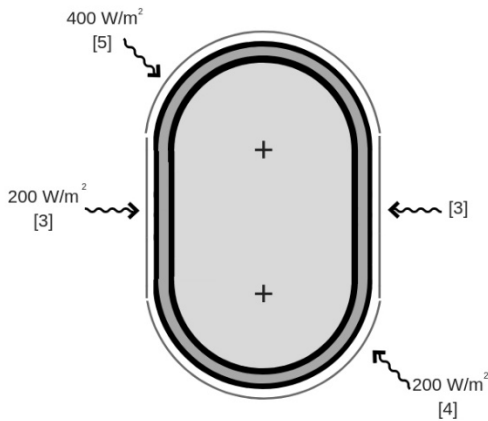

FIG. 6. Vertical cross-section of package with curved surfaces ([3–5] denotes cases as shown in Table 12 of the Transport Regulations).

657.7. Components of the package that reduce insolation to any surface (i.e. provide solar shade to the surface of the package) may be taken into account in the thermal evaluation. Any such components assumed to reduce insolation should not be included in the thermal evaluation if their effectiveness would be reduced as a result of the package being subjected to the tests for normal conditions of transport.

657.8. As radiation heat transfer depends on the emissivity and absorptivity at a surface, variations in these properties may be taken into account. These surface properties are wavelength dependent. Solar radiation corresponds to high temperature and short wavelength radiation while surface radiation from packages corresponds to relatively low temperature and longer wavelength radiation. In many cases, the absorptivity will be lower than the emissivity and therefore using the higher value for both will provide a greater margin of safety when the objective is heat dissipation. In other cases, advantage might be taken of naturally occurring differences in these properties, or the surface could be treated to take advantage of such differences to reduce the effect of insolation. When differences in surface properties are used as a means of thermal protection to reduce insolation effects, the performance of the thermal protection system should be demonstrated, and the system should be shown to remain intact under normal conditions of transport. Various sources of published data are available, listing specific properties for materials at particular temperature ranges, which provide realistic values for emissivity and absorptivity, e.g. Ref. [37].

657.9. Evaluation of the package temperature may be done by analysis or test. Tests, if used, should be performed on full scale models. If the radiation source is not sunlight, differences between solar wavelength and the source wavelength should be taken into account. The test should continue until thermal equilibrium is achieved (either constant steady state or steady periodic state, depending on the source). Corrections should be made for ambient temperatures and internal heat, where necessary.

658.1. In general, coatings for thermal protection fall into two groups: those that undergo a chemical change in the presence of heat (e.g. ablative and intumescent) and those that provide a fixed insulation barrier (including ceramic materials).

658.2. Both groups are susceptible to mechanical damage. Materials of the ablative and intumescent type are soft and can be damaged by sliding against rough surfaces (such as concrete or gravel) or by

the movement of hard objects against them. In contrast, ceramic materials are very hard, but are usually brittle and unable to absorb shock without cracking or fracturing.

658.3. Commonly occurring incidents that are not simulated by the tests required in paras 722–727 and that could cause damage to the thermal protection materials include: relative movement between the package and the contact surfaces of vehicle during transport; skidding across a road in which surface gravel is embedded; sliding over a damaged rail track or against the edge of a metal member; lifting or lowering against bolt heads of adjacent structures or equipment; impact of other packages (not necessarily containing radioactive material) during stowage or transport. Packages that are tested by a simple drop test do not receive damage to the surface that is the same as that received due to the rolling and sliding action usually associated with a vehicle accident, and packages subsequently thermally tested may have a coating that, under practical accident conditions, could be damaged.

658.4. Damage to a thermal protection coating may reduce the effectiveness of the coating, at least over part of the surface. The package designer should assess the effects of this kind of damage.

658.5. The effects of age and environmental conditions on thermal protection materials also need to be taken into account. The properties of some materials change with time, and with temperature, humidity or other conditions.

658.6. A coating may be protected by adding skids or buffers that would prevent other surfaces sliding or rubbing against the material. A durable outer skin of metal or an overpack may give good protection but could alter the thermal performance of the package. The external surface of the package may also be designed so that thermal protection can be applied within recesses.

658.7. With the agreement of the competent authority, thermal tests undertaken with arbitrary damage to the thermal protection materials of a package may be made to show the effectiveness of thermal protection even when these materials are damaged, where it can be shown that such damage will yield conservative test results.

659.1. The concept of specifying containment standards for large radioactive source packages in terms of activity loss in relation to specified test conditions was first introduced in the 1967 Edition of the Transport Regulations.

659.2. The release rate limit of not more than 10^{-6} A₂ per hour for Type B(U) packages following tests to demonstrate their ability to withstand the normal conditions of transport was originally derived from considerations of the most adverse expected conditions. This was taken to correspond to a worker exposed to radioactive material leaking from a package during its transport by road in an enclosed vehicle. The design principle embodied in the Transport Regulations is that radioactive release from a Type B(U) package should be avoided. However, since absolute containment cannot be guaranteed, the purpose of specifying maximum allowable ‘activity leak’ rates is to permit the specification of appropriate and practical test procedures that are related to acceptable radiological protection criteria. The model used in the derivation of the release rate of 10^{-6} A₂ per hour, as well as the special provisions in the case of Kr-85, are discussed in Appendix I.

659.3. The 1973 Revised Edition (As Amended) of the Transport Regulations stipulated that the dose rate at 1 m from the surface of a Type B(U) package should not exceed 100 times the value that existed before the accident condition tests, had the package contained a specified radionuclide. This requirement constituted an unrealistic design constraint in the case of packages designed to carry other radionuclides. Therefore, since the 1985 Edition of the Transport Regulations, a specific maximum dose rate of 10 mSv/h has been stipulated, irrespective of radionuclide.

659.4. The release limits of not more than $10A_2$ for Kr-85 and not more than A_2 for all other radionuclides within a period of one week for Type B(U) packages when subjected to the tests to simulate accident conditions of transport represent a simplification of the provisions of the 1973 Edition of the Transport Regulations. This change was introduced because the Type B(U) limit appeared unduly restrictive in comparison with safety criteria commonly applied at power reactor sites [38, 39], especially for severe accident conditions that are expected to occur only very infrequently. The radiological implications of a release of A_2 from a Type B(U) package under accident conditions have been discussed in detail elsewhere [40]. Assuming that accidents of the severity simulated in the Type B(U) tests would result in all persons in the immediate vicinity of the damaged package being rapidly evacuated, or else working under health physics supervision and control, the exposure of persons near the scene of the accident is unlikely to exceed the annual dose limits for workers set out in GSR Part 3 [41]. The special provision in the case of Kr-85, which is the only noble gas radionuclide of practical importance in shipments of irradiated nuclear fuel, results from a specific consideration of the dosimetric consequences of exposure to a radioactive plume, for which the models used in the derivation of A_2 values for non-gaseous radionuclides are inappropriate [42] (see also para. I-74).

659.5. The release limits in para. 659 of the Transport Regulations have the advantage of expressing the desired containment performance in terms of the parameter of primary interest, i.e. the potential hazard of the particular radionuclide in the package. The disadvantage of this method is that direct measurement is generally impractical, especially if it is required to be applied to each individual radionuclide in the physical and chemical forms that are expected after the mechanical, thermal and water immersion tests. It is more practical to use well established leakage testing methods such as gas leakage tests (see ANSI N14.5 [35] and ISO 12807 [36]). In general, leakage tests measure material flow passing a containment boundary. The flow may contain a tracer material such as a gas, liquid, powder or the actual or surrogate contents. A means should therefore be determined to correlate the measured flow with the leakage of radioactive material expected under the reference conditions. This leakage can then be compared with the maximum radioactive material leakage rate that is permitted by the Transport Regulations. If the tracer material is a gas, the leakage rate expressed as a mass flow rate can be determined. If the tracer material is a liquid, either the leakage rate, expressed as a volumetric flow rate, or the total leakage expressed as a volume can be determined. If the tracer material is a powder, the total leakage, expressed as a mass, can be determined. Finally, if the tracer material is radioactive, the leakage expressed as an activity can be determined. Volumetric flow rates for liquids and mass flow rates for gases can be calculated using established equations. If powder leakage is calculated by assuming that the powder behaves as a liquid or an aerosol, the result will be very conservative.

659.6. The basic calculation method for correlating the measured flow with the leakage of radioactive material involves the knowledge of two parameters, the radioactive concentration of the contents of the package and its volumetric leakage rate. The product of these two parameters should be less than the maximum permitted leakage rate expressed as a fraction of A_2 per unit time.

659.7. For packages containing radioactive material in liquid or gaseous form, the concentration of the radioactivity is determined in order to convert Bq/h (activity leakage rate) to m^3/s (volumetric leakage rate) under equivalent transport conditions. When the contents include mixtures of radionuclides (R1, R2, R3, RN, etc.), the 'unity rule' specified in para. 405 is used as follows:

$$\frac{\text{Potential release of R1}}{\text{Allowable release of R1}} + \frac{\text{Potential release of R2}}{\text{Allowable release of R2}} + \frac{\text{Potential release of RN}}{\text{Allowable release of RN}} \leq 1 \quad (2)$$

659.8. From this, and assuming uniform leakage rates over the time intervals being considered, the activity of the gas or liquid in the package and the volumetric leakage rate are required to fulfil the following conditions:

For the conditions in para. 659(a):

$$\sum_i \frac{C_{(R_i)}}{A_2(R_i)} \leq \frac{10^{-6}}{3600L} = \frac{2.78 \times 10^{-10}}{L} \quad (3)$$

For the conditions in para. 659(b)(ii):

$$\sum_i \frac{C_{(R_i)}}{A_2(R_i)} \leq \frac{1}{7 \times 24 \times 3600L} = \frac{1.65 \times 10^{-6}}{L} \quad (4)$$

where

$C(R_i)$ is the concentration of each radionuclide in TBq/m³ of liquid or gas at standard conditions of temperature and pressure (STP);

$A_2(R_i)$ is the limit specified in Table 2 of the Transport Regulations in TBq for that nuclide;

L is the permitted leakage rate in m³/s of liquid or gas at STP.

The quantity C can also be derived as follows:

$$C = GS$$

where

G is the concentration of the radionuclide in kg/m³ of liquid or gas at STP

S is the specific activity of the nuclide in TBq/kg of the pure nuclide (see Appendix II)

or

$$C = FgS$$

where

F is the fraction of the radionuclide present in an element (percentage/100)

g is the concentration of the element in kg/m³ of liquid or gas at STP.

659.9. It should be noted that the allowable activity release after tests for normal conditions of transport is given in terms of A_2 (TBq/h) and after tests for accident conditions in terms of A_2 (TBq/week). It is unlikely that any leakage after an accident will be at a uniform rate. The value of interest is the total leakage occurring during the week and not the rate at any time during the week (i.e. the package may leak at a high rate for a short period of time following exposure to the accident environment and then release essentially nothing for the remainder of the week as long as the total release does not exceed A_2 per week).

659.10. The calculated permitted leakage of radioactive liquid or gas may then be converted to an equivalent test gas leakage under reference conditions, taking account of pressure, temperature and viscosity by means of the equations for laminar and/or molecular flow conditions, examples of which are given in ANSI N14.5 [35] or ISO 12807 [36]. In cases where a high differential pressure may result in a high permitted gas velocity, turbulent flow may be the more limiting quantity and should be taken into account. The calculation should consider the reduced ambient pressure of 60 kPa in accordance with para. 645.

659.11. The test gas leakage determined by the above method may range from about $1 \text{ Pa}\cdot\text{m}^3\cdot\text{s}^{-1}$ to less than $10^{-10} \text{ Pa}\cdot\text{m}^3\cdot\text{s}^{-1}$, depending upon the A_2 values of the radionuclides and their concentration in the package. Generally, in practice, a test need not be more sensitive than $10^{-8} \text{ Pa}\cdot\text{m}^3\cdot\text{s}^{-1}$ for a pressure difference of $1 \times 10^5 \text{ Pa}$ to qualify a package as being leaktight. Where the estimated allowable test leakage rate exceeds $10^{-2} \text{ Pa}\cdot\text{m}^3\cdot\text{s}^{-1}$, a limiting value of $10^{-2} \text{ Pa}\cdot\text{m}^3\cdot\text{s}^{-1}$ is recommended because it is readily achievable in practical cases.

659.12. The containment system of the package design should be explicitly defined, including the containment boundary of the system. The definition of the containment system is provided in para. 213 of the Transport Regulations, and additional information is provided in paras 213.1–213.3. The containment boundary should consider features such as vent and drain ports and penetrations that could present a leakage path from the containment system. For package systems that have double or concentric seals, the containment system seal should be defined. Leakage testing of the package should address all containment system seals (i.e. main closure, vent and drain). The containment system should be composed of engineered features whose design is defined in the drawings of the packaging. The components of the containment system that are relied on to meet the requirements of para. 659 should be included in any physical tests or engineering evaluations performed for the package for normal conditions of transport and for accident conditions, as applicable. Handling items such as bags, boxes and cans that are used solely as product containers or to facilitate handling of the radioactive material should be considered in terms of their potential negative impact on package performance, including structural and thermal impacts.

659.13. When a package is designed to carry solid particulate material, test data on the movement of solids through discrete leakage paths or seals can be used to establish test gas conditions. This will generally give a higher allowed volumetric leakage rate than assuming the particulate material behaves as a liquid or an aerosol. In practice, even the smallest particle size powder would not be expected to leak through a seal that has been tested with helium to better than $10^{-6} \text{ Pa}\cdot\text{m}^3\cdot\text{s}^{-1}$ with a pressure difference of $1 \times 10^5 \text{ Pa}$.

659.14. In a package design, maximum dose rates are established both at the surfaces (paras 527 and 528) and at 1 m from the surfaces of the package (as implied by paras 523 and 526). After the tests for accident conditions have been performed, however, an increase in the dose rate is allowed provided that the limit of 10 mSv/h at 1 m from the surface is not exceeded when the package is loaded with its maximum allowed activity.

659.15. When shielding is required for a Type B(U) package design, the shielding may consist of a variety of materials, some of which may be lost during the tests for accident conditions. This is acceptable provided that the radioactive contents remain in the package and sufficient shielding is retained to ensure that the dose rate at 1 m from the ‘new’ (after test) external surface of the package does not exceed 10 mSv/h.

659.16. The demonstration of compliance with this acceptance criterion of not more than 10 mSv/h at 1 m from the external surface of a Type B(U) package after the applicable tests may be made by different means; for example, by calculations, tests on models, parts or components of the package, tests on

prototypes, or by a combination of these. In verifying compliance, attention should be paid to the potential for increased localized dose rates through cracks or gaps, which could appear as a defect of design or manufacturing or could occur during the tests as a consequence of the mechanical or thermal stresses, particularly in drains, vents and lids.

659.17. When the verification of compliance is based on full-scale testing, the evaluation of the loss of shielding may be made by putting a suitable radioactive source into the specimen and monitoring the entire outside surface with an appropriate detector, for instance films, Geiger–Müller probes or scintillation probes. For thick shields, a scintillation probe, for example thallium activated NaI of small diameter (about 50 mm), is usually employed because it allows the use of low activity sources, typically Co-60, and because its high sensitivity and small effective diameter permits an easy and effective detection of increased localized dose rates. If measurements are made near the surface of the packaging, care should be taken to measure the dose rate properly (see para. 220A.5 and para. 220A.6). Calculations will then be needed to adjust the measured dose rate to 1 m from the external surface of the package. Finally, unless the radioactive contents for which the package is designed are used in the test, further calculations will be required to adjust the measured values to those that would have existed had the design contents been used.

659.18. The use of lead as a shielding material needs special care. It has a low melting temperature and a high coefficient of expansion and therefore it should be protected from the effects of the thermal test. If it is contained in relatively thin steel cladding that could be breached in the impact test and if the lead melts in the fire, it could escape from the package. Also, owing to its high coefficient of expansion, the lead could burst the cladding in the thermal test and escape. In both these cases, the dose rate could be excessive after the thermal test. To overcome the expansion problem, voids might be left to allow the lead to expand into them, but it should be recognized that, when the lead cools, a void will exist whose position may be difficult to predict. A further problem is that uniform melting of the lead may not necessarily occur, owing to non-uniformities in the packaging structure and in the fire environment. In this event, localized expansion could result in the cladding being breached and a subsequent loss of lead, thus reducing the shielding capability of the package.

659.19. See para. 624.8.

659.20. Additional guidance on testing the integrity of radiation shielding may be found in Refs [43–47].

659.21. Packages designed for the transport of irradiated fuel pose a particular problem in that the activity is concentrated in fission products in fuel pins that have been sealed prior to irradiation. Pins that were intact on loading into the package would generally be expected to retain this activity under normal conditions of transport.

659.22. Under accident conditions of transport, irradiated fuel pins might fail with a subsequent radioactive release into the package containment system. Consequently, data on the fuel fission product inventory, the possible failure rate of pin cladding and the mechanism of activity transfer from the failed pin into the containment system are needed to enable release of activity from the package to be assessed.

659.23. The methods for assessing the leaktightness of packages are generally applied in two ways:

- (a) When the package is designed for a specific function, the radioactive contents are clearly defined and the standard of leaktightness can be established at the design stage.

(b) When an existing package with a known standard of leaktightness is to be used for a purpose other than that for which it was designed, the maximum allowable radioactive material contents have to be determined.

659.24. In the case of a mixture of radionuclides leaking from a Type B(U) package, an effective A_2 may be calculated by the method in para. 405, using the fractional activities of the constituent radionuclides, $f(i)$, which are appropriate to the mixture that can actually leak through the seals. This is not necessarily the fraction within the package itself, since part of the contents may be in solid discrete pieces too large to pass through seal gaps. In general, for leakage of liquids and gases, the fractional quantities relate to the gaseous or dissolved radionuclides. Care is necessary, however, to take account of finely divided, suspended solid material.

659.25. If the package has elastomeric seals, permeation of gases or vapours may cause relatively high leakage rates. Permeation is the passage of a liquid or gas through a solid barrier (which has no direct leakage paths) by an absorption–diffusion process. Where the radioactive material is gaseous (e.g. fission gas), the rate of permeation leakage is determined by the partial pressure of the gas and not by the pressure in the containment system. The tendency of elastomeric materials to absorb gases should also be taken into account.

659.26. It should be noted that, in the case of some large packages, very minor leakage of radioactive material over a long period could result in contamination of the exterior surface. In these cases, it may be necessary to reduce the leakage under normal conditions of transport (para. 659(a)) to ensure that the surface contamination limit (paras 508 and 509) is not exceeded.

660.1. Various risk assessments have been carried out over the years for the sea transport of radioactive material, including those documented in the literature [48, 49]. These studies considered the possibility of a ship carrying packages of radioactive material sinking at various locations; the accident scenarios included a collision followed by sinking, or a collision followed by a fire and then followed by sinking.

660.2. In general, it was found that most situations would lead to negligible harm to the environment and minimal radiation exposure to persons if the packages were not recovered following the accident. It was concluded, however, that if a large irradiated fuel package (or packages) were to be lost on the continental shelf, some long term exposure to persons through the ocean food chain could occur. The radiological impact due to loss of irradiated fuel packages at greater depths or of other radioactive material packages at any depth was found to be orders of magnitude lower than these values. Later studies, which are gathered in Ref. [50], have considered the radiological impact from the loss of other radioactive material that is increasingly being transported by sea in large quantities, such as plutonium and high level radioactive waste. On the basis of these studies, the scope of the enhanced water immersion test requirement was extended in the 1996 Edition of the Transport Regulations to cover any radioactive material transported in a large quantity, not only irradiated nuclear fuel.

660.3. The requirement for a 200 m water submersion test for irradiated fuel packages containing more than 37 PBq of activity was originally added to the 1985 Edition of the Transport Regulations. From the 1996 Edition, the threshold defining ‘large quantity’ has been amended to a multiple of A_2 , which is considered a more appropriate criterion to cover all radioactive material, being based on a consideration of external and internal radiation exposure to persons as a result of an accident. The 200 m depth corresponds approximately to that of the continental shelf and to the depths where the studies mentioned in para. 660.2 indicated that radiological impacts could be significant. Recovery of a package from this depth would be possible and often desirable. Although the impact of the expected radioactive release into the environment would be acceptable, as shown by the risk assessments, the requirement in para. 660 was imposed because salvage would be facilitated after the accident if the containment system

were not ruptured, and therefore there were no release of solid contents from the package. The specific release rate limits for other test conditions (see para. 659) are therefore not applied here.

660.4. In many cases of Type B(U) package design, the need to meet other sections of the Transport Regulations will result in a containment system that is completely unimpaired by immersion in 200 m of water.

660.5. In cases where the containment efficiency is impaired, it is recognized that leakage into the package and subsequent leakage from the package is possible.

660.6. The aim, under conditions of an impaired containment, should be to ensure that only dissolved radioactive material is released. Retention of solid radioactive material in the package reduces the problems in salvaging the package.

660.7. Degradation of the containment system could occur with prolonged immersion and requirement in para. 660 in the Transport Regulations should be conservatively considered as being applicable to immersion periods of about one year, during which recovery of the package should be readily completed.

661.1. An increase in the complexity of the design of a package and any additional uncertainty and possible unreliability associated with filters and mechanical cooling systems implemented to ensure compliance with paras 653 and 659 are not consistent with the philosophy underlying the Type B(U) designation (unilateral competent authority approval). A simpler design approach in which neither filters nor cooling systems are used has a much wider acceptability. This does not preclude the use of cooling systems on vessels.

663.1. After the closure of a package, the internal pressure may rise. There are several mechanisms that could contribute to such a rise, including: exposure of the package to a high ambient temperature; exposure to solar heating (i.e. insolation); heat from the radioactive decay of the contents, chemical reaction of the contents, or (in the case of water filled designs) radiolysis; or combinations thereof. The maximum value that the summation of all such potential pressure contributors can be expected to produce under normal operating conditions is referred to as the MNOP (see paras 229.1–229.3).

663.2. Such a pressure could adversely affect the performance of the package and consequently needs to be taken into account in the assessment of performance under normal operating conditions.

663.3. Similarly, in the assessment of the ability to withstand accident conditions (paras 726–729), the presence of a pre-existing pressure could present more onerous conditions against which satisfactory package performance is required to be demonstrated; consequently, the MNOP needs to be assumed in defining the pre-test condition (see paras 229.1–229.3). If justifiable, pressures different from the MNOP may be used provided the results are corrected to reflect the MNOP.

663.4. Type B(U) packages are generally not pressure vessels and do not readily fit within the various codes and regulations that cover such vessels. For the tests required to verify the ability of a Type B(U) package to withstand both normal and accident conditions of transport, assessment under the condition of MNOP is required. Under normal transport conditions, the prime design considerations are to provide adequate shielding and to restrict radioactive leakage under quite modest internal pressures. The accident situation represents a single extreme incident, following which reuse is not considered as a design objective. Such an extreme incident is characterized by single, short duration high stress cycles during the mechanical tests at normal operating temperature, followed by a single, long duration stress cycle induced by the temperatures and pressures created during the thermal test. Neither of these stress cycles fit the typical pattern of loading of pressure vessels, the design of which is concerned with time

dependent degradation processes such as creep, fatigue, crack growth and corrosion. For this reason, specific reference to the allowable stress levels has not been included in the Transport Regulations. Instead, strains in the containment system are restricted to values that will not affect its ability to meet the applicable requirements. Whilst other criteria might eventually assume importance, it is for the containment of radioactive material that the containment system exists. Before a fracture occurs, it is likely that containment systems, particularly in reusable packagings with mechanically sealed joints, will leak. The extent to which the strains in the various components distort the containment system and impair its sealing integrity should therefore be determined. Reduction of seal compression brought about, for example, by bolt extensions and local damage due to impact and by rotations of seal faces during thermal transients need to be assessed. One assessment technique is to predict the distortions on impact directly from drop tests on representative scale models and to combine these with the distortions calculated to arise during the thermal test using a recognized and validated computer code. The effects upon sealing integrity of the total distortion may then be determined by experiments on representative sealed joints with appropriately reduced seal compressions.

663.5. The MNOP should be determined in accordance with the definition given in para. 229.

663.6. The strains in a containment system under normal conditions of transport at MNOP should be within the elastic range. The strains under accident conditions of transport should not exceed the strains that would allow leakage rates greater than those stated in para. 659(b), nor increase the external dose rate beyond the requirements of para. 659.

663.7. When analysis is used to evaluate package performance, the MNOP should be used as a boundary condition for the calculation of the effect of the tests for demonstrating ability to withstand normal conditions of transport and as an initial condition for the calculation of the effect of the tests for demonstrating ability to withstand accident conditions of transport.

664.1. The requirement that the MNOP should not exceed a gauge pressure of 700 kPa is the specified limit for Type B(U) packages to be acceptable for unilateral approval.

665.1. Special attention should be given to the interaction between the LDRM and the packaging during normal and accident conditions of transport. This interaction should not damage the encapsulation, cladding or other matrix, nor cause comminution of the material itself to a degree that would change the characteristics as demonstrated by the requirements of para. 605.

666.1. The lower temperature is important because of pressure increases from materials that expand upon freezing (e.g. water), possible brittle fracture of many metals (including some steels) at reduced temperature and possible loss of resilience of seal materials. Of these effects, only fracture of materials could lead to irreversible damage. Some elastomers that provide good high temperature performance (e.g. fluorocarbons such as Viton compounds) lose their resilience at temperatures of -20°C or less. This can lead to narrow gaps of a few micrometres arising from differential thermal expansion between the metal components and the elastomer. This effect is fully reversible. In addition, freezing of any humid contents and internal pressure drop at low temperatures could prevent leakage from the containment. Therefore, in certain cases, the use of such elastomeric seals could be accepted (see Refs [51, 52] for further information). The lower temperature limit of -40°C and the upper temperature limit of 38°C are reasonable bounding values for ambient temperatures that could be experienced during transport of radioactive material in most geographical regions at most times of the year. However, it should be recognized that in certain areas of the world (extreme northern and southern latitudes during their winter periods and dry desert regions during their summer periods) temperature extremes below -40°C and above 38°C are possible. Averaged over area and time, however, the instances of temperatures falling outside the range -40°C to 38°C are expected to be minimal.

666.2. See Appendix V for guidelines for the safe design of shipping packages against brittle fracture.

666.3. In assessing a package design for low temperature performance, the heating effect of the radioactive contents (i.e. which could prevent the temperatures of package components from falling to the minimum limiting ambient design temperature of -40°C) should be ignored. This will allow package response (including structural and sealing material behaviour) at the low temperature to be evaluated for handling, transport and in-transit storage conditions. Conversely, in evaluating a package design for high temperature performance, the effect of the maximum possible heating by the radioactive contents, as well as insolation and the maximum limiting ambient design temperature of 38°C , should be considered simultaneously.

REQUIREMENTS FOR TYPE B(M) PACKAGES

667.1. The intent is that the requirements for Type B(M) packages, as designed and used, provide a level of safety equivalent to that provided by Type B(U) packages.

667.2. Departures from the requirements given in paras 639, 655–657 and 660–666 are acceptable in some situations, with the agreement of the relevant competent authority(ies). Examples of this could be a reduction in the ambient temperature range and insolation values taken for design purposes if the Type B(U) requirements are not considered applicable (paras 639, 655–657 and 666), or making allowance for the heating effect of the radioactive contents.

668.1. For the contents of some packages, as a result of the mechanisms described in para. 663.1, the pressure tends to build up and if not relieved might eventually cause failure of the package, or reduce the useful lifetime of the package through fatigue. To avoid this, para. 668 allows the package design to include a provision for intermittent venting. Such vented packages are required by the Transport Regulations to be shipped as Type B(M) packages.

668.2. To provide a level of safety equivalent to that which would be provided by a Type B(U) package, the design may specify that only gaseous materials be allowed to be vented, that filters or alternative containment be used, or that venting may only be performed under the direction of a qualified health physicist.

668.3. Intermittent venting is permitted in order to allow a package to be relieved of a buildup of pressure that might, under normal conditions of transport (see paras 719–724) or when the package is subjected to the thermal test (see para. 728), cause it to fail to meet the requirements of the Transport Regulations. However, the release of radioactive contents under normal conditions and under accident conditions where no operational controls are used is limited by the requirements of para. 659.

668.4. As there is no specified limit for radioactive release for intermittent venting where operational controls are used, it should be demonstrated to the competent authority, using a model that relates as closely as possible to the actual conditions of package venting, that transport workers and members of the public will not be exposed to doses in excess of the limits set out in national regulations. When the intermittent venting operation is taking place under the control of a person qualified in radiation protection, the release may be varied depending on their advice, with account taken of measurements made during the operation to ensure that workers and members of the public are adequately protected.

668.5. the following factors should be taken into account, as a minimum, when considering the exposures arising from intermittent venting:

(a) Exposure due to normal radioactive leakage and to external radiation from the package;

- (b) Location and orientation of the venting orifice in relation to the working position of operating personnel and the proximity of other workers and members of the public;
- (c) Occupancy factors of workers and members of the public;
- (d) Physical and chemical nature of the material being vented, for example, gaseous (halogen, inert gas), particulate, soluble or insoluble;
- (e) Other doses received by workers and the public.

668.6. In assessing the adequacy of the intermittent venting operation, account should be taken of possible detriment arising from retaining and disposing of the released radioactive material rather than allowing it to disperse.

REQUIREMENTS FOR TYPE C PACKAGES

669.1. Analogous to a Type B(U) or Type B(M) package, the concept of a Type C package is that it is capable of withstanding severe accident conditions in air transport without loss of containment or an increase in external dose rate to an extent that would endanger the public or those involved in rescue or cleanup operations. The package could be safely recovered, but it would not necessarily be capable of being reused.

669.2. The contents limits for Type C packages, as specified on the approval certificates, take into account the testing requirements for a Type C package, which reflect the potentially very severe accident conditions that could be encountered in a severe air transport accident. It is also required that the physical and chemical nature of the contents are compatible with the containment system (para. 614 of the Transport Regulations).

670.1. One of the potential post-crash scenarios is package burial. Packages involved in a high velocity crash may be covered by debris or buried in soil. If packages whose contents generate heat become buried, an increase in package temperature and internal pressure may result.

670.2. Compliance with the requirements specified in para. 670 of the Transport Regulations for burial conditions should be demonstrated using conservative calculations or validated computer codes. The evaluation of the condition of a buried package should take into account the integrity of both the shielding and the containment system, in accordance with the requirements specified in para. 659(b). Since it is required in para. 670 that the assessment assumes that the thermal insulation remains intact, special attention should be given to the heat dissipation capability and the change in internal pressure under burial conditions.

671.1. The Type C package provides similar levels of protection for a severe accident during transport by air, as for Type B(U) or Type B(M) packages involved in a severe accident during other modes of transport. To achieve this, the same requirements on increased external dose rate and loss of contents are established in the tests for Type B and Type C packages for accident conditions.

671.2. See paras 659.1–659.26 for further explanatory material on requirements for dose rate and material release limits that also apply to Type C packages.

672.1. As a Type C package may be immersed in a lake, inland sea, or on the continental shelf where recovery is possible, the enhanced immersion test is required for all Type C packages regardless of the total activity in the package.

672.2. In an air accident over a body of water, a package could be submerged for a period of time pending recovery. Large hydrostatic pressures could be applied to the package, depending upon the depth of submersion. Of primary concern is the possible rupture of the containment system. An additional consideration is recovery of the package before severe corrosion develops.

672.3. The 200 m depth requirement corresponds approximately to the maximum depth of the continental shelf. Recovery of a package from this depth would be possible and desirable. The acceptance criteria for the immersion test is that there is no rupture of the containment system. Further advice may be found in paras 660.2, 660.3 and 660.5–660.7.

672.4. As the sea represents a softer impact surface than land, it is sufficient that the immersion test be an individual demonstration requirement; that is, non-sequential to other tests.

REQUIREMENTS FOR PACKAGES CONTAINING FISSILE MATERIAL

673.1. The requirements for packages containing fissile material are additional requirements imposed to ensure that packages with fissile material contents will remain subcritical under normal and accident conditions of transport. All other relevant requirements of the Transport Regulations are also to be met. The system for implementing criticality control in transport is prescribed in Section V of the Transport Regulations. This control is also based on design requirements and specifications in Section VI, on approval certificates issued in accordance with Section VIII, as well as on classification in accordance with Section IV.

673.2. Packages containing fissile material are required to be designed and transported in such a way that an accidental criticality is avoided. Criticality would occur if the fission chain reactions become self-supporting due to the balance between the neutron production and the neutron loss by absorption in, and leakage from, the system. Package design involves consideration of many parameters that influence neutron interaction (see Appendix VI). It is necessary that the criticality safety assessment consider these various parameters and ensure that the system will remain subcritical in both normal and accident conditions of transport. Assessments should be performed by qualified persons experienced in the physics of criticality safety (see Appendix VI).

673.3. The contingencies discussed in para. 673(a) are typical ones that may be important and should be carefully considered in the criticality safety assessments. Depending on the package design and any special conditions anticipated in transport or handling, other contingencies may need to be considered to ensure that subcriticality is maintained under all credible transport conditions. For example, if the test results show movement of the fissile or neutron absorber material in the package, then the uncertainty limits that bound this movement should be considered in the criticality safety assessments. It should be taken into account that the prototype used in testing might vary from the production models in detail, in manufacturing method and in manufacturing quality. The as-built dimensions of the prototype may need to be known to examine the effect of tolerances on the tests. The difference between tested models and production models needs to be considered. The goal is to obtain the maximum credible neutron multiplication and confirm subcriticality is ensured for these conditions.

673.4. Water influences criticality safety in several ways. When it is added to or removed from fissile material, the resulting neutron moderation can significantly reduce the amount of fissile material required to achieve criticality. As a reflector of neutrons, water may increase or reduce the neutron multiplication factor. Thick layers of full density water (~30 cm) between packages reduce neutron interaction in an array to an insignificant level [53, 54]. The criticality assessment should consider the changes in package geometry or conditions that might cause water to behave mainly as a moderator, a reflector or an absorber. All forms of water should be considered, including snow, ice, steam, vapour and sprays. These low density forms of water may produce (particularly in considering interstitial water

between packages) a neutron multiplication higher than that seen with full density water (see Appendix VI). The need for low density forms of water to be considered does not mean that they have to be taken into account if the scenario is not credible. For example, selective flooding of a fuel element package could be credible or not, depending on the specific design.

673.5. In addition to water leaking into or out of packages, the presence of residual water in the packages before transport in the internal cavity — for example, after draining and/or drying operations, in broken pins and in water traps — needs to be considered. Moreover, the possibility of human error during drying operations should be prevented by independent verification and the drying efficiency should be guaranteed.

673.6. Neutron absorbers are sometimes employed in the packaging and/or in the contents to reduce the effect of moderation and the contribution to the neutron multiplication resulting from interaction among packages (see para. 501.8). Typical neutron absorber materials used for criticality control are most effective when a neutron moderator is also present to reduce the neutron energy. The loss of effectiveness of neutron absorbers, for example, by corrosion and/or redistribution, or, as in the case of contained powders, by settling, can have a marked effect on the neutron multiplication factor.

673.7. Paragraph 673(a)(iii) and (iv) addresses contingencies arising from dimensional changes or movement of the contents during transport. Feasible rearrangements of the packaging or contents, including those due to the normal or accident tests, are required to be considered in establishing the margin of subcriticality. Indications of dimensional changes during the tests should cause the evaluator to assess the effect of these changes on the neutron multiplication. A loss of the fissile material from the array of packages considered in para. 685 needs to be limited to a subcritical quantity. This subcritical quantity should be consistent with the type of contents, with optimum water moderation and with reflection by 20 cm of full density water, unless a more efficient moderator is already present in the package. The reduction of spaces between packages, because of possible damage to the package incurred during transport, will have a direct effect on the neutron interaction among packages; thus, it requires consideration. The effect on reactivity of tolerances on dimensions and material compositions should be considered. It is not always obvious whether particular dimensions or compositions should be maximized or minimized or how, in combination, they affect the neutron multiplication factor. Many calculations may need to be performed in order that the maximum neutron multiplication factor of the system can be determined or an appropriate allowance for these contingencies can be developed.

673.8. The effects of temperature changes (para. 673(a)(vi)) on the stability of fissile material and/or on the neutron interaction properties are required to be examined. For example, uranium systems dominated by very low energy (thermal) neutrons have an increase in neutron multiplication as the temperature is reduced. Temperature changes may also influence the package integrity. The temperatures that should be considered include those resulting from the ambient conditions specified in para. 679 and those of the tests (para. 728 or 736, as appropriate).

674.1. Paragraph 674 provides criteria by which fissile material may be transported using a package design that does not have to be certified by a competent authority to contain fissile material. Rather, if the mass of fissile nuclides is limited to the specified quantities and the package meets the criteria in para. 674(a), (b) or (c), then the package will be safe for transport subject to CSI accumulation control. These provisions were incorporated in the 2012 Edition of the Transport Regulations, and their technical background and detail guidance for application are provided in Ref. [55]. The safety assessment performed by Member States [56] assumed that the fissile material that complies with the specified mass limits in para. 674(d) when loaded in packages meeting the requirement of para. 674 (a), (b) or (c) also complies with the requirements of paras 676–686, even in the case of complete loss of packaging under accident conditions. The safety assessments demonstrated that subcriticality would be ensured

with the same margin of safety expected of packages certified by competent authorities as containing fissile material. The actual packaging (e.g. Type IP, Type A, Type B(U), Type B(M)) to be used is not specified. However, there are packaging requirements that need to be confirmed prior to shipment.

674.2. CSI values derived in accordance with para. 674 are used in the same way as CSIs derived for competent authority approved fissile package designs. A shipment may consist of any combination of CSI controlled packages, regardless of how the CSIs were derived, subject only to the limits on the sum of CSIs in para. 566(c). Each package will be classified using the “FISSILE” UN number and Proper Shipping Name from Table 1 of the Transport Regulations appropriate to its radioactive properties (LSA, SCO, Type A, Type B(U), Type B(M)). It was not considered necessary to introduce additional FISSILE classifications for packages complying with para. 674 because the radioactive hazard is indicated by the UN number, and the word “FISSILE”, together with the CSI label, indicates the need for accumulation control.

674.3. The CSI equations in para. 674 are identical to those in para. 686 but expressed in a way that clearly shows the relationship between the package CSI and the package fissile material mass as a fraction of the safe subcritical mass limits (Z) of Table 13. The fissile material may be transported in any package appropriate to its radioactive properties without the need to obtain competent authority approval regarding the fissile aspects. However, an approval may be required by their radioactive properties. Accumulation control is achieved using the CSI calculated for each package by using the formulae in para. 674, which are based on the fissile nuclide(s) present, their mass and the package size and integrity, as required by para. 674(a)–(c). The total CSI that may be transported is the same as that for packages complying with competent authority approved package designs.

674.4. The mass limits and specifications for low neutron absorbing moderators such as beryllium, deuterium and graphite or carbon are set to ensure that their effects on neutron multiplication are negligible [55, 56]. These package limits have to be adhered to during the loading of the package. The original intent of “material” in the text of “1 g in any 1000 g of material” in para. 674 was mineral material contained in filling material such as concrete, rock or sand in waste packages; however, from analysis models in Ref. [57, 58] it covers every material in a consignment, including packagings and radioactive contents. Beryllium incorporated in copper alloys up to 4% in weight of alloy also has a negligible effect on neutron multiplication [59].

674.5. The values in Table 13 are subcritical mass values and were selected to be approximately 85% of calculated critical mass values assuming optimum moderation of the fissile material and 20 cm of water reflection. The values in Table 13 were accepted as the consensus mass values by Member States’ criticality experts [55, 56].

674.6. Paragraph 674(a) does not require the use of a package that will retain its contents under normal conditions of transport and consequently the “2N” accident condition array is bounded by the “5N” normal condition of transport array. Safety is therefore ensured by limiting the total mass of fissile nuclides in any group of packages having a total CSI of 50 to 1/5 of a subcritical mass in order to provide the same standards of safety as for packages complying with competent authority approved package designs.

674.7. Paragraph 674(b) requires that a package retain its contents under normal conditions of transport. It limits the total mass of fissile nuclides in a group of packages having a total CSI of 50 to 1/2 of a subcritical mass, which was agreed to provide an adequate margin of subcriticality. The use of 1/2 a subcritical mass will ensure safety under accident conditions in that two such package groups will be subcritical and is analogous to the requirement in para. 685 that “2N” packages be subcritical following an accident. To ensure the safety of five groups of packages under normal conditions of transport, as required by para. 684, it is necessary to limit the mass of fissile nuclides in any one package and to

specify a minimum package size that is kept after tests for normal conditions of transport. In deriving the values in Table 13, calculations [56] showed that if the package mass is limited by imposing a maximum CSI of 10 for any package then a minimum package dimension of 30 cm is required to ensure subcriticality.

674.8. Paragraph 674(c) covers situations where the 30 cm minimum package dimension under normal conditions of transport, as stated in para. 674(b), does not apply or cannot be guaranteed. The 15 g single package limit is deliberately chosen to be the same limit as in para. 417(a) of the 2009 Edition of the Transport Regulations to facilitate transition from previous provisions, where the 15 g fissile exception was supplemented by a consignment limit. Paragraph 674(c) does not allow credit for lower enrichments and the Table 13 parameters for 100% enriched uranium are required to be used, regardless of the actual enrichment. If there is a need to take credit for lower enrichments, a package design approval under paras 684 and 685 should be easily obtained on the same principles as the provisions in para. 674.

674.9. The lack of a requirement for multilateral approval in para. 674 means that the specifications and requirements are subject to self-assessment by the consignor. For para. 674(b) and (c), this includes verification that, after normal condition tests, each package retains its fissile contents and that it retains the required minimum external dimension. This self-assessment requires vigilance in the selection and loading of the package consistent with an adequate management system.

In comparison with former provisions for transporting fissile material without competent authority approval of the package design, the requirements of para. 674 replace the consignment limit to be complied with by the consignor by a CSI controlled conveyance limit (precisely, a limit on a group of packages) enforced by CSI labels on the packages. This addresses concerns about loading several consignments of packages on one conveyance and exceeding a minimum critical mass on the conveyance.

Additionally, para. 674 limits the total mass of fissile nuclides in one package compared with the provisions in para. 417(a)(ii) and (iii) of the 2009 Edition of the Transport Regulations where the mass of fissile nuclides per package was limited only by the conveyance limit. It was found that applying a limit for the CSI of any package provided more control than was required under para. 417(a)(i) of the 2009 Edition of the Transport Regulations.

Further, classification as FISSILE does not allow the use of excepted packages, thus enhancing control during transport.

The new requirements have a sound technical base (opening possibilities for future development) in which all features necessary for safety are unambiguously required in the Transport Regulations. The properties of each package (containment and minimum external dimensions under normal conditions) were previously assumed and not required. Accumulation control of packages in a consignment was required but the method was left for subjective implementation that may have been different for each consignment. Accumulation control of multiple consignments was not required at all but was assumed to exist. It is important to recognize that, when establishing the requirements, it has been taken into account that failure of the packages, applying para. 674, cannot credibly lead to criticality. The technical basis for this can be found in Ref. [58].

The requirements on control of accumulation for CSI permit higher amounts of fissile material when transported under exclusive use (Table 11 of the Transport Regulations), subject to multilateral shipment approval (as the sum of the CSIs of the packages in a single freight container or in a single conveyance would exceed 50) (para. 825 (c) in the Transport Regulations). In this case, there is the option for the competent authorities to scrutinize the specifications used in the application of para. 674.

674.10. The provisions of para. 674 are used to permit the transport of fissile material without the need to obtain competent authority approval for a specific package design. Any form of fissile material may be transported under para. 674, the only necessity is to know the mass of fissile nuclides in the package. Two examples where para. 674 might be used are described below:

(i) *Packages formerly shipped under para. 417(a)(i) of the 2009 Edition of the Transport Regulations*

This example covers the transport of small quantities of ‘pure’ fissile material such as unpoisoned enriched uranium fuel pellets. Such material cannot be excepted from classification as fissile under para. 417(a) or (b). Neither would it ever be possible to obtain an exception under para. 417(f) as there is not a sufficient quantity of non-fissile material to maintain subcriticality without accumulation control (see para. 606). Very small quantities might be excepted from classification as fissile material under para. 417(c) or (d). However, if these conditions are not met, this material is required to be classified as fissile and shipped with limits on the mass of material per package and/or the number of packages that may be transported.

Previously, such material could have been shipped as fissile excepted using the 15 g package limit plus a consignment limit from para. 417(a)(i) of the 2009 Edition of the Transport Regulations. This exception included in para. 417(a)(i) of the 2009 Edition of the Transport Regulations has been withdrawn for serious safety reasons and para. 674 will provide a method of transporting this material without the need to obtain competent authority approval.

The mass of fissile nuclides in each package should be used to calculate its CSI. The package will be labelled with an appropriate FISSILE UN number plus a CSI label and transported, subject to the limits on total CSI given in Table 11.

The specific subparagraph of para. 674 to be used will depend on the type of the package, as follows:

- (a) If the package is Type IP-2 or above and the consignor can demonstrate a minimum external dimension of 30 cm under normal conditions of transport then the CSI may be calculated using the provisions of para. 674(b). For 5% enriched uranium, the maximum permitted CSI of 10 implies an individual package limit of 85 g U-235. The CSI limits in Table 11 mean that a total of 425 g U-235 could be transported on a conveyance (i.e. in a group of packages having a total CSI of 50), or else 850 g of U-235 could be transported under exclusive use having a total CSI on the conveyance of 100. This compares with the previous 15 g package limit and 290 g consignment limit (or 400 g if water moderation only can be assumed).
- (b) If the consignor cannot demonstrate containment under normal conditions of transport, the provisions of para. 674(a) should be used, which will result in higher CSIs than para. 674(b). This would be the case if a Type IP-2 package had been approved under the alternative tests of para. 626 and the consignor cannot (or chooses not to) demonstrate containment under normal conditions of transport. For 5% enriched uranium, the maximum CSI of 10 gives a package mass limit of 34 g of U-235 and a conveyance limit of 170 g of U-235, or else 340 g under exclusive use having a total CSI of 100 on the conveyance.
- (c) If the package can be demonstrated as retaining its contents under normal conditions of transport but not maintaining a minimum dimension of 30 cm, then para. 674(c) would be used with the explicit package mass limit of 15 g of U-235, subject to a minimal external package dimension of 10 cm. In the case of 5% enriched uranium, the conveyance limit is 225 g of U-235, or else 450 g under exclusive use having a total CSI of 100 on the conveyance.

These package mass limits are equal to or greater than the previous 15 g exception limit regardless of which subparagraph of para. 674 is used. This is important for packages that have already been loaded in accordance with the previous 15 g exception as they can be shipped without repacking. The mass of fissile material that may be transported on a conveyance is reduced in some cases. However, there is a consensus that permitting $\frac{1}{2}$ a critical mass per consignment with no control over the number of consignments on a conveyance, which was the case with the old 15 g exception, is not safe. It should be noted that if exclusive use were used, then twice the mass of fissile nuclides can be transported on a conveyance (Table 11 of the Transport Regulations), subject to multilateral shipment approval (as the sum of the CSIs of the packages in a single freight container or in a single conveyance would exceed 50, see para. 825(c) in the Transport Regulations).

LSA-I material used to be transported in IP-1 packages under the previous fissile exceptions. However, it should be noted that the provisions of para. 674 cannot be used for these materials as the shipments are classified as FISSILE and the transport of fissile LSA-I is not permitted.

If the uranium enrichment were to be 1.5% or less then the package and conveyance limits will be significantly higher than in this example.

For uranium enrichments above 5%, the package and conveyance limits will be lower. For 100% enriched uranium, the package mass limits are 18 g, 45 g and 15 g for para. 674(a), (b) and (c) respectively. The conveyance limits will be 90 g, 225 g and 225 g for a total CSI of 50, and, under exclusive use, 180 g, 450 g and 450 g, respectively, for a total CSI of 100. It should be noted that the conveyance limits using para. 674(b) and (c) are identical in this example.

(ii) Packages formerly shipped under para. 417(a)(iii) of the 2009 Edition of the Transport Regulations

This example covers non-fissile material contaminated by fissile nuclides (e.g. waste products) that previously would have been transported as fissile excepted using the '5 g in 10 L' exception in para. 417(a)(iii) of the 2009 Edition of Transport Regulations. There is a consensus that this exception did not provide sufficient safety and consequently it has been withdrawn. Packages meeting the old '5 g in 10 L' exception are likely (but not certain) to contain a significantly higher mass of non-fissile material compared to the mass of fissile nuclides. It is therefore likely that in many cases, exception from fissile classification under para. 417(f) could be obtained. However, there will be material for which this is not possible or practicable because:

- (a) The consignor does not wish to demonstrate to the competent authority compliance with the requirements of para. 606.
- (b) The material cannot be sufficiently characterized to demonstrate compliance with the requirement of para. 606, or else the effort needed to do so is excessive. This will be especially relevant for packages that have already been loaded in accordance with the previous '5 g in 10 L' exception and where the contents may not be certain, apart from the fissile mass.
- (c) An individual package contains small enough quantities of fissile material to be excepted from FISSILE classification under para. 417(c) or (d). However, these limits are very low and this is unlikely. In these cases, para. 674 provides a mechanism for transporting the material without the need to obtain competent authority approval.

The resulting mass limits will be the same as in the above example (i). Packages loaded to the previous '5 g in 10 L' exception could contain significant quantities of fissile nuclides. Package mass limits resulting from the use of para. 674 could be limiting, especially for higher enrichments.

674.11. It is important to recognize that the identification mark “F” does not relate directly to criticality safety or emergency preparedness. It is only an indicator that a multilateral approval certificate for the package design is available for each country on whose territory the consignment is shipped. The UN number classification “FISSILE” carries information related to criticality safety and emergency preparedness. A consignment of packages with fissile material under routine conditions of transport may be close to (about 85%) a critical mass without any package having an identification mark “F” (see para. 674). The 2009 and earlier editions of the Transport Regulations did not have any UN classification number, CSI label or identification mark to indicate the need for criticality safety control for such consignments. Later editions required UN classification as “FISSILE” and CSI labels for packages in such consignments.

675.1. Subcriticality in the transport of the quantity of plutonium specified in para. 675 is ensured by the requirement for CSI control. The CSI formula will limit the conveyance to 1 kg of specified material that, owing to the nature of plutonium, will be contained in Type B(U) or Type B(M) packages. Monte Carlo analysis indicates that 6.8 kg of material with 80% Pu-238 and 20% Pu-239 by weight is needed to provide a critical mass in terms of a fully water reflected metal sphere (see Ref. [60]).

Contents specification for assessments of packages containing fissile material

676.1. Values of unknown or uncertain parameters are required to be appropriately selected to produce the maximum neutron multiplication factor for the assessments as described in paras 673–685. In practice, this requirement may be met by taking the effect of these uncertainties into account by a suitable allowance in the acceptance criteria. Mixtures whose contents are not well defined are often generated as by-products of production operations, for example, contaminated work clothes, gloves or tools, residues of chemical analyses and operations, floor sweepings, and as direct products from waste processing operations. It is important to determine the combination of parameters that produce the maximum neutron multiplication. Thus, the criticality safety assessment should identify the unknown parameters and explain the interrelationship of the parameters and their effects on neutron multiplication. The range of values possible (based on available information and consistent with the nature of the material involved) should be determined for each parameter, and the neutron multiplication factor for any possible combination of parameter values should be shown to satisfy the acceptance criteria. This principle should also be applied to the irradiation characteristics used to determine the isotopic composition of irradiated nuclear fuel.

676.2. Where the number of possible parameters is very large, the probability of them all achieving their most reactive value during normal or accident conditions of transport might be extremely small. In such cases it may not be necessary for a criticality safety assessment to assess all possible permutations provided the competent authority is satisfied that criticality safety has been adequately demonstrated.

677.1. The requirements for the criticality assessment of irradiated nuclear fuel are addressed in para. 677. The major objective is to ensure that the radionuclide contents used in the safety assessment provide a conservative estimate of the neutron multiplication in comparison with the actual loading in the package. Irradiation of fissile material typically depletes the fissile nuclide content and produces actinides, which contribute to neutron production and absorption, and fission products, which contribute to neutron absorption. The long term, combined effect of this change in the isotopic composition is to reduce the reactivity from that of the unirradiated state. However, reactor fuel designs that incorporate fixed neutron burnable poisons can experience an increase in reactivity for short term irradiations where the reactivity gain due to depletion of the fixed neutron poisons is greater than the reactivity loss due to the change in the fuel composition. If the assessment uses an isotopic composition that does not correspond to a condition greater than or equal to the maximum neutron multiplication during the irradiation history, then the assumed composition of the fissile material should be demonstrated as

providing a conservative neutron multiplication for the known characteristics of the irradiated nuclear fuel, as loaded in the package.

677.2. Unless it can be demonstrated in the criticality assessment that the maximum neutron multiplication during the credible irradiation history is provided, a pre-shipment measurement needs to be performed to ensure that the fissile material characteristics meet the criteria (e.g. total exposure and decay) specified in the assessment (see para. 503.8). The requirement for a pre-shipment measurement is consistent with the requirement to ensure the presence of fixed neutron poisons (see para. 501.8) or removable neutron poisons (see para. 503.4), where required by the package design approval certificate, that are used for criticality control. In the case of irradiated nuclear fuel, the depletion of the fissile radionuclides and the buildup of neutron absorbing actinides and fission products may provide an inherent measure of criticality control. If such is relied on to ascertain subcriticality, sufficient burnup should be ensured.

677.3. The maximum neutron multiplication often occurs in the unirradiated state. However, one method of extending the useful residence time of fissile material in a reactor is to add a distributed, fixed neutron burnable poison, allowing a larger initial fissile nuclide content than would otherwise be present. These reactor fuel designs with burnable poisons can experience an increase in reactivity for short term irradiations where the reactivity gain due to depletion of the fixed neutron poisons is greater than the reactivity loss due to change in the fuel composition. No pre-shipment measurement is required when such fuel is treated in the criticality assessment as both unirradiated and unpoisoned since this will provide a conservative estimate of the maximum neutron multiplication during the irradiation history. The requirements of para. 677(a) therefore apply, not those of para. 677(b). In addition, breeder reactor fuel and production reactor fuel may have multiplication factors that could increase with irradiation time.

677.4. The evaluation of the neutron multiplication factor for irradiated nuclear fuel is required to consider the same performance standards as for unirradiated nuclear fuel (see paras 680–685). However, the assessment for irradiated nuclear fuel is required to determine the isotopic composition and distribution consistent with the information available on the irradiation history. The isotopic composition of a particular fuel assembly in a reactor depends, to varying degrees, on the initial radionuclide abundance, the specific power, the reactor operating history (including moderator temperature, soluble boron and reactor assembly location), the presence of burnable poisons or control rods, and the cooling time after discharge. Seldom, if ever, are all the irradiation parameters known to the safety analyst. Therefore, the requirements of para. 676 regarding unknown parameters have to be considered. The information typically available for irradiated nuclear fuel characterization is the initial fuel composition, the average assembly burnup and the cooling time. Data on the operating history, axial burnup distribution and presence of burnable poisons should typically be based on general knowledge of reactor performance for the irradiated nuclear fuel under consideration. Paragraph 676 requires that the radionuclide composition and distribution determined using the known and assumed irradiation parameters and decay time will provide a conservative estimate of the neutron multiplication factor after taking into account biases and uncertainties. Conservatism could be demonstrated by ignoring all or portions of the fission products and/or actinide absorbers or assuming lower burnup than is actually the case. The axial radionuclide distribution of an irradiated fuel assembly is very important because the region of reduced burnup at the ends of an assembly may cause increased reactivity in comparison with an assembly where the average burnup is assumed for the isotopic composition over the entire axial height. More information applicable to this subject can be found in Refs [61–64].

677.5. Computational methods used to determine the neutron multiplication should be validated, preferably against applicable measured data (see Appendix VI). For irradiated nuclear fuel, this validation should include comparison with measured radionuclide data. The results of this validation

should be included in determining the uncertainties and biases normally associated with the calculated neutron multiplication. Fission product cross-sections can be important in criticality safety analysis for irradiated nuclear fuel. Fission product cross-section measurements and evaluations over broad energy ranges have not been emphasized to the extent that actinide cross-sections have. Therefore, the adequacy of fission product cross-sections used in the assessment should be considered and justified by the safety analyst.

Geometry and temperature requirements

678.1. This requirement applies to the criticality assessment of packages in normal conditions of transport. The prevention of entry of a 10 cm cube is of concern when open, 'birdcage' types of package are used. This requirement can also be viewed as providing a criterion for evaluating the integrity of the outer container of the package. Packages exist that have similar features to the birdcage design but whose protrusions beyond the closed envelope (the 'bird') of the packaging exist not to provide spacing between units in an array, but, for example, to limit the effects of impacts. Where no credit is taken for these features in the spacing of units, a 10 cm cube behind or between the protrusions (but outside the closed envelope of the packaging) should not be considered to have 'entered' the package.

679.1. Departure from the temperature range of -40°C to 38°C may be acceptable in some situations, with the agreement of the competent authority. Where the assessment of the fissile aspects of the package in relation to its response to the regulatory tests would be adversely affected by ambient temperatures, the competent authority should specify in the certificate of approval the ambient temperature range for which the package is approved.

Assessment of an individual package in isolation

680.1. Owing to the significant effect water can have on the neutron multiplication of fissile material, the criticality assessment of a package requires consideration of water being present in all void spaces within a package to the extent of causing maximum neutron multiplication. The presence of water may be excepted from those void spaces protected by special features that remain watertight under accident conditions of transport. Credible conditions of transport that might provide preferential flooding of packages leading to an increase in neutron multiplication should be considered.

680.2. To be considered 'watertight' for the purposes of preventing in-leakage or out-leakage of water related to criticality safety, the effects of both the normal and accident condition tests need to be considered. Leakage criteria for watertightness should be established in the application for multilateral approval for each package design and accepted by the competent authority. These criteria should be demonstrated as being achievable in both the tests and in the production models.

680.3. The neutron multiplication for packages containing uranium hexafluoride is very sensitive to the amount of hydrogen in the package. Owing to this sensitivity, careful attention has been given to restrict the possibility of water leaking into the package. The persons responsible for testing, preparation, maintenance and transport of these packages should be aware of the sensitivity of the neutron multiplication in uranium hexafluoride to even small amounts of water and should ensure that the special features defined here are strictly adhered to.

680.4. For packages containing uranium hexafluoride, with a maximum uranium enrichment of 5 mass per cent U-235, the requirements of para. 680(b)(ii) may be fulfilled using a uranium hexafluoride package filling system throughout the filling process or by employing other tests acceptable to the competent authority.

680.5. The packaging components that are relied upon to preserve criticality safety should be explicitly defined. The packaging components that are relied upon to maintain containment and geometry control of the fissile material should comprise engineered features whose design is defined in the drawings of the packaging. These components should be included in any physical tests or engineering evaluations performed for the package for normal conditions of transport and hypothetical accident conditions, as applicable (see para. 681.1). Handling items, such as bags, boxes and cans that are used solely as product containers or to facilitate handling of the radioactive material should be assessed for any potential negative impact on package performance, including structural, thermal and criticality safety.

680.6. Any quantity of homogeneous uranium hexafluoride with a maximum uranium enrichment of 5 mass per cent U-235 and less than 0.5% impurities (taking hydrogenous materials into account) is subcritical. Impurities in commercial enriched uranium hexafluoride are limited to 0.5%, in accordance with the ASTM-C996-90 standard [64] (see also para. 420.1).

680.7. The requirement to prevent not only leakage, but also physical contact of the valve and plug is based on criticality safety considerations and, in conjunction with a high degree of quality control, is considered as one kind of special feature.

681.1. The part of the package and contents that makes up the confinement system (see paras 209.1 and 680.5) need to be carefully considered to ensure that the system includes the portion of the package that maintains the fissile material configuration. Water is specified as the reflector material in the Transport Regulations because of its relatively good reflective properties and its natural abundance. The specification of 20 cm of water is selected as a practical value (reflection from an additional 10 cm of water would add less than 0.5% in reactivity to an infinite slab of U-235) that represents nearly the worst reflection conditions typically found in transport. The assessment should consider the confinement system reflected by 20 cm of full density water and with the confinement system reflected by the surrounding material of the packaging. The situation that yields the highest neutron multiplication should be used as the basis for ensuring subcriticality. The reason that both situations need to be considered is that it is possible during routine loading operations, or after an accident, that the confinement system could be outside the packaging and reflected by water.

681.2. As a minimum, paras 681 and 682 require subcriticality with full water reflection of an individual package under routine, normal and accident conditions. Paragraph 680 is also required to be complied with, in respect of the presence of water inside the package. The competent authority may also require the subcriticality of inner packaging components together with the fissile material from an individual package and with full water reflection under routine conditions of transport. This is to cover scenarios where the inner packaging components together with the fissile material may be removed from the packaging, and would also apply to systems with multiple barriers.

682.1. The requirements for demonstrating subcriticality of an individual package are specified so as to determine the maximum neutron multiplication in both normal and accident conditions of transport. In the assessment, due account needs to be given to the results of the package tests required in paras 684(b) and 685(b) and the conditions under which the absence of water leakage may be assumed, as described in para. 680.

682.2. 'Subcritical' means that the maximum neutron multiplication, adjusted appropriately by including a calculational bias, uncertainties and a subcritical margin, should be less than 1.0. Recommendations on the assessment procedure and on determining an upper subcritical limit are provided in Appendix VI.

683.1. It is possible for accidents to be significantly more severe in transport by air mode than in surface transport modes. In recognition of this, more stringent requirements were introduced in the 1996 Edition of the Transport Regulations for packages designed for air transport of fissile material.

683.2. The requirements for packages transported by air specifically address the assessment of criticality of an individual package in isolation. Paragraph 683(a) requires a single package, with no water in-leakage, to be subcritical following the Type C test requirements of para. 734. This requirement is provided to preclude a rapid advance towards criticality that might arise from potential geometrical changes in a single package; thus, water in-leakage is not considered. Reflection conditions of at least 20 cm of water at full density are assumed as this provides a conservative approximation of reflection conditions likely to be encountered. Since water in-leakage is not assumed, only the package and contents need be considered with regard to the geometric condition of the package following the specified tests. Due credit may be taken in the specification of the geometric conditions in the criticality assessment for the condition of the package following the tests of para. 734(a) and (b) on separate specimens of the package. The conditions should be conservative but consistent with the results of the tests. Where the condition of the package following the tests cannot be demonstrated, worst case assumptions regarding the geometric arrangement of the package and the contents should be made, taking into account all moderating and structural components of the packaging. The assumptions should be in conformity with the potential worst case effects of the mechanical and thermal tests, and all package orientations should be considered for the analysis. Subcriticality needs to be demonstrated after due consideration of aspects such as the efficiency of the moderator, loss of neutron absorbers, rearrangement of packaging components and contents, geometric changes and temperature effects. Potential reactivity increases that might occur due to a loss of package moderator should be considered. When inadequate information is available on the package conditions subsequent to the Type C test requirements of para. 734, configurations demonstrated to provide conservative reactivity should be considered. Examples of configurations that might be considered are:

- (a) A spherical volume of package contents surrounded by 20 cm of water;
- (b) A spherical volume of package contents surrounded by packaging material and reflected by 20 cm of water;
- (c) A spherical mixture of package contents and packaging material surrounded by 20 cm of water.

Other, more conservative, examples may exist.

683.3. Paragraph 683(b) requires that, for an individual package, water leakage into or out of the package is addressed unless the multiple water barriers are demonstrated as being watertight following the tests of paras 733 and 734. Thus, for packages transported by air, in determining watertightness as required by para. 680(a), the tests of para. 685(b) are replaced by the tests of para. 683(b).

683.4. In summary, para. 683(a) provides an additional assessment for a package transported by air while para. 683(b) provides a supplement to para. 680(a) to be applied in the assessment of para. 682 for packages transported by air.

Assessment of package arrays under normal conditions of transport

684.1. The assessment requires that all arrangements of packages be considered in the determination of the number of five times N packages that is subcritical, because the neutron interaction occurring among the packages of the array might not be equal along the three dimensions.

684.2. The assessment might involve the calculation of large finite arrays for which there is a lack of experimental data. Therefore, a specific supplementary allowance should be made in addition to other margins usually allowed for random and systematic effects on calculated values of the neutron multiplication factor.

684.3. 'Subcritical' means that the maximum neutron multiplication, adjusted appropriately by including a calculational bias, uncertainties and a subcritical margin, should be less than 1.0. See Recommendations on the assessment procedure and on determining an upper subcritical limit are provided in Appendix VI.

684.4. After the water spray test, water might leak into a void space of the package. The quantity of water that has leaked should be taken into account to determine the maximum neutron multiplication factor of the package array.

Assessment of package arrays under accident conditions of transport

685.1. From the 1996 Edition of the Transport Regulations, tests for the accident conditions of transport included the crush test of para. 727(c) for lightweight (<500 kg) and low density (<1000 kg/m³) packages. The criteria for invoking the crush test, as opposed to the drop test of para. 727(a), are the same as those used for packages with contents (other than special form radioactive material) greater than 1000A₂ (see para. 659(b)).

685.2. Paragraph 685(c) provides a severe restriction on any fissile material permitted to escape the package under accident conditions. All precautions to preclude the release of fissile material from the containment system should be taken. The variety of configurations possible for fissile material escaping from the containment system and the possibility of subsequent chemical or physical changes produces the requirement that the total quantity of fissile material that escapes from the array of packages be less than the minimum critical mass for the fissile material type and with optimum moderator conditions and reflection by 20 cm of full density water. Moreover, neutron interactions between the escaped fissile material and the package array under accident conditions should be considered. An equal amount of material should be assumed to escape from each package in the array. The difficulty is in demonstrating the maximum quantity that could escape from the containment system. Depending on the packaging components that define the containment and confinement systems, it is possible for fissile material to escape the containment system, but not the confinement system. In such cases, there may be adequate mechanisms for criticality control. The intent of para. 685(c), however, is to ensure proper consideration of any potential escape of fissile material from the package in which loss of criticality control has to be assumed.

685.3. The assessment conditions considered should also include those arising from events less severe than the test conditions. For example, it is possible for a package to be subcritical following a 9 m drop but to be critical under conditions consistent with a less severe impact.

685.4. See paras 684.1–684.3.

685.5. After the immersion test, water might leak into a void space of the package. The quantity of water that has leaked should be taken into account to determine the maximum neutron multiplication factor of the package array.

Determination of criticality safety index (CSI) for packages

686.1. This paragraph establishes the procedure for obtaining the CSI of a package. The value of N used to determine the CSI is required be such that a package array based on this value would be subcritical

under the conditions of both paras 684 and 685. It would be wrong to assume that one condition would be satisfied if the other alone has been subjected to detailed analysis. The results of any one of the specified tests could cause a change in the packaging or contents that could affect the system moderation and/or the neutron interaction between packages, thus causing a distinct change in the neutron multiplication factor. Therefore, the limiting N number cannot be assumed to be that of normal conditions or accident conditions prior to an assessment of both conditions.

686.2. To determine the value of N for arrays under normal conditions of transport (see para. 684) and under accident conditions of transport (see para. 685), tentative values of N may be used. Any array of five times N packages, each under the conditions specified in para. 684(b), is required to be tested to see if it is subcritical, and any array of two times N packages, each under the conditions in para. 685(b), is required to be tested. If those arrays are subcritical, the selected value of N can be used for determining the CSI of the package. If the assessment indicates that the selected value of N does not yield a subcritical array under all required conditions, then N should be reduced and the assessments of paras 684 and 685 should be repeated to ensure subcriticality. Another, more thorough, approach is to determine the two values of N that separately satisfy the requirements of paras 684 and 685 and then use the smaller of these two values to determine the value of the CSI. This latter approach is considered more thorough because it provides a limiting assessment for each of the array conditions — normal and accident.

686.3. The CSI for a package, overpack or freight container should be rounded up to the first decimal place. For example, if the N number is 11, then $50/N$ is 4.5454 and that value should be rounded up to provide a CSI of 4.6. The CSI should not be rounded down. To avoid disadvantages by this rounding procedure, with the consequences that only a smaller number of packages can be transported (in the given example the number would be 10), the exact value of CSI may be used.

REFERENCES TO SECTION VI

- [1] GORDON, G., GREDINGH, R., Leach Test of Six 192-Iridium Pellets Based on the IAEA Special Form Test Procedures, AECB Rep. Info-0106, Atomic Energy Control Board, Ottawa (1981).
- [2] INTERNATIONAL ORGANIZATION FOR STANDARDIZATION, Radiological protection — Sealed radioactive sources — General requirements and classification, ISO 2919:2012, ISO, Geneva (2012).
- [3] INTERNATIONAL ORGANIZATION FOR STANDARDIZATION, Radiation Protection — Sealed Radioactive Sources — Leakage Test Methods, ISO 9978:1992(E), ISO, Geneva (1992).

- [4] ASTON, D., BODIMEADE, A.H., HALL, E.G., TAYLOR, C.B.G., The Specification and Testing of Radioactive Sources Designated as ‘Special Form’ Under the IAEA Transport Regulations, CEC Study Contract XVII/322/80.6, Rep. EUR 8053, CEC, Luxembourg (1982).
- [5] WOODCOOK, E.R., PAXTON, H.C., “The criticality aspects of transportation of fissile materials”, Progress in Nuclear Energy, Series IV, Vol. 4, Pergamon Press, Oxford and New York (1961) 401–430.
- [6] NUCLEAR REGULATORY COMMISSION, Exemption from Classification as Fissile Material, 10 CFR 71.15, US Government Printing Office, Washington, DC (2013).
- [7] PARKS, C.V., HOPPER, C.M., LICHTENWALTER, J., Assessment and Recommendations for Fissile-Material Packaging Exemptions and General Licenses Within 10 CFR Part 71, NUREG/CR-5342 (ORNL/TM-13607), Nuclear Regulatory Commission, Washington, DC (1998).
- [8] REICHE, I., KRÖGER, H., “Criticality calculations for uranium of various enrichments at low concentrations embedded in materials of low neutron absorption”, paper presented at Int. Conf. on Nuclear Criticality Safety, St. Petersburg, 2007.
- [9] COOKE, B., “Trunnions for spent fuel element shipping casks”, Packaging and Transportation of Radioactive Materials, PATRAM 89 (Proc. Int. Symp. Washington, DC, 1989), Oak Ridge Natl Lab., TN (1989).
- [10] AMERICAN NATIONAL STANDARDS INSTITUTE, American National Standard for Special Lifting Devices for Shipping Containers Weighing 10 000 Pounds (4,500 kg) or More for Nuclear Materials, Rep. ANSI N14.6-1978, ANSI, New York (1978).
- [11] KERNTECHNISCHER AUSSCHUSS, Load Attaching Points on Loads in Nuclear Power Plants, KTA 3905, KTA Geschäftsstelle, Bundesamt für Strahlenschutz, Salzgitter, Germany (2012).
- [12] SULLIVAN, G. J., STAHRMER, U. and FREEMAN, E. L., “Aging Management Assessment of Type B Transportation Packages”, 14th International Symposium on the Packaging and Transportation of Radioactive Materials (PATRAM 2004), Berlin, Germany, September 20-24, 2004
- [13] INTERNATIONAL ATOMIC ENERGY AGENCY, Methodology Guidance for Preparation of a Safety Case for a Dual Purpose Cask for Storage and Transport of Spent Fuel, IAEA-TECDOC-****, IAEA, Vienna (201*)
- [14] INTERNATIONAL ORGANIZATION FOR STANDARDIZATION, Nuclear Energy — Packaging of uranium hexafluoride (UF₆) for Transport, ISO 7195: 2005, ISO, Geneva (2005).

- [15] AMERICAN NATIONAL STANDARDS INSTITUTE, “Nuclear Materials – Uranium Hexafluoride – Packaging for Transport”, ANSI N14.1-2012, ANSI, New York (2012).
- [16] INTERNATIONAL CIVIL AVIATION ORGANIZATION, Technical Instructions for the Safe Transport of Dangerous Goods by Air, 2017–2018 Edition, ICAO, Montreal (2017).
- [17] UNITED NATIONS, Recommendations on the Transport of Dangerous Goods, Model Regulations, Twentieth Revised Edition (ST/SG/AC.10/1/Rev.20), UN, New York and Geneva (2017).
- [18] INTERNATIONAL ORGANIZATION FOR STANDARDIZATION, Series 1 Freight Containers — Specification and Testing — Part 3 Tank Containers for Liquids, Gases and Pressurized Dry Bulk, ISO 1496-3:1995, ISO, Geneva (1995) and subsequent Amendment 1:2006.
- [19] UNITED NATIONS ECONOMIC COMMISSION FOR EUROPE, INLAND TRANSPORT COMMITTEE, European Agreement Concerning the International Carriage of Dangerous Goods by Road (ADR), 2017 Edition, UNECE, New York and Geneva (2016).
- [20] INTERGOVERNMENTAL ORGANIZATION FOR INTERNATIONAL CARRIAGE BY RAIL (OTIF), Regulations Concerning the International Carriage of Dangerous Goods by Rail (RID), 2017 Edition, OTIF, Bern (2016).
- [21] INTERNATIONAL ORGANIZATION FOR STANDARDIZATION, Series 1 Freight Containers – Specifications and Testing – Part 1: General Cargo Containers for General Purposes, ISO 1496-1: 2013, ISO, Geneva (2013) and subsequent Amendment 1:2016.
- [22] INTERNATIONAL MARITIME ORGANIZATION, International Convention for Safe Containers, 1972 (CSC 1972), (2014 Edition), IMO, London (2014).
- [23] MALLET, A.J., ORGDP Container Test And Development Programme: Fire Tests of UF₆-Filled Cylinders, K-D-1984, Union Carbide Corp., Oak Ridge, TN (1966).
- [24] RINGOT, C., HAMARD, J., “The toxic and radiological risk equivalence approach in UF₆ transport”, UF₆ – Safe Handling, Processing and Transporting (Proc. Conf. Oak Ridge, TN, 1988), Oak Ridge Gaseous Diffusion Plant, TN (1988) 29–36.
- [25] BIAGGIO, A.L., LOPEZ VIETRI, J.R., “Uranium hexafluoride in transport accidents”, Packaging and Transportation of Radioactive Materials, PATRAM 86 (Proc. Int. Symp. Davos, 1986), IAEA, Vienna (1987) 381–387.
- [26] SAROUL, J., et al., “UF₆ transport container under fire conditions, experimental results”, Uranium Hexafluoride: Processing, Handling, Packaging, Transporting (Proc. 3rd Int. Conf. Paducah, KY, 1995), Institute of Nuclear Materials Management, Northbrook, IL (1995).
- [27] PINTON, E., DURET, B., RANCILLAC, F., “Interpretation of TEN2 experiments”, *ibid.*

- [28] WILLIAMS, W.R., ANDERSON, J.C., “Estimation of time to rupture in a fire using 6FIRE, a lumped parameter UF₆ cylinder transient heat transfer/stress analysis model”, *ibid.*
- [29] WATARU, M., et al., “Safety analysis on the natural UF₆ transport container”, *ibid.*
- [30] LYKINS, M.L., “Types of corrosion found on 10- and 14-ton mild steel depleted uranium UF₆ storage cylinders”, *ibid.*
- [31] BLUE, S.C., “Corrosion control of UF₆ cylinders”, *ibid.*
- [32] CHEVALIER, G., et al., “L’arrimage de colis de matières radioactives en conditions accidentelles”, *Packaging and Transportation of Radioactive Materials, PATRAM 86 (Proc. Int. Symp. Davos, 1986), IAEA, Vienna (1987).*
- [33] UNITED STATES ENRICHMENT CORPORATION, Reference USEC-651, USEC, Washington, DC (2006).
- [34] BRITISH STANDARDS INSTITUTE, *Guide to the Design, Testing and Use of Packaging for the Safe Transport of Radioactive Materials, BS 3895:1976, GR 9, BSI, London (1976).*
- [35] AMERICAN NATIONAL STANDARDS INSTITUTE, *American National Standard for Leakage Tests on Packages for Shipment of Radioactive Material, Rep. ANSI N14.5-2014, ANSI, New York (2014).*
- [36] INTERNATIONAL ORGANIZATION FOR STANDARDIZATION, *Safe Transport of Radioactive Material — Leakage Testing on Packages, ISO 12807:2018(E), ISO, Geneva (2018).*
- [37] HOLMAN, J.P., *Heat Transfer, 7th edn, McGraw Hill, New York (2009).*
- [38] MACDONALD, H.F., “Individual and collective doses arising in the transport of irradiated nuclear fuels”, *Pack aging and Transportation of Radioactive Materials, PATRAM 80 (Proc. Int. Symp. Berlin, 1980), Bundesanstalt für Materialprüfung, Berlin (1980).*
- [39] GOLDFINCH, E.P., MACDONALD, H.F., *Dosimetric aspects of permitted activity leakage rates for Type B packages for the transport of radioactive materials, Radiat. Prot. Dosim. 2 (1982) 75.*
- [40] MACDONALD, H.F., *Radiological Limits in the Transport of Irradiated Nuclear Fuels, Rep. TPRD/B/0388/N84, Central Electricity Generating Board, Berkeley, UK (1984).*

- [41] EUROPEAN COMMISSION, FOOD AND AGRICULTURE ORGANIZATION OF THE UNITED NATIONS, INTERNATIONAL ATOMIC ENERGY AGENCY, INTERNATIONAL LABOUR ORGANIZATION, OECD NUCLEAR ENERGY AGENCY, PAN AMERICAN HEALTH ORGANIZATION, UNITED NATIONS ENVIRONMENT PROGRAMME, WORLD HEALTH ORGANIZATION Radiation Protection and Safety of Radiation Sources: International Basic Safety Standards, IAEA Safety Standards Series No. GSR Part 3, IAEA, Vienna (2014).
- [42] MACDONALD, H.F., GOLDFINCH, E.P., The Q System for the Calculation of A₁ and A₂ Values within the IAEA Regulations for the Safe Transport of Radioactive Materials, Rep. TPRD/B/0340/R83, Central Electricity Generating Board, Berkeley, UK (1983).
- [43] UNITED KINGDOM ATOMIC ENERGY AUTHORITY, Shielding Integrity Testing of Radioactive Material Transport Packaging, Gamma Shielding, Rep. AECF 1056, Part 1, UKAEA, Harwell (1977).
- [44] UNITED KINGDOM ATOMIC ENERGY AUTHORITY, Testing the Integrity of Packaging Radiation Shielding by Scanning with Radiation Source and Detector, Rep. AESS 6067, UKAEA, Risley (1977).
- [45] AMERICAN NATIONAL STANDARDS INSTITUTE, American National Standard for Program for Testing Biological Shielding in Nuclear Reactor Plants, Rep. ANSI N18.9-1972, ANSI, New York (1972).
- [46] JANARDHANAN, S., et al., “Testing of massive lead containers by gamma densitometry”, Industrial Isotope Radiography (Proc. Nat. Symp.), Bharat Heavy Electrical Ltd, Tiruchirapalli, India (1976).
- [47] KRISHNAMURTHY, K., AGGARMAL, K.S., “Complementary role of radiometric techniques in radiographic practice”, *ibid*.
- [48] NAGAKURA, T., MAKI, Y., TANAKA, N., “Safety evaluation on transport of fuel at sea and test program on full scale cask in Japan”, Packaging and Transportation of Radioactive Materials, PATRAM 78 (Proc. Int. Symp. New Orleans, 1978), Sandia Natl Labs, Albuquerque, NM (1978).
- [49] HEABERLIN, S.W., et al., Consequences of Postulated Losses of LWR Spent Fuel and Plutonium Shipping Packages at Sea, Rep. BNWL-2093, Battelle Pacific Northwest Lab., Richland, WA (1977).
- [50] INTERNATIONAL ATOMIC ENERGY AGENCY, Severity, probability and risk of accidents during maritime transport of radioactive material - Final report of a coordinated research project 1995–1999, IAEA-TECDOC-1231, IAEA, Vienna (2001).
- [51] HIGSON, J., VALLEPIN, C., KOWALEVSKY, H., “A review of information on flow equations for the assessment of leaks in radioactive transport containers”, Packaging and Transportation of Radioactive Materials, PATRAM 89 (Proc. Int. Symp. Washington, DC, 1989), Oak Ridge Natl Lab., TN (1989).

- [52] BURNAY, S.G., NELSON, K., “Leakage of transport container seals during slow thermal cycling to -40°C ”, *Int. J. Radioact. Mater. Transp.* **2** (1991).
- [53] JAPAN ATOMIC ENERGY RESEARCH INSTITUTE, *Nuclear Criticality Safety Handbook*, Nihon Shibou, Science and Technology Agency (1988) (in Japanese). [English Translation: JAERI-Review 95-013, JAERI, Tokyo (1995)].
- [54] COMMISSARIAT À L'ÉNERGIE ATOMIQUE, *Guide de Criticité*, Rep. CEA-R-3114, CEA, Paris (1967).
- [55] INTERNATIONAL ATOMIC ENERGY AGENCY, *Application of the Revised Provisions for Transport of Fissile Material in the IAEA Regulations for the Safe Transport of Radioactive Material – 2012 Edition*, IAEA-TECDOC-1768, IAEA, Vienna (2015).
- [56] DARBY, S., BARTON, N., NUTTALL, M., MENNERDAHL, D., “Fissile Exceptions — A General Scheme for Package Based on CSI Control”, *Packaging and Transportation of Radioactive Materials, PATRAM 2010* (Proc. Int. Symp. London, 2010, Department for Transport, UK (2010).
- [57] ITO, D., et. al., “Investigation of criticality effects of deuterium and beryllium in package containing fissile material”, *J. Nucl. Sci. Technol.* **44** 6 (2007) 869–874.
- [58] PARKS, C.V., HOPPER, C.M., LICHTENWALTER, J., *Assessment and Recommendations for Fissile-Material Packaging Exemptions and General Licenses Within 10 CFR Part 71*, NUREG/CR-5342 (ORNL/TM-13607), Appendix C, D and E, Nuclear Regulatory Commission, Washington, DC (1998).
- [59] DESNOYERS, B., “Radioactive waste and fissile exceptions”, *Packaging and Transportation of Radioactive Materials, PATRAM 2010* (Proc. Int. Symp. London, 2010), Department for Transport, London (2010).
- [60] BARTON, N.J., WILSON, C.K., *Review of fissile exception criteria in IAEA regulations*”, *Nuclear Criticality Safety, ICNC '95* (Proc. 5th Int. Conf. Albuquerque, NM, 1995), Vol. 2, Univ. of New Mexico, Albuquerque, NM (1995) 915–972.
- [61] TAKANO, M., OKUNO, H., *OECD/NEA Burnup Credit Criticality Benchmark, Results of Phase IIA*, Rep. NEA/NSC/DOC(96)01, Japan Atomic Energy Research Institute, Tokyo (1996).
- [62] DeHART, M.D., PARKS, C.V., “Issues related to criticality safety analysis for burnup credit applications”, *Nuclear Criticality Safety, ICNC'95* (Proc. 5th Int. Conf. Albuquerque, NM, 1995), Univ. of New Mexico, Albuquerque, NM (1995) 26–36.
- [63] BOWDEN, R.L., THORNE, P.R., STRAFFORD, P.I., “The methodology adopted by British Nuclear Fuels plc in claiming credit for reactor fuel burnup in criticality safety assessments”, *ibid.*, pp. 1B.3–10.

- [64] PARKS, C.V., GAULD, I.C., MUELLER, D.E., WAGNER, J.C., “Development of technical basis for burnup credit regulatory guidance in the United States”, Packaging and Transportation of Radioactive Materials, PATRAM 2010 (Proc. Int. Symp. London, 2010), Department of Transport, London (2010).
- [65] AMERICAN SOCIETY FOR TESTING AND MATERIALS, Standard Specification for Uranium Hexafluoride Enriched to Less than 5% U-235, ASTM C996-90, ASTM, Philadelphia, PA (1991).

Section VII

TEST PROCEDURES

DEMONSTRATION OF COMPLIANCE

701.1. The requirements in the Transport Regulations represent performance standards, as opposed to specific design requirements. While this means greater flexibility for the designer, it presents more difficulties in obtaining approval. The intent is to allow the applicant to use accepted engineering practice to evaluate a package or a radioactive material (e.g. special form radioactive material). This could include the testing of full scale packages, scale models, mock-ups of specific parts of a package, calculations and reasoned arguments, or a combination of these methods. Regardless of the methods used, documentation should be sufficiently complete and proper to satisfy the competent authority that all required safety aspects and modes of failure have been considered. Any assumption should be clearly stated and fully justified.

701.2. Testing packages containing radioactive material presents a special challenge because of the radiation hazard. While it may not be advisable to perform the tests required using radioactive material, it is necessary to convince the competent authority that the regulatory requirements have been met. When determining whether radioactive material is to be used in the tests, a radiological safety assessment should be made.

701.3. Many other factors should be considered in demonstrating compliance. These include, but are not limited to, the complexity of the package design, special phenomena that require investigation, the availability of facilities, and the ability to accurately measure responses to testing and/or to evaluate the influence of scaling.

701.4. Where the Transport Regulations require compliance with a specific leakage limit, the designer should incorporate some means in the design of readily demonstrating the required degree of leaktightness. One method is to include some type of sampling chamber or test port that can be readily checked before shipment.

701.5. Test models should accurately represent the intended design, with manufacturing methods and a management system similar to that intended for the finished product. Increased emphasis should be placed on the prototype in order to ensure that a test specimen is a true representation of the product. If simulated radioactive contents are being used, these contents should truly represent the actual contents in mass, mechanical stiffness, density, chemical composition, volume and any other characteristics that are significant. The contents should simulate any impact loads on the inside surface of the package and any closure lids including internal collision effects in the case of contents that are not fixed in place. The intensity of internal collisions under likely incidents or accidents depends in particular on the initial gaps between the contents and the envelope structure. Therefore, the most damaging position of contents within the package cavity should be considered, either simulated directly in drop test or suitably incorporated in structural analysis [1, 2]. Any deficiencies or differences in the model should be documented before testing, and some evaluation should be done to determine how these may affect the outcome of the tests, either positively or negatively.

701.6. The number of specimens used in testing will be related to the design features to be tested and to the desired reliability of the assessments. Repetition of tests with different specimens may be used to take into account variations due to the range of properties in the material specifications or tolerances in the design.

701.7. The results of the tests may necessitate an increase in the number of specimens in order to meet the requirements of the test procedures in respect of maximum damage. It may be possible to use computer code simulations to reduce the number of tests required.

701.8. Care has to be exercised when planning the instrumentation and analysis of either a scale model test or a full scale test. It should be ensured that adequate and correctly calibrated instrumentation and test devices are provided. The instrumentation, test devices and electrical connections should not interfere in a way that would invalidate the test results. Test conditions and results should be documented and validated.

701.9. When acceleration sensors are used to evaluate the impact behaviour of the package, the cut-off frequency should be considered. The cut-off frequency should be selected to suit the structure (shape and dimensions) of the package. For initial consideration for a package with a mass of 100 tonnes with impact limiter, the cut-off frequency could be 100–200 Hz, and for smaller packages this cut-off frequency should be multiplied by a factor $(100/m)^{1/3}$, where m is the mass of the package in tonnes. This initial consideration should be verified. When the package includes components necessary to guarantee the safety under impact, and these components have a fundamental resonance or first mode frequencies exceeding the cut-off frequency, the cut-off frequency may need to be adjusted so that the eliminated part of the signal has no significant influence on the assessment of the mechanical behaviour of these components. In these cases, a modal analysis may be necessary. Examples of such components include shells under evaluation for brittle fracture and internal arrangement structures needed for guaranteeing subcriticality. When such an issue is dealt with in an analytical evaluation, the calculation method and modelling should allow a pertinent assessment of these dynamic effects. This may require adjustment of the time steps and mesh size to low values consistent with the frequencies used in the calculation.

701.10. In many cases, it may be simpler and less expensive to test a full scale model rather than to use a scale model or demonstrate compliance by calculation and reasoned argument. One disadvantage in relying completely on testing is that any future changes to either the contents or the package design may be much harder or impossible to justify. On a practical basis, unless the packages are very inexpensive to construct and several are tested, it usually requires additional work to justify the test attitude.

701.11. In considering reference to previously satisfactory demonstrations of a similar nature, all the similarities and differences between the two packages should be considered. The areas of difference may require modification of the results of the demonstration. The ways and the extent to which the differences and similarities will qualify the results from the previous demonstration depend upon their effects. In an extreme case, a packaging may be geometrically identical with that used in an approved package but because of material changes in the new packaging, the reference to the previous demonstration would not be relevant and hence should not be used.

701.12. Another method of demonstrating compliance is by calculation, or reasoned argument, when the calculation procedures and parameters are generally agreed upon to be reliable or conservative. Regardless of the qualification method chosen, there will probably be a need to carry out some calculations and reasoned argument. Material properties in specifications are usually supplied to yield a probability of not being under strength of between 95% and 98%. When tests are used for determining material property data, the scatter in the data should be taken into account. It is also necessary to consider data scatter due to material and manufacturing tolerances unless all calculations are based on the worst combination of possible dimensions. When computer codes are used, it should be made clear that the formulations used are applicable to finite deformation (i.e. not only large displacement but also large strain). In most cases, the tests, especially those involving accidental impact, will necessitate a finite strain formulation owing to the potentially severe damage inflicted. Ignoring such details could lead to

significant error. Any reasoned arguments should be based on engineering experience. Where theory is used, due account should be taken of design details that could modify the result of general theory, for example, discontinuities, asymmetries, irregular geometry, inhomogeneities or variable material properties. The presentation of reasoned argument based on subjective material should be avoided.

701.13. Many calculations could require the use of commercially available computer codes. The reliability and the appropriate validation of the computer code selected should be considered. First, is the code applicable for the intended calculation? For example, for mechanical assessments, can it accept impact calculations? Is it suitable for calculating plastic as well as elastic deformations? Second, does the computer code adequately represent the packaging under review for the purpose of compliance? To meet these two criteria, it may be necessary for the user to run 'benchmark' problems, which use the code to model and calculate the parameters of a problem in which the results are known. Options settings may have a strong influence on the validity of the benchmark studies to the problem being solved. In mechanical codes, options and modelling considerations include package material properties under dynamic conditions, elastic and plastic deformations, detailing connections between components such as screws and welds, and allowing for friction, hydrodynamic, sliding and damping effects. User experience in the proper selection of code options, material properties and mesh selection can affect the results. Benchmark studies should also consider the sensitivity of the results to parameter variation. Confidence can be increased by systematic benchmarking, proceeding from the simple to the complex. For other uses, checks that the input and output balances in load or energy may be necessary. When the code used is not widely employed and known, proof of the theoretical correctness should also be given.

701.14. Demonstration of compliance may be done by tests with models of appropriate scale incorporating features significant with respect to the item under investigation, and when engineering experience has shown results of such tests to be suitable for design purposes. When a scale model is used, the need to adjust certain test parameters, such as penetrator diameter or compressive load, should be taken into account. However, certain test parameters cannot be adjusted — for example, time and gravitational acceleration — and therefore it will be necessary to adjust the results by use of scaling factors. Scale modelling should be supported by calculation or by computer simulation using benchmarked computer software to ensure that an adequate margin of safety exists.

701.15. When scale models are used to determine damage, due consideration should be given to the mechanisms affecting energy absorption, since friction, rupture, crushing, elasticity, plasticity and instability may have different scale factors as a result of different parameters in the test being performed. Also, since the demonstration of compliance requires the combination of three tests (such as penetration, drop and thermal tests for Type B(U) and Type B(M) packages), conflicting criteria for the test parameters may require a compromise, which, in turn, would give results that require scale factoring. In summary, the effect of scaling for all areas of difference should be considered.

701.16. Experience has shown that the testing of scale models may be very useful for demonstrating compliance with certain specific requirements of the Transport Regulations, particularly mechanical tests. Attempts to perform thermal tests using scale models are problematic (see paras 728.23 and 728.24). In mechanical tests, the conditions of similitude are relatively simple to create, provided that the same materials and suitable methods of construction are used for the model as for the full sized package (see para. 701.17). Thus, in an economical manner, it is possible to study the relationship between package orientation and the resulting damage and the overall deformation of the package, and to obtain information concerning the deceleration of package parts. In addition, many design features can be optimized by model testing.

701.17. The details that should be included in the model are a matter of judgement and depend on the type of test for which the model is intended. For example, in the determination of the structural response

from an end impact, the omission of lateral cooling fins from the scale model may result in more severe damage. This type of consideration may simplify construction of the model without detracting from its validity. Only pertinent structural features that might influence the outcome of the test need be included. It is essential, however, that the materials used for construction of the scale model and the full sized package are the same and that suitable construction and manufacturing techniques are used. In this sense, the construction and manufacturing techniques that will replicate the mechanical behaviour and structural response of the full sized package should be used, giving consideration to such processes as machining, welding, heat treatment and bonding. The stress–strain characteristics of the construction materials should not be dependent on the strain rate to a point that would invalidate the model results. This point needs to be emphasized because the strain rates in the model may be higher than in the full sized package.

701.18. In some cases, it may not be practical to scale all components of the package precisely. For example, consider the thickness of an impact limiter compared with the overall length of the package. In the model, the ratio of thickness to overall length may differ from that of the actual package. Other examples include sheet metal gauge, gasket or bolt size that may not be a standard size or may not be readily available. When any appreciable geometrical discrepancy exists between the actual package and the model to be tested, the behaviour of both when subjected to the 9 m drop test should be compared by computer code analysis to determine whether the effect of geometrical discrepancy is a significant consideration. The computer code employed should have been verified through appropriate benchmark tests. If the effects of the discrepancies are not significant, the model could be considered suitable for a scale model drop test. This applies to a 1:4 scale model or a larger model.

701.19. The scale factor chosen for the model is another area where a judgement needs to be made, since the choice of scale factor depends on the accuracy necessary to ensure an acceptable representation of the full scale package. The greater the deviation from full scale, the greater the error that is introduced. Consequently, the reduction of scale might be greater for a study of package deformation as a whole than for testing certain parts of the package, and in some cases, the scale factor chosen may be determined by the particular type of test being undertaken. In some tests, such as the penetration test, the drop II of the mechanical test and the puncture/tearing test, specified in paras 727(b) and 735 of the Transport Regulations, the bar or the probe should be scaled. In other cases, where the packaging may be protected by a significant thickness of deformable structure or where significant deformation of the puncture bar can occur, the drop height may need to be corrected [3, 4]. The correction should take into account the additional potential energy of the package as a result of the motion of its centre of gravity over the impact time. The drop height correction is of concern for both the drop I (9 m) test and drop II (1 m punch) test, but it is generally more significant for the drop II test.

701.20. In general, a 1:4 scale model or a larger model should be used. For such a model, the effect of strain rate dependence on the material's mechanical properties will be negligible. The effect of strain rate dependence for typical materials (e.g. stainless steel) should be checked.

701.21. Scaling of drop tests is possible (with consideration of paras 701.22-701.25) as a result of the following model laws, which are valid if the original drop height is maintained, the original and the model have the same material properties and the package and/or puncture bar deformation is negligible relative to drop height:

Accelerations: $a_{\text{model}} = (a_{\text{original}})/M$

Forces: $F_{\text{model}} = (F_{\text{original}})M^2$

Stresses: $\sigma_{\text{model}} = \sigma_{\text{original}}$

Strains: $\epsilon_{\text{model}} = \epsilon_{\text{original}}$

Where M is the scale ratio (i.e. the ratio of the model dimension to the full size package)

701.22. For lightweight models, the model attitude or velocity during drop testing could be affected by such things as the swing of an ‘umbilical cord’ carrying wires for acceleration sensors or strain gauges, or by wind effects. Experience suggests that, for packages with masses up to 1000 kg, full scale models should be used for the test; otherwise special guides should be used with the lightweight scale models.

701.23. When an application for approval of a package design is based to any extent on scale model testing, the application should include a demonstration of the validity of the scaling methods used. Such a demonstration should include:

- (a) Definition of the scale factor;
- (b) Demonstration that the model constructed reproduces, sufficiently accurately, the details of the package or packaging parts to be tested;
- (c) A list of parts or features not reproduced in the model;
- (d) Justification for deletion of parts or features in the model;
- (e) Justification of the similitude criteria used.

701.24. In the evaluation of the results of a scale model test, the damage sustained by the packaging should be considered. In some cases, the damage to the package contents should also be considered, in particular when it involves a change in:

- (a) Release rate potential;
- (b) Parameters affecting criticality;
- (c) Shielding effectiveness;
- (d) Thermal behaviour.

701.25. It might be difficult to extrapolate the results of scale model testing involving seals and sealing surfaces to the responses expected in a full sized package. Although it is possible to acquire valuable information on the deformation and displacement of sealing surfaces with scale models, extrapolation of seal performance and leakage should be approached with caution (see para. 716.7). When scale models are used to test seals, the possible effect of factors such as surface roughness, seal behaviour as a function of material thickness and type, and the problems associated with predicting leakage rates on the basis of scale model results should be considered.

702.1. Any post-test assessment method used to ensure compliance should incorporate the following techniques, as appropriate to the type of package under examination:

- (a) Visual examination;
- (b) Assessment of distortion;
- (c) Seal gap measurements of all closures;

- (d) Seal leakage testing;
- (e) Destructive and non-destructive testing and measurement;
- (f) Microscopic examination of damaged material.

702.2. In the evaluation of damage to a package after a drop test, all damage from secondary impacts should be considered, except in the case of the accident condition of transport drop test II, whose purpose is limited to demonstrating package performance against local impact (see para. 727.16). Secondary impact includes all additional impacts between the package and target, following the initial impact. For evaluations based on numerical methods, it is also necessary to consider secondary impacts. Accordingly, the attitude of the package that produces the maximum damage should be determined with secondary as well as initial impacts taken into account. Experience suggests that the effect of secondary impact is often more severe for slender and rigid packages, including:

- (a) A package with an aspect ratio (length to diameter) larger than 5, but sometimes even as low as 2;
- (b) A large package when significant rebound is expected to occur following the 9 m drop;
- (c) A package in which the contents are rigid and slender and particularly vulnerable to lateral impacts.

TESTS FOR SPECIAL FORM RADIOACTIVE MATERIAL

General

704.1. The impact, percussion, bending and heat tests are intended to simulate the mechanical and thermal effects to which special form radioactive material might be exposed if released from its packaging.

704.2. Following each test listed in para. 704.1, the specimen is required to be subjected to a leaching assessment or a volumetric leakage test to ensure that special form radioactive material that becomes immersed in liquid as a result of an accident will meet the criteria in para. 603.

704.3. The tests of a capsule design may be performed with simulated radioactive material. The term 'simulated' means a facsimile of a radioactive sealed source, the capsule of which has the same construction and is made with the same materials as those of the sealed source that it represents but that contains, in place of the radioactive material, a substance with mechanical, physical and chemical properties as close as possible to those of the radioactive material and containing radioactive material in tracer quantities only. The tracer should be in a form that is soluble in a solvent that does not attack the capsule, in accordance with ISO 2919 [5]. When possible, short lived radionuclides should be used. However, if leaching assessment techniques are used, care needs to be taken when interpreting the results. The effects of scaling will have to be considered, the importance of which will depend upon the maximum activity to be contained within the capsule and the physical form of the intended capsule contents, particularly the solubility of the intended capsule contents as compared with that of the tracer radionuclide. These problems can be avoided if volumetric leakage tests are used (see paras 603.3 and 603.4). Typically, tests for special form radioactive material are performed on full scale sealed sources or indispersible solid material because they are not expensive and the results of the tests are easy to interpret.

Test methods

705.1. Since this test is intended to be analogous to the Type B(U) package 9 m drop test (see para. 603.1), the specimen should be dropped so as to suffer maximum damage.

706.1. Special attention should be paid to the percussion test conditions in order to get the required maximum damage.

706.2. In the case of percussion tests performed with specimens at temperatures higher than the ambient temperature, special precautions should be taken so as not to overheat and soften the lead sheet.

709.1. It is recognized that the tests indicated in paras 705, 706 and 708 are not unique and that other internationally accepted test standards may be equally acceptable. Two tests prescribed by the ISO have been identified as adequate alternatives for radioactive material enclosed in a sealed capsule.

709.2. The alternative test described in para. 709(a) is the ISO 2919 [5] Class 4 impact test for special form radioactive material with a mass of less than 200 g and the ISO 2919 [5] Class 5 Impact test for special form radioactive material with a mass of more than 200 g but less than 500 g. They consist of the following: the specimen is placed on a steel anvil and a hammer is dropped onto the specimen from a height of 1 m. The hammer has a mass of 2 kg for Class 4 and 5 kg for Class 5, and its flat striking surface has a diameter of 25 mm, with its edge rounded to a radius of 3 mm. The anvil has a mass of at least 20 kg for Class 4 and at least 50 kg for Class 5, and has a flat surface large enough to take the whole of the specimen. The anvil is required to be rigidly mounted. These tests may be employed in place of both the impact test (para. 705) and the percussion test (para. 706).

709.3. In the case of the alternative tests proposed in para. 709(a), the orientation of the specimen should be chosen to cause maximum damage.

709.4. The alternative test proposed in para. 709(b) is the ISO 2919 [5] Temperature Class 6 test, which consists of subjecting the specimen to a minimum temperature of -40°C for 20 min and heating over a period not exceeding 70 min from ambient to 800°C ; the specimen is then held at 800°C for 1 h, followed by thermal shock treatment in water at 20°C .

Leaching and volumetric leakage assessment methods

711.1. The leaching assessment is similar to the method applied to indispersible solid material (see para. 710) except that the specimen is not initially immersed in water for seven days. The other steps, however, remain the same.

711.2. The alternative volumetric leakage assessment as specified in para. 711(b) comprises any of the tests prescribed in ISO 9978 [6] that are acceptable to the competent authority. The tests generally allow for a reduction in the test period and, in addition, some of these tests are for non-radioactive substances. The volumetric leakage assessment option provides for a reduction in the time involved in the entire sequence of testing and may include a reduction in the period of time for using a shielded cell during the test. Therefore, the volumetric leakage assessment option could result in considerable cost reduction.

TESTS FOR LOW DISPERSIBLE RADIOACTIVE MATERIAL (LDRM)

712.1. LDRM is required to meet the same performance criteria for impact and fire resistance as a Type C package without producing significant quantities of dispersible material.

712.2. For LDRM, three tests are required: the 90 m/s impact test on to an unyielding target, the enhanced thermal test and the leaching test. The impact and thermal tests are non-sequential. For the leaching test, the material is required to be in a form representative of the material properties following any of the tests required by para. 605(b). The tests used to demonstrate the performance of LDRM do not have to be performed with the entire package contents if the results obtained with a representative fraction of the package contents can be properly scaled up to the full package contents. This is, for

example, the case if the package contents consist of several identical items, and it can be shown that multiplying the release established for one such item by the total number of such items in a package gives an upper estimate of the release from the entire contents of the package. For large items, it is also possible to perform tests with just an essential part of the item, or with a scale, as long as it is established how the test results obtained in this way can be extrapolated to the release behaviour of the entire contents of the package.

712.3. The 90 m/s impact test requires that the impact of the entire package contents, unprotected by the packaging, on to an unyielding target with a speed of at least 90 m/s leads to a release of airborne radioactive material in gaseous or particulate form up to 100 µm aerodynamic equivalent diameter of less than 100A₂. The aerodynamic equivalent diameter of aerosol particles can be determined by a variety of aerosol measuring instruments and techniques, such as impactors, optical particle counters and centrifugal separators (cyclones). Various experimental test procedures may be used. One possible approach is to impact a horizontally flying test specimen on to a vertical wall that has the required unyielding target attributes. All particulate matter with an aerodynamic equivalent diameter below 100 µm that becomes airborne can be transported upward by an upward directed airstream of appropriate speed and then analysed in accordance with particle size by established aerosol measurement techniques. An airstream with an upward speed of about 30 cm/s would serve as a separator, in that particles with an aerodynamic equivalent diameter < 100 µm would remain airborne, whereas larger particles would be removed (i.e. because their settling velocity exceeds 30 cm/s).

712.4. See paras 605.5, 605.7–605.9 and 704.3 for additional information.

TESTS FOR PACKAGES

Preparation of a specimen for testing

713.1. Unless the actual condition of the specimen had been recorded in advance of the test, it would be difficult to decide subsequently whether any defect was caused by the tests.

714.1. Since, in certain cases, components forming a containment system may be assembled in different ways, it is essential for test purposes that the specimen and the method of assembly be clearly defined.

Testing the integrity of the containment system and shielding, and assessing criticality safety

716.1. In order to establish the performance of specimens that have been subjected to the tests specified in paras 719–733, it may be necessary to undertake an investigation programme involving both inspection and further subsidiary testing. Generally, the first step will be a visual examination of the specimen and recording by photography. In addition, other inspections may be necessary. If the tests were performed with specimens containing radioactive trace material, wipe tests may give a measurement of the leakage. Leaktightness may be evaluated by following the procedures outlined in paras 648.3–648.5 (Type IP, Type A, Type B(U), Type B(M)). Likewise, the shielding integrity may be evaluated by using trace radiation material placed inside the packaging. After examination of the outer integrity, the containment system should be disassembled to check the situation in the interior: the integrity of capsules, glass, flasks; the stability of geometrical compartments, particularly where the intended contents are fissile material; the distribution of absorbent material; the stability of shielding and the function of mechanical parts. The investigatory programme should be aimed at examining three specific areas:

- (a) Integrity of the containment system;
- (b) Integrity of shielding;

- (c) Assurance, where applicable, that no rearrangement of the fissile contents or neutron poison or degree of moderation has adversely influenced the assumptions and predictions of the criticality assessment.

716.2. The integrity of the containment system can be evaluated in many ways. For example, the radioactive release from the containment system can be calculated on the basis of the volumetric (e.g. gaseous) release.

716.3. In the case of test specimens representative of full sized containment systems, direct leakage measurements can be made on the specimens.

716.4. After the tests, the following areas need attention:

- (a) The performance of the closure system;
- (b) The leakage that may have occurred elsewhere in the containment system.

716.5. Containment, in accordance with the Transport Regulations, involves so many variables that a single standard test procedure is not feasible.

716.6. Acceptable leakage test methods in ANSI N14.5 [7], listed in order of increasing sensitivity under usual conditions, include:

- (a) Gas pressure drop;
- (b) Water immersion bubble or soap bubble;
- (c) Ethylene glycol;
- (d) Gas pressure rise;
- (e) Vacuum air bubble;
- (f) Halogen detector;
- (g) Helium mass spectrometer.

716.7. Ref. [7] also:

- (a) Relates the regulatory requirements for containment of radioactive material to practical detectable mass flow leakage rates;
- (b) Defines the term 'leaktight' in terms of a volumetric flow rate;
- (c) Makes some simplifying, conservative assumptions so that many of the variables can be consolidated;
- (d) Describes a release test procedure;
- (e) Describes specific volumetric leakage tests.

716.8. ISO 12807 [8] specifies gas leakage test criteria and tests methods for demonstrating that Type B(U) and B(M) packages comply with the containment integrity requirements of the Transport

Regulations for design, fabrication, pre-shipment and periodic verifications. Preferred leakage test methods described by ISO 12807 [8] include:

(a) Quantitative methods:

- Gas pressure drop;
- Gas pressure rise;
- Gas filled envelope gas detector;
- Evacuated envelope gas detector;
- Evacuated envelope with back pressurization.

(b) Qualitative methods:

- Gas bubble techniques;
- Soap bubble;
- Tracer gas sniffer technique;
- Tracer gas spray method.

716.9. Ref. [8] is mainly based on the following assumptions:

- (a) Radioactive material could be released from the package in liquid, gas, solid, liquid with solids in suspension or particulate solid in a gas (aerosol) forms, or in any combination of such forms.
- (b) A radioactive release or leakage can occur by one or more of the following ways: viscous flow, molecular flow or permeation.
- (c) The rate of release of radioactive contents is measured indirectly by an equivalent gas leakage test that measures (non-radioactive) gas flow rates.
- (d) Release rates can be related mathematically to the diameter of a single straight capillary that in most cases is considered to represent, conservatively, a leak or leaks.

716.10. The main steps considered in Ref. [8] for determining leakage in both normal and accident conditions of transport are the following:

- (a) Determination of permissible radioactive release rates;
- (b) Determination of standardized leakage rates;
- (c) Determination of permissible test leakage rates for each verification stage;
- (d) Selection of appropriate test methods;
- (e) Performance of tests and records of results.

716.11. If specimens less than full size have been used for test purposes, direct measurement of leakage past seals may not be advisable as not all the parameters associated with leakage past seals are readily

scaled. In this instance, because loss of sealing is often associated with loss of seal compression resulting from, for example, permanent extension of the closure cover bolts, it is recommended that detailed measurements are made to establish the extent to which bolt extension and distortion of the sealing faces has occurred on the test specimen following the mechanical tests. The data based on detailed measurements may be scaled and the equivalent distortion and bolt extension at full size determined. From tests with full sized seals and using the scaled metrology data, the performance of the full size package may be determined.

716.12. With regard to evaluating shielding integrity, if a radioactive source is to be used to establish the post-accident test condition, any damage or modification to the post-test package configuration caused by the insertion of the source might invalidate the results obtained.

716.13. If a full size specimen has been used for testing, one method of proving the integrity of the shielding is to place a suitable source inside the specimen and inspect the entire surface of the specimen using X ray film or an appropriate radiation detector to determine whether there has been a loss of shielding. If there is evidence of loss of shielding at any point on the surface of the specimen, the dose rate should be determined by both actual measurement and calculation to ensure compliance with paras 648, 653, 659 and 671. For additional information, see paras 648.1–648.5 and 659.14–659.19.

716.14. Alternatively, a careful dimensional survey could be made of those parameters that contribute to shielding performance to ascertain that they have not been adversely affected, for example, by slumping or loss of lead from shields, that might give rise to either a general increase in radiation or increased localized dose rates.

716.15. The tests may demonstrate that the assumptions used in the criticality safety assessment are not valid. A change in the geometry or in the physical or chemical form of the packaging components or contents could affect the neutron interaction within or between packages, and any change should be consistent with the assumptions made in the criticality safety assessment required by paras 673–685. If the conditions after the tests are not consistent with the assumptions of the criticality safety assessment, the assessment may need to be modified.

716.16. Although the testing of the package at full or smaller scale can be carried out with simulated contents from which some data on the behaviour of any basket or skip used for positioning the contents can be obtained, the final geometry will, in practice, depend upon the interaction of the actual material (whose mechanical properties may be different from the simulated contents) with both the basket or skip and the other components of the packaging.

Target for drop tests

717.1. The target for drop tests is specified as an essentially unyielding surface. This unyielding surface is intended to cause damage to the package that would be equivalent to, or greater than, that anticipated for impacts on to actual surfaces or structures that might occur during transport. The specified target also provides a method for ensuring that analyses and tests can be compared and if necessary, accurately repeated. The unyielding target, even though described in general terms, can be repeatedly constructed to provide a relatively large mass and stiffness with respect to the package being tested. So-called ‘real’ targets, such as soil, soft rock and some concrete structures, are less stiff and could cause less damage to a package for a given impact velocity [9]. In addition, it is more difficult to construct yielding surfaces that give reproducible test results, and the shape of the object being dropped can affect the yielding character of the surface. Thus, if yielding targets were used, the uncertainty of the test results would increase, and the comparison between calculations and tests would be much more difficult.

717.2. One example of an unyielding target to meet the requirements of the Transport Regulations is a 4 cm thick steel plate floated onto a concrete block during drying, that is mounted on firm soil or bedrock. The combined mass of the steel and concrete should be at least 10 times that of the specimen for the tests in paras 705, 722, 725(a), 727 and 735, and 100 times that of the specimen for the test in para. 737, unless a different value can be justified. The steel plate should have protruding fixed steel structures on its lower surface to ensure tight contact with the concrete. The hardness of the steel should be considered when testing packages with hard surfaces. To minimize flexure, the concrete should be sufficiently thick, but still allowing for the size of the test sample. Other targets that have been used are described in Refs [10–14]. Since flexure of the target is to be avoided, especially in the vertical direction, it is recommended that the target should be close to cubic in form, with the depth of the target comparable to the width and length.

Test for packagings designed to contain uranium hexafluoride

718.1. For the hydraulic test, only the cylinder is tested; valves and other service equipment should not be included in this leakage test. The valves and other service equipment should be tested in accordance with ISO 7195 [12].

Tests for demonstrating ability to withstand normal conditions of transport

719.1. The climatic conditions to which a package may be subjected in the normal transport environment include changes in humidity, ambient temperature and pressure, and exposure to solar heating and rain.

719.2. Low relative humidity, particularly if associated with high temperature, causes the structural materials of the packaging, such as timber, to dry out, shrink, split and become brittle; direct exposure of a package to the sun can result in a surface temperature considerably above ambient temperature for a few hours around midday. Extreme cold hardens or embrittles certain materials, especially those used for joining or cushioning. Temperature and pressure changes can cause ‘breathing’ and a gradual increase of humidity inside the outer parts of the packaging, and if the temperature falls low enough, it can lead to condensation of water inside the packaging. The humidity in a ship’s hold is often high and a fall in temperature will lead to considerable condensation on the outer surfaces of the package. If condensation occurs, fibreboard outer cases and spacers provided to reduce external dose rates might collapse. Exposure to rain may occur while a package is awaiting loading or while it is being moved and loaded on to a conveyance.

719.3. A package may also be subjected to both dynamic and static mechanical effects during normal transport. The former may comprise limited shock, repeated bumping and/or vibration; the latter may comprise compression and tension.

719.4. A package may suffer limited shock from a free drop on to a surface during handling. Rough handling, particularly rolling of cylindrical packages and tumbling of rectangular packages, is another common source of limited shock. It may also occur as a result of penetration by an object of relatively small cross-sectional area or by a blow from a corner or edge of another package.

719.5. Land transport often causes repeated bumping; all forms of transport produce vibrational forces that can cause metal fatigue and/or cause nuts and bolts to loosen. Stacking of packages for transport and any load movement resulting from a rapid change in speed during transport can subject packages to considerable compression. Lifting and a decrease in ambient pressure due to changes in altitude expose packages to tension.

719.6. The tests that have been selected to reproduce the kind of damage that could result from exposure to these climatic and handling/transport conditions and stresses are: the water spray test, the free drop

test, the stacking test and the penetration test. It is unlikely that any one package would encounter all of the rough handling or minor mishaps represented by the four test requirements. The unintentional release of part of the contents, though very undesirable, should not be a major mishap because of the limitation on the contents of a Type A package. It is sufficient for one each of three specimens to be subjected separately to the free drop, stacking and penetration tests, preceded in each case by the water spray test. However, this does preclude one specimen from being used for all the tests.

719.7. The tests do not include all scenarios of the transport environment to which a Type A package may be subjected. They are, however, deemed adequate when considered in relation with the other general design requirements related to the transport environment, such as ambient temperature and its variation, handling and vibration.

720.1. If the water spray is applied from four directions simultaneously, a 2 h interval between the water spray test and the succeeding tests should be observed. This interval accounts for the time that it takes for the water to seep gradually from the exterior into the interior of the package and lower its structural strength. If the package is then submitted to the free drop, stacking and penetration tests shortly after this interval, it will suffer the maximum damage. However, if the water spray is applied from each of the four directions consecutively, soaking of water into the interior of the package from each direction and drying of water from the exterior of the package will proceed progressively over a period of 2 h. Accordingly, no interval between the conclusion of the water spray test and the succeeding free drop test should be allowed.

721.1. The water spray test is primarily intended for packagings that rely on materials that absorb water or are softened by water or materials bonded by water soluble glue. Packagings whose outer layers consist entirely of metal, wood, ceramic or plastic, or any combination of these materials, may be shown to pass the test by reasoned argument, providing that they do not retain the water and significantly increase their mass.

721.2. One method of performing the water spray test that is considered to satisfy the conditions prescribed in para. 721 is as follows:

- (a) The specimen is placed on a flat horizontal surface in the orientation most likely to cause maximum damage to the package. A uniformly distributed spray is directed at the surface of the package for a period of 15 min from each of four directions at right angles; changes in spray direction should be made as rapidly as possible. More than one orientation may need to be tested.
- (b) The following additional test conditions are recommended for consideration:
 - (i) A spray cone apex angle sufficient to envelop the entire specimen;
 - (ii) A distance from the nozzle to the nearest point on the specimen of at least 3 m;
 - (iii) A water consumption equivalent to the specified rainfall rate of 5 cm/h, as averaged over the area of the spray cone at the point of impingement on the specimen and normal to the centre line of the spray cone;
 - (iv) Water draining away as quickly as delivered.
- (c) The requirement of para. 721 is intended to provide maximum surface wetting, and this may be accomplished by directing the spray downwards at an angle of 45° from the horizontal, as follows:
 - (i) For rectangular specimens, the spray may be directed at each of the four corners;

- (ii) For cylindrical specimens standing on one plane face, the spray may be applied from each of four directions at intervals of 90°.

721.3. The package should rest directly on the surface, to take account of water that can be trapped at the base of the package.

722.1. The free drop test simulates the type of shock that a package would experience if it were to fall off the platform of a vehicle or if it were dropped during handling. In most cases, packages would continue the journey after such shocks. Since heavier packages are less likely to be exposed to large drop heights during normal handling, the free drop distance for this test depends on the mass of the package. If a heavy package experiences a significant drop, it should be examined closely for damage or loss of contents or shielding. Light packages made from materials such as fibreboard or wood require additional drops to simulate repeated impacts due to handling.

722.2. Any drop test should be conducted with the contents of the package simulated to its maximum weight. More than one drop may be necessary to evaluate all possible drop attitudes. It may also be necessary to test specific features of the package, such as hinges or locks, to ensure that containment, shielding and nuclear criticality safety are maintained.

722.3. The features to be tested depend on the type of package to be tested. Such features include structural components, materials and devices designed to prevent loss or dispersal of radioactive substances or loss of shielding material (e.g. the entire containment system, such as lids, valves and their seals). For packages containing fissile material, the features could include, in addition to those mentioned above, components for maintaining subcriticality, such as a fuel holding frame and neutron absorbers.

722.4. The 'maximum damage' is the maximum impairment of the integrity of the package. To produce the maximum damage for most packages, the specimen should be dropped in one or more attitudes in such a way that the impact acceleration and/or deformation of the components under consideration is maximized. Most containers have some asymmetry, which gives different resistance to impact. In any investigation, sufficient structural elements should be considered to allow for the absorption of all the kinetic energy of the package. Arguments should be developed as to the damage in the various elements between the impact point and the concentration of mass with regard to their performance in absorbing the energy, in developing internal loads, in distorting, collapsing or folding, and in the consequences of these behaviours.

722.5. Packages of low mass might be held by hand above the target and dropped, providing that the desired attitude can be maintained. In all other cases, mechanical means should be devised to hold and release the package in the desired impact attitude. This could be simply a release mechanism suspended from an overhead structure, such as a roof member or a crane, or a tower specially designed for drop tests. The design of dedicated drop facilities has four main elements: the support, the release, the track guide (usually not used in direct drops), and the target, which is defined in para. 717. Sufficient height is required in the support to allow for the release mechanism, the support cable or harness and the full depth of the test item and still make it possible to attain the correct attitude and dropping height between the bottom of the package and the target. In the case where a package has impact limiters, the lowest point of the impact limiter would be used to determine the drop height. The release mechanism for a free drop test should allow for easy setting and instantaneous release, but should not produce undesirable effects on the attitude of the specimen and should not add to the mechanical damage to the specimen. Various types of mechanism, such as mechanical or electromagnetic, or combinations of mechanisms could be used. A number of test facilities are described in Refs [13, 14].

722.6. It is not necessary to consider all possible drop test orientations when conducting the drop test for normal conditions of transport. If it is not possible under normal conditions for the package to be dropped in certain orientations, these orientations could be ignored in assessing the maximum damage. It is envisaged that this relaxation should only be allowed for packages with large dimensions and/or large aspect ratios, and would require documented justification by the package designer.

722.7. Scale model techniques may be useful in determining the most damaging drop attitude (see paras 701.7–701.25). Since sensor frequencies and mounts may produce errors in the data obtained, care should be taken in the selection and use of instrumentation.

723.1. The stacking test is designed to simulate the effect of loads pressing on a package over a prolonged period of time to ensure that the effectiveness of the shielding and containment systems will not be impaired and, in the case of the contents being fissile material, will not adversely affect the configuration. This test duration corresponds to the requirements of the United Nations Recommendations [15].

723.2. Any package whose normal top surface (i.e. the side opposite the one that it normally rests on) is parallel and flat could be stacked. In addition, stacking could be achieved by adding feet, extension pads or frames to the package with convex surfaces. Packages with convex surfaces cannot be stacked unless extension pads or feet are provided.

723.3. The specimen should be placed with the base down on an essentially flat surface such as a flat concrete floor or steel plate. If necessary, a flat plate, which has sufficient area to cover the upper surface of the specimen, should be placed on the upper surface of the specimen so that the load may be applied uniformly to it. The weight of the plate should be included in the total stacking weight being applied. If a number of packages of the same kind are stackable, a simple method is to build a stack of five packages on top of the test specimen. Alternatively, a steel plate or plates or other convenient materials with a weight five times that of the package may be placed on the package.

724.1. The penetration test is intended to ensure that the contents will not escape from the containment system or that the shielding or confinement system would not be damaged if a slender object such as a length of metal tubing or the handlebar of a bicycle were to strike and penetrate the outer layers of the packaging.

Additional tests for Type A packages designed for liquids and gases

725.1. These additional tests for a Type A package designed to contain liquids or gases are imposed because liquid or gaseous radioactive material has a greater possibility of leakage than solid material. These tests do not require the water spray test first.

Tests for demonstrating ability to withstand accident conditions of transport

726.1. The accident tests specified in the Transport Regulations were originally developed to satisfy two purposes. First, they were conceived as producing damage to the package equivalent to that which would be produced by a very severe accident (but not necessarily all conceivable accidents). Second, the tests were stated in terms that provided the engineering basis for the design. Since analysis is an acceptable method of qualifying designs, the tests were prescribed in engineering terms that could serve as unambiguous, quantifiable input to these calculations. Thus, in the development of the test requirements, attention was given to how well these tests could be replicated (see, for example, para. 717.1).

726.2. The 1961 Edition of the Transport Regulations was based on the principle of protecting the package contents from the consequences of a 'maximum credible accident'. This phrase was later dropped because it did not provide a unique standard to work to, which is necessary to ensure the international acceptability of unilaterally approved designs. Recognition of the statistical nature of accidents and their consequences is now implicit in the requirements. A major aim of the package tests is international acceptability, uniformity and repeatability; tests are designed so that the conditions can be readily reproduced in any country. The test conditions are intended to simulate severe accidents in terms of the damaging effects on the package. They will produce damage exceeding that arising in the vast majority of recorded incidents, irrespective of whether or not the packages involved in these incidents contained radioactive material.

726.3. The purpose of the mechanical tests (para. 727) and the thermal test (para. 728) that follow is to produce damage equivalent to that which would be observed if the package were to be involved in a severe accident. The order and type of tests are considered to correspond to a real transport accident (i.e. mechanical impacts followed by thermal exposure). The test sequence also ensures mechanical damage to the package prior to the imposition of the thermal test; thus, the package is most liable to sustain maximum thermal damage. The mechanical and thermal tests are applied to the same specimen sequentially. The immersion test (para. 729) may be conducted on a separate specimen because the probability of immersion occurring in conjunction with the prescribed mechanical and thermal conditions as a result of an accident is extremely low.

727.1. Since Type B(U) and Type B(M) packages are transported by all modes of transport, the Type B(U) and Type B(M) test requirements are intended to take into account a large range of accidents that could expose packages to severe dynamic forces. The mechanical effects of accidents can be grouped into three categories: impact, crush and puncture loads. Although the test requirements were not originally derived directly from accident analyses, subsequent risk and accident analyses have demonstrated that these requirements represent very severe transport accidents [16–21].

727.2. In drop I, the combination of the 9 m drop height, unyielding target and most damaging attitude produce a condition in which most of the drop energy is absorbed by the structure of the packaging. In actual transport accidents, targets such as soil or vehicles will yield, absorbing part of the impact energy, and only higher velocity impacts may cause equivalent damage [19–21].

727.3. Thin walled packaging designs or designs with sandwich walls could be sensitive to puncture loads with respect to loss of containment integrity, loss of thermal insulation or damage to the confinement system. Even thick walled designs might have weak points, such as closures of drain holes and valves. Puncture loads could be expected in accidents as impact surfaces are frequently not flat. To provide safety against these loads, the 1 m drop test on to a rigid bar was introduced. The drop height and punch geometry parameters are based on engineering judgement rather than accident analyses.

727.4. Owing to their physical characteristics, most packages will be subject to the 9 m drop (impact) test rather than the crush test (drop III). The degree of severity provided by the 9 m drop test is smaller for light, low density packages than for heavy, high density packages, owing to the reduced impact energy and to the increased probability of impacting a relatively unyielding 'target' [19–25]. Such packages may also be sensitive to crush loads. Accident analyses show that the probability of dynamic crush loads in land transport accidents is higher than that of impact loads because lightweight packages are transported in larger numbers or together with other packages [16–18]. Also, handling and stowage mishaps can lead to undue static or dynamic crush loads. Consequently, the crush test (drop III) was introduced in the 1985 Edition of the Transport Regulations. Packages containing large quantities of alpha emitters are, owing to their limited shielding, generally light, low density packages. This includes,

for example, plutonium oxide powders and plutonium nitrate solutions, which are radioactive material with high potential hazards.

727.5. The attitudes of the package for the impact test (drop I) or crush test (drop III), and the penetration test (drop II) are required to be such as to produce the maximum damage, taking into account the thermal test. In addition, the order in which the tests are carried out is that which will be most damaging. The assessment of maximum damage should be made with concern for the containment of the radioactive material within the package, the retention of sufficient shielding to keep dose rates within the required limit and, in the case of fissile material, the maintenance of subcriticality. Any damage that would give rise to increased dose rates or loss of containment, or affect the confinement system after the thermal test, should be considered. Damage that might render the package inappropriate for reuse but does not affect its ability to meet these safety requirements should not be a reason for classifying the specimen as having failed.

727.6. Different modes of damage are possible as a result of the mechanical tests. It is necessary to consider the results of these modes in any analytical assessment to demonstrate compliance with the applicable requirements. The fracture of a critical component or the breach of the containment system might allow the escape of the radioactive material. Deformation might impair the function of radiation or thermal shields and/or might alter the configuration of fissile material and this should be reflected in the assumptions and predictions in the criticality assessment. Local damage to shielding might, as a result of the subsequent thermal test, give rise to deterioration of both the thermal and radiation protection. Consequently, investigations should include stress, strain, instability and local effect for all attitudes of drop where symmetry does not prevail.

727.7. Multiple drops of a specimen for the same test may not be feasible because of previous damage. It may be necessary to use more than one test sample or use analysis and reasoned argument based on engineering data to predict the most damaging attitude and to eliminate testing those attitudes where the safety is not impaired.

727.8. The most severe attitudes for symmetrical packagings that have either a cylindrical or cubic form may often be determined by the use of published information [24, 26]. Asymmetries, especially where protrusions occur, are often sensitive when used as the impact point. Lifting and handling devices such as skids or attachment points will often have a different strength or stiffness relative to the adjacent parts of the package and should be considered as possible impact points.

727.9. Discontinuities such as the lid or other penetration attachments could give a locally rigid structural element of limited strength, which could fail by either adjacent structural deformation or high loading (owing to deceleration) on their retained masses.

727.10. Thin wall packages, such as drums, should be considered in terms of the possibility of plastic deformation either causing loss of the containment seal or distorting the lid attachment sufficiently to allow the loss of the lid.

727.11. Paragraph 673 requires that, for fissile material, criticality analyses be made with the damage resulting from the mechanical and thermal test included. Aspects such as efficiency of moderator, loss of neutron absorbers, rearrangement of package contents, geometric changes and temperature effects should be considered in such analyses. The assumptions made in the criticality analysis should be in conformity with the effects of the mechanical and thermal tests, and all package orientations should be considered for the analysis.

727.12. It is intended that the drop of the package (drops I and II) or of the 500 kg mass (drop III) should be a free fall under gravity. If, however, some form of guiding is used, it is important that the impact

velocity should be at least equal to the impact velocity of the package or the mass under free fall (approximately 13.3 m/s for drops I and III).

727.13. For drop II, the required minimum length of the penetrating bar is 20 cm. A longer bar length should be used when the distance between the outer surface of a package and any inner component important for the safety of the package is greater than 20 cm or when the orientation of the model requires it. This is particularly true for specimens with large impact limiting devices, where the penetration can be considerable. The material specified for the construction of the bar is mild steel. The minimum yield stress of such material should not be less than 150 MPa nor more than 280 MPa. The yield to ultimate stress ratio should not be greater than 0.6. It may be difficult to perform a test where buckling of the bar is possible. In this case, justification of the bar length to obtain maximum damage to the specimen should be carried out.

727.14. For drop II, the most damaging package orientation is not necessarily a flat impact on to the bar top surface. For some package designs, it has been shown that oblique orientations at angles in the range 20–30° cause maximum damage because of the initiation of penetration of the bar corner into the external envelope of the package.

727.15. For preliminary design purposes only, for the outer shell of a steel–lead–steel packaging, the following equation may be used to estimate the shell thickness required to resist failure when the package is subjected to the penetration test:

$$t=2148.5\left(\frac{w}{s}\right)^{0.7} \quad (5)$$

where

t is the outer shell thickness (cm);

w is the mass of the package (kg);

s is the tensile strength of the outer shell material (Pa).

This equation is based on tests employing annealed mild steel backed by lead [26]. Packages using materials having different physical properties could require different thicknesses of the outer steel shell to meet the requirements. For packages with small diameters (less than 0.75 m), or using materials having different physical properties, or for impacts near changes of geometry or at oblique attitudes, the preliminary estimate may not be conservative [26].

727.16. For drop II, the bar is required to be mounted on a target as described in para. 717. The damage due to a drop on to a flat surface is expected to be assessed with drop I. Therefore, it is not necessary that the secondary drop (drop II) induces additional damage. The surface that surrounds the bar does not need to meet the requirements set forth in para. 717. However, the surface that surrounds the bar should not reduce the energy absorbed from the impact of the package on the bar.

727.17. For the crush test (drop III), the packaging should rest on the target in such a way that it is stable in the orientation selected to induce maximum damage. To achieve this, it may be necessary to provide support, in which case the presence of the support should not influence the damage to the package [27]. When determining the most damaging impact position the designer should consider that the impact of the plate could be anywhere on the surface of the specimen. The orientation of the specimen should be

selected to ensure that most of the impact energy goes into crushing the specimen. It is not intended that the corner of the impact plate should be the first point of impact with the test specimen.

727.18. Measuring instrumentation on test specimens and even on the target (i.e. to measure the response to impact) should be used for the following reasons:

- (a) Validation of assumptions in the safety analysis;
- (b) As a basis for design alterations;
- (c) As a basis for the design of comparable packages;
- (d) As a benchmark test for computer codes.

727.19. Functions that should be measured during the 9 m drop test (drop I) or crush test (drop III) include the deceleration–time function and the strain–time function. Where electronic devices are used to acquire, record and store data, examination of any filtering, truncating or cropping should be made so that no data peaks of significance are lost. Most instruments will require cable connections to external devices. These connections should be such that they neither restrict the free fall of the package nor restrain the package in any way after impact (see para. 701.9).

727.20. Reference [28] may provide useful information when selecting the initial angle between the package axis and the target that results in the maximum damage by secondary impact during a 9 m drop test (drop I).

728.1. References [16–18, 29–31] indicate that the thermal test specified in para. 728 provides an envelope of environmental conditions that encompasses most transport related accidents involving fires. The Transport Regulations specify a test condition based on a liquid hydrocarbon–air fire with a duration of 30 min. Other parameters relating to fire geometry and heat transfer characteristics are specified in order to define the heat input to the package.

728.2. The thermal test specifies a liquid hydrocarbon pool fire, which is intended to encompass the damaging effects of fires involving liquid, solid or gaseous combustible materials. Actual fires involving liquids such as liquid petroleum gas (LPG) or liquid natural gas (LNG) and liquid hydrogen are covered by the test because pool fires with such fuels generally will not last for 30 minutes. Liquid petroleum products are frequently transported by road, rail and sea and would be expected to give rise to a fire following an accident. Liquids that can flow around the package and create the stipulated conditions are restricted to a narrow range of calorific values, so the severity of the fire is quite well defined.

728.3. The flame temperature and emissivity (800°C and 0.9, respectively) represent averaged conditions (in time and space) found in pool fires. Locally within fires, temperatures and heat fluxes can exceed these values. However, non-ideal positioning of a package within a fire, movement with time of the fire source relative to the package, shielding by other non-combustible packages or conveyances involved in the accident, wind effects and the massive structure of many Type B(U) and Type B(M) packages will all combine to average the conditions such that they conform to, or are less severe than, the test description [31, 32]. The presence of a package and the remoteness from the oxygen supply (air passing through about 1 m of flame) may both tend to depress the flame temperature adjacent to the package. Natural winds can supply extra oxygen but tend to remove flame cover from parts of the package, hence the requirement for quiescent ambient conditions. Use of a vertical flame guide underneath the package will minimize the effect of wind and improve flame coverage [33]. The flame emissivity is difficult to assess, as direct measurements are not generally available, but indications from

practical tests suggest that the 0.9 value specified is an overestimate. The combination of parameters in the test results in severe flame conditions that are unlikely to be exceeded in accident conditions.

728.4. The duration of a large petroleum fire depends on the quantity of fuel involved and the availability of firefighting resources. Liquid fuel is carried in large quantities, but, in order to form a pool, any leakage has to flow into a well defined area around the package with consequent loss by drainage. In general, not all the contents of a single tank will be involved in this way — much of the contents will be consumed either in the tank itself or during transfer to the vicinity of the package. The contents of other tanks will most likely be burnt at a more remote location as the fire moves from tank to tank. Recognition should also be given to the fact that, when lives are not directly at risk, fires are often allowed to continue to natural extinction. Consequently, historical records of fire durations should be viewed critically. The 30 min duration is therefore chosen from consideration of these factors and encompasses the low probability of a package being involved in a fire with a large volume of fuel and the ‘worst case’ geometry specified. The low probability, long duration fire is most likely to occur in combination with a geometry that effectively reduces the thermal input, with the package resting on the ground and/or protected by the vehicle structure. The heat input from the thermal test is thus consistent with realistic, severe accident situations.

728.5. The following configuration for the fire geometry minimizes the effects of radiation losses and maximizes heat input to the packages:

- (a) A 0.6–1 m elevation of the package ensures that the flames are well developed at the package location, with adequate space for the lateral in-flow of air. This improves flame uniformity without affecting the heat fluxes.
- (b) The extension of the fuel source beyond the package boundary ensures a minimum flame thickness of about 1 m, providing a reasonably high flame emissivity. To improve flame coverage, the size of the pool should extend between 1 and 3 m beyond any external surface of the test specimen. Larger extensions can lead to oxygen starvation at the centre and relatively low temperatures close to the package [34].

728.6. Only natural convection and thermal radiation should be allowed to contribute to heat loss from the package surface after the end of the fire.

728.7. The Transport Regulations allow other values of surface absorptivity to be used as an alternative to the standard value of 0.8, if they can be justified. In practice, a pool fire is so smoky that it is probable that soot will be deposited on cool surfaces and thereby modify the conditions. This is likely to increase the absorptivity but interpose a conduction barrier. The value of 0.8 is consistent with the thermal absorptivity of paint and can be considered as approximating the effects of surface soot. As a surface is heated, the soot may not be retained, and lower values of surface absorptivity could result.

728.8. A significant proportion of the heat input may derive from convection, particularly when the outer surface is finned and early in the test when the surfaces are relatively cool. The convective heat input should be at least equivalent to that for a hydrocarbon fuel–air fire at the specified conditions.

728.9. The effects of the thermal test are, of course, dominated by increased package temperatures and the consequent effects, such as high internal pressures. The peak temperature depends to some extent on the initial temperature, which should therefore be determined using the highest appropriate initial conditions of internal heat generation, solar heating and ambient temperature. For a practical test, not all of these initial conditions will be achievable, so appropriate measurements (e.g. ambient temperature) should be made, and package temperatures corrected after the test.

728.10. The fire conditions defined in the Transport Regulations and the requirement for full engulfment for the duration of the test represent a very severe test of a package. It is not intended to define the worst conceivable fire. In practice, some parameters may be more severe than specified in the Transport Regulations but others would be less severe. For example, it is difficult to conceive of a practical situation where all the surfaces of a package could experience the full effects of the fire, since it would be expected that a significant fraction of the surface area would be protected, either by the ground or by wreckage and debris arising from the accident. Emphasis has been placed on the thermal heat flux rather than on the individual parameters chosen, and in this respect the conditions specified represent a very severe test for any package [32]. It should also be emphasized that the thermal test is only one of a cumulative series of tests, which is required to be applied to cause maximum damage to a package. This damage is required to remain small in terms of the stringent criteria governing containment integrity, dose rate and criticality safety.

728.11. The requirements of the thermal test may be met by a practical test, by a calculated assessment, or by a combination of both. The last approach may be necessary if, for example, the initial conditions required for a practical test were not achieved or if all the package design features were not fully represented in the experiment. In many cases, the consequences of the thermal test need to be determined by calculation, which therefore becomes an integral part of the planning and execution of the practical test. Other methods or techniques may be used but more justification might be expected in support of such an approach. The Transport Regulations specify certain fire parameters that are essential input data for the calculation method but are generally uncontrollable parameters in practical tests. Standardization of the practical test is therefore achieved by defining the fuel and test geometry for a pool fire and requiring other practical methods to provide the same, or greater, heat input.

728.12. With regard to the package design, some shielding materials contain eutectic constituents with melting temperatures that are lower than the 800°C stipulated in the thermal test. Therefore, consideration should be given to the capability of any structural materials to retain them. Local shielding materials, such as plastics, paraffin wax or water, may vaporize, causing a pressure that might rupture an outer shell that might have been weakened by damage from the mechanical tests. A thermal analysis may be required to determine whether such pressures can be attained.

728.13. The bottom of the package to be tested should be between 0.6 and 1 m above the surface of the liquid fuel source. Unless the fuel is replenished, or replaced by another liquid, such as water, the level will fall during the test, probably by about 100–200 mm. The specimen package should be supported in such a way that the flow of heat and flames is perturbed by the minimum practical amount. For example, a larger number of small pillars is to be preferred to a single support covering a large area of the package. The transport vehicle, and any other ancillary equipment that might protect the package in practice, should be omitted from this test as the protection was taken into account in the test definition.

728.14. The pool size should extend between 1 and 3 m beyond the edges of the package, so that all sides of the package are exposed to a luminous flame not less than 0.7 m high and not more than 3 m thick, taking into account the reduction of the flame thickness with increasing height over the pool. In general, larger packages will require a larger extension as flame thicknesses will vary more over the greater distances involved. The requirement for fully engulfing flames can be interpreted as a need for all parts of the package to remain invisible throughout the 30 min test, or at least for a large proportion of the time. This is best achieved by designing for thick flame cover that can accommodate natural variations in thickness without becoming transparent. A low wind velocity (quiescent conditions) is also required for stable flame cover, although large fires might generate high local wind velocities. Wind screens or baffles can help to stabilize the flames, but care should be taken to avoid changing the character of the flames and to avoid reflected or direct thermal radiation from external surfaces. This

would enhance the heat input and although this would not invalidate the test, it could make it more stringent than necessary.

728.15. Wind speeds of less than about 2 m/s should not invalidate the test and short duration gusts of higher speeds will not have a large effect on high heat capacity packages, particularly if flame cover is maintained. Open air testing should only take place when rain, hail or snow will not occur before the end of the post-fire cooldown period. The package should be mounted with the shortest dimension vertical for the most uniform flame cover, unless a different orientation will lead to a higher heat input or greater damage, in which case such an arrangement should be chosen. It is acceptable to consider a single orientation of the package for both the 30 min fire test and the subsequent cooling period. The orientation of the package for the 30 min fire test and the subsequent cooling period should be that which produces the maximum damage to the package. However, the orientation of the package to be considered for the assessment of the steady state prior to the fire test is that of the routine conditions of transport.

728.16. The fuel for a pool fire should comprise a distillate of petroleum with a distillation endpoint of 330°C maximum and an open cup flash point of 46°C minimum, and with a gross heating value of between 46 and 49 MJ/kg. This covers most hydrocarbons derived from petroleum and having densities of less than 820 kg/m³, for example, kerosene and JP4 type fuels. A small amount of more volatile fuel may be used to ignite the pool as this will have an insignificant effect on the total heat input.

728.17. The choice of instrumentation will be dictated by the use to be made of a practical thermal test. Where a test provides data to be used in calculations to demonstrate compliance, some instrumentation is essential. The type and positioning of the instruments will depend on the data needed, for example, internal pressure and temperature measurements may be necessary and, where stress is considered important, strain gauges should be installed. In all cases, the cables carrying signals through the flames should be protected to avoid extraneous voltages created at high temperatures. As an alternative to continuous measurement, the package might be equipped in such a way that instruments could be connected soon after the fire and early enough to measure the peak pressure and temperature. A measurement of leakage can be achieved by pre-pressurization and re-measurement after the thermal test, making appropriate adjustments for temperature where necessary (see paras 659.5–659.24).

728.18. The duration of the test can be controlled by providing a measured supply of fuel calculated to ensure the required 30 min duration, by removing the supply of fuel a predetermined time before the end of the test, by discharging the fuel from the pool at the end of the test or by carefully extinguishing the fire without affecting the package surfaces with the extinguishing agent. The duration of the test is the time between the achievement of good flame cover and required flame temperatures, and the time at which such cover and temperature are lost.

728.19. Measurements should continue after the fire, at least until the internal temperatures and pressures are falling. If rain or other precipitation occurs during this period, a temporary cover should be erected to protect the package and prevent inadvertent extinguishing of the combustion of the package materials, with care taken not to restrict heat loss from the package.

728.20. Where the test supplies data for an analytical evaluation of the package, measurements made during the test should be corrected for non-standard initial conditions including ambient temperature, insolation, internal heat load and pressure. The effects of partial loading (i.e. less than full contents) on the package heat capacity and heat transfer should be assessed.

728.21. A furnace test is often more convenient than an open pool fire test. Other possible test environments include pit fires and an open-air burner system operating with liquefied petroleum gas [35]. Any such test is acceptable provided that it meets the requirements of para. 728. The oxygen level

should be taken into account, especially when the package contains combustible material [36]. Methods to verify the required heat input and methods to prove the thermal environment can be found in Refs [37–39].

728.22. Requiring that the internal temperature increase be not less than that predicted for an 800°C fire ensures that the heat input is satisfactory. However, the test should continue for at least 30 min, during which the time averaged environment temperature should be at least 800°C. A high emissivity radiation source should be created by selecting a furnace either with an internal surface area very much larger than the envelope area of the package or with an inherently high emissivity internal surface (0.9 or higher). Many furnaces are unable to reproduce either the desired emissivity or the convective heat input of a pool fire, so an extension of the test duration might be necessary to compensate. Alternatively, a higher furnace temperature could be used but in this case the test duration should be a minimum of 30 min. The furnace wall temperature should be measured at several places, sufficient to show that the average temperature is at least 800°C. The furnace can be preheated for a sufficient time to achieve thermal equilibrium, so avoiding a large temperature drop when the package is inserted. The 30 min minimum duration should be such that the time averaged environment temperature is at least 800°C.

728.23. The calculation of heat transfer or the determination of physical and chemical changes of a full size package based on the extrapolation of the results from a thermal test of a scale model may be impossible without many different tests. A wide ranging programme simulating each process separately would require an extensive investigation using a theoretical model, consequently the technique has little inherent advantage over the normal analytical approach. Any scale testing, and interpretation of the results, should be shown to be technically valid. However, the use of full scale models of parts of the package might be useful if calculation for a component (such as a finned surface) proves difficult. For example, the efficiency of a heat shield, or of a shock absorber acting in this role, could be most readily demonstrated by a test of this component with a relatively simple body beneath it. Component modelling is of importance for the validation of computer models. However, measurements of flame temperature and flame and surface emissivity are difficult and might not provide a sufficiently accurate specification for a validation calculation. Component size should be selected and appropriate insulation provided so that heat entering from the artificial boundaries (i.e. those representing the rest of the package) is not significant.

728.24. Thermal testing of reduced scale models meeting the specified conditions of the thermal test may be performed and lead to conservative results for temperatures, assuming that there is no fundamental change in the thermal behaviour of the components.

728.25. The most common method of package assessment for the thermal test is calculation. Many general purpose, heat transfer computer codes are available for such package modelling, although care should be taken to ensure that the provisions available in the code are adequate for the package geometry, in particular for representing radiation heat transfer from the environment to external surfaces. Practical tests may ultimately be required for validation, but arguments showing that the approximations or assumptions produce a more stringent test than required are often used. In general, code validation is accomplished by comparison with analytical solutions and comparison with other codes.

728.26. Generally, the normal conditions of transport will have been assessed by calculation, so detailed temperature and pressure distributions should be available. Alternatively, the package temperatures might have been measured experimentally, so that, after correction to the appropriate ambient temperature and for the effects of insolation and the heat load due to the contents, these provide the initial conditions for the calculated thermal test conditions. Ambient temperature corrections can be made in accordance with para. 653.4.

728.27. The external boundary conditions of the fire should represent thermal radiation, reflection and convection. The temperature is specified by the Transport Regulations as an average of 800°C, and therefore, in general, a uniform average temperature of 800°C should be used for the thermal radiation source and for convective heat transfer.

728.28. The flame emissivity is prescribed as 0.9. This can be used without ambiguity for plane surfaces but, for finned surfaces, the thin flames between the fins will have an emissivity much lower than 0.9. The dominant source of radiation to the finned surfaces will therefore be the flames outside the fins; radiation from flames within the fin cavity can be ignored. In all cases, appropriate geometric view factors should be used for the fin envelope, and reflected thermal radiation should be taken into account. Care should be taken to avoid the inclusion of thermal radiation ‘reflected’ from a surface representing flames as this is a non-typical situation.

728.29. The surface absorptivity is prescribed as 0.8 unless an alternative value can be established. In practice, demonstration of alternative values will be extremely difficult as surface conditions change in a fire, particularly as a result of soot, and evidence obtained after a fire may not be relevant. The value of 0.8 is therefore most likely to be used in analytical assessments. It is important to take reflected thermal radiation into account, particularly with complex finned surfaces, as multiple reflections increase the effective absorptivity to near unity. This complexity can be avoided by assuming unity for the surface absorptivity, but, even in this case, surface to surface thermal radiation should not be ignored, particularly during the cooldown period.

728.30. Convection coefficients during the fire should be justified. Pool fire gas velocities are generally found to be in the range 5–10 m/s [40]. Use of such velocities in forced convection, heat transfer correlations (e.g. the Colburn relation $Nu = 0.036 Pr^{1/3} Re^{0.8}$ quoted in Ref. [41]) results in convective heat transfer coefficients of about $10 \text{ W}\cdot\text{m}^{-2}\cdot\text{°C}^{-1}$ for large packages. Natural convection coefficients (about $5 \text{ W}\cdot\text{m}^{-2}\cdot\text{°C}^{-1}$) are not appropriate as this implies downward gas flow adjacent to the cool package walls, whereas, in practice, a general buoyant upward flow will dominate. The upper surface of a package is unlikely to experience such high gas velocities in quiescent atmospheric conditions, as the region will include a stagnation area in the lee of the upward gas flow. The reduced convection in that area is adequately represented by the average coefficient as the averaging process includes this effect.

728.31. Convection coefficients for the post-test, cooldown period can be obtained from standard natural convection references, e.g. Ref. [41]. In this case, coefficients appropriate for each surface can readily be applied. For vertical planes, the turbulent natural convection equation for Grashof numbers $>10^9$ is given by:

$$Nu = 0.13 (Pr \cdot Gr)^{1/3} \quad (6)$$

The boundary conditions used for the assessment of conditions under normal operation should be used. Changes to surface conditions and/or geometry resulting from the fire should be recognized in the post-fire assessment as these might affect both thermal radiation and convection heat losses. Allowance should be made for continued heat input if package components continued to burn following the thermal test exposure.

728.32. Consideration should be given to the proper modelling of all thermal shields, such as impact limiters, which are affected after the mechanical tests stated in para. 727. Some examples are changes in shape and/or dimensions, changes in material densities due to compaction, and separation of the thermal shield.

728.33. Calculations that are performed using finite difference or finite element models should have a sufficiently 'fine mesh' or element distribution to enable proper representation of the internal conduction and external and internal boundary conditions. External features such as fins should be given special attention as temperature gradients can be severe, perhaps necessitating separate detailed calculations to determine the heat flux to the main body. Consideration should be given to the choice of one, two or three dimensional models and to the decision on whether the whole package or separate parts are to be evaluated.

728.34. External surfaces of low thermal conductivity can lead to oscillations in computed temperatures. Special techniques (e.g. simplified boundary conditions) or assumptions (e.g. that time averaged temperatures are sufficiently accurate) might be necessary to deal with this.

728.35. Generally, conduction and radiation can be modelled explicitly and external convection provides few problems for general purpose computer codes. However, experimental evidence may be required to support modelling assumptions and basic data used to represent internal convection and radiation. Radiation reflection will be important in gas filled packages, and insufficient knowledge of thermal emissivity may restrict the final accuracy. A sensitivity study using different values of thermal emissivity can be used to show that the assumptions are adequate or to provide conservative (i.e. maximum) limits on calculated temperatures.

728.36. Internal convection will be important for a water filled package and might be significant in a gas filled package. This process is difficult to predict unless there is experimental evidence to support modelling assumptions. Where water circulation routes are provided, internal heat dissipation will be rapid compared with other time constants, and simplifying assumptions may be made (e.g. water can be modelled by an artificial material with high conductivity). Care should be taken to consider areas not subject to circulation (stagnant regions), as high temperatures can occur there because of the inherently low thermal conductivity of water.

728.37. Gas gaps and contact resistances can vary with the differential expansion of components, and it is not always clear whether an assumption will yield high or low temperatures. For example, a high resistance gas gap will prevent heat flow, minimizing temperatures inside but maximizing other temperatures because of the reduced effective heat capacity. In such cases, calculations based on two extreme assumptions might provide evidence that both conditions are acceptable and, by implication, that all variations in between are also acceptable. The gaps and contact resistance in the test sample should be representative of future production. Seals are rarely represented explicitly, but local temperatures could be used as a close approximation to the temperature of the seals.

728.38. The calculation of a thermal test transient should include the initial conditions, a 30 min period with external conditions representing the fire and a cooldown period extending until all temperatures are decreasing with time. In addition, further calculation runs, perhaps with a different mesh distribution, should be performed to check the validity of the model and to assess the uncertainties associated with the modelling assumptions.

728.39. The results of the analysis will be used to confirm that the package has adequate strength and that leakage rates will be acceptable. The determination of pressures from calculated temperatures is thus an important step, particularly where the package contains a volatile material such as water or uranium hexafluoride. Often, items such as lead shields may not be allowed to melt as the resulting condition cannot be accurately defined and thus shielding assessments may not be possible. Component temperatures, if necessary in connection with local hot spots, should be examined to ensure that melting or other modes of failure will not occur in the whole procedure. The uncertainties in the model, the data (e.g. manufacturing tolerances) and the limitations of the computer codes should be recognized, and allowances should be made for these uncertainties.

728.40. The post-exposure equilibrium temperatures and pressure might be affected by irreversible changes in the thermal test (perhaps due to protective measures such as the use of expanding coatings or the melting and subsequent relocation of lead within the package). These effects should be assessed.

729.1. As a result of transport accidents near or on a river, lake or sea, a package could be subjected to an external pressure from immersion under water. To simulate the equivalent damage from this low probability event, the Transport Regulations require that a packaging can withstand external pressures resulting from immersion at reasonable depths. Engineering estimates indicated that water depths near most bridges, roadways or harbours would be less than 15 m. Consequently, 15 m was selected as the immersion depth for packages (it should be noted that packages containing large quantities of irradiated nuclear fuel should be able to withstand a greater depth (see para. 730)). While immersion at depths greater than 15 m is possible, this value was selected to encompass the equivalent damage from most transport accidents. In addition, the potential consequences of a significant release would be greatest near the coast or in a shallow body of water. The 8 h time period is sufficiently long enough to allow the package to achieve a steady state from the rate dependent effects of immersion (e.g. flooding of exterior compartments).

729.2. The water immersion test may be satisfied by immersion of the package, by a pressure test of at least 150 kPa, by a pressure test on critical components combined with calculations, or by calculations for the whole package. The entire package might not have to be subjected to a pressure test. Justification of model assumptions about the response of critical components should be included in the evaluation.

Enhanced water immersion test for Type B(U) and Type B(M) packages containing more than $10^5 A_2$ and Type C packages

730.1. See paras 660.1–660.7, 729.1 and 729.2.

730.2. The enhanced water immersion test may be satisfied either by the immersion of the package, by an external pressure test of at least 2 MPa, by a pressure test on critical components combined with calculations, or by calculations for the whole package. As an example, critical components such as the lid area may be subjected to an external gauge pressure of at least 2 MPa and the balance of the structure may be evaluated by calculation.

730.3. If calculational techniques are adopted, it should be noted that established methods are usually intended to define the materials, properties and geometries that will result in a design capable of withstanding the required pressure loading without any impairment. In the case of the requirement for immersion for a period of not less than 1 h, some degree of buckling or deformation of the package is acceptable, provided the final condition conforms with para. 660.

Water leakage test for packages containing fissile material

732.1. This test is required because the in-leakage of water might have a large effect on the allowable fissile material content of a package. The sequence of tests is selected to provide conditions that will allow the free in-leakage of water into the package, together with damage that could rearrange the fissile contents.

733.1. The immersion test is intended to ensure that the criticality assessment is conservative. The sequence of tests prior to the immersion simulates accident conditions that a package could encounter in a severe accident near or on water during transport.

Tests for Type C packages

734.1. The Transport Regulations do not require the same specimen to be subjected to all the prescribed tests because no real accident sequence combines all the tests at their maximum severity. Instead, the Transport Regulations require the tests to be performed in sequences that concentrate damage in a logical sequence typical of severe accidents (see Ref. [42]).

734.2. Different specimens may be subjected to the sequences of tests. Also, the evaluation criterion for the water immersion test prescribed in para. 730 is different from the criterion specified for the other tests. The evaluation of the package with regard to shielding and containment integrity is required to be performed after completing each test sequence.

735.1. The possible occurrence of puncture and tearing is significant. However, the accident conditions are qualitatively and quantitatively difficult to describe [43, 44]. Puncture damage could be caused by parts of the airframe and/or the cargo. Puncture on the ground is also possible, but is considered to be of less importance.

735.2. A consequence of puncture can be a release from the package containment system, but this would have a very low probability of occurrence. A larger concern is that of damage to the thermal insulation capability of a package, which would result in unsatisfactory behaviour if the impact is followed by a fire.

735.3. The design of the test requires the definition of: a probe with respect to length, diameter and mass; an unyielding target; and an impact speed. One possibility for specifying the probe was to refer to components of the aircraft. An I-beam has been incorporated in some tests or test proposals, but adoption of a more conventional geometric object was preferred, namely, a right circular cone. This shape is considered to be one that could cause considerable damage. The height of fall or travelling distance of a probing structure in the range of a few metres is representative of the collapse of structures or bouncing within the aircraft.

735.4. Failure in engines can generate unconfined engine fragments at a rate that deserves consideration. Loss of the aircraft is only one among many possible consequences of the emission of missiles, which can be quite energetic (up to 105 J). However, the probability of a fragment hitting a package has been found to be very low in specific studies [42, 45, 46] and probability of penetration, although not estimated, would be lower. Thus, on the basis of this low probability, it was considered unnecessary to define a test to cover engine fragment damage.

735.5. For para. 735(a), the total length of the penetrator probe and details of its construction beyond the frustum are left unspecified but should be adjusted to ensure that the required mass is attained. For para. 735(b), the penetrating object should be of sufficient length and mass to extend through the energy absorbing and thermal insulating materials surrounding the inner containment vessel, and should also be of sufficient rigidity to provide a penetrating force without itself being crushed or collapsed. In both cases, the centres of gravity of the probe and the packaging should be aligned to preclude non-penetrating deflection [47].

735.6. See also para. 727 for additional information.

736.1. The duration of the fire test for accidents during air transport was set at 60 min. Statistical data on fires resulting from such accidents support the conclusion that the 60 min thermal test exceeds most severe fire environments that a package would be likely to encounter in an aircraft accident. Fire duration statistics are frequently biased by the duration of burning of ground structures and other features not related to the aircraft wreckage, as well as by the location of consignments involved in the

accident. To take this effect into account, information on fire duration was evaluated carefully to avoid bias by accounts of fires that did not involve the aircraft

736.2. The importance of ‘fireballs’ resulting from a severe aircraft accident was evaluated in establishing the requirements for the fire test. Surveys have shown that fireballs of short duration and high temperature occur commonly in the early stages of aircraft fires and are generally followed by a ground fire [48, 49]. The heat input to the package arising from fireballs is not significant compared with the heat input from the extended fire test. Consequently, no tests are required to evaluate a fireball’s impact on package survival.

736.3. The presence of certain materials in an aircraft, for example, magnesium, could result in an intense fire. However, this is not considered to be a serious threat to the package because of the small quantities of such material that are likely to be present and the localized nature of such fires. Aluminium is present in large quantities in the form of fuselage panels. However, these panels will melt away within a few minutes. Consequently, it is not considered credible that aluminium would burn and increase the package heat load greatly.

736.4. This test is not sequential to the 90 m/s impact speed test described in para. 737. In severe accidents, high speed impact and long duration fires are not expected to be encountered simultaneously because high velocity accidents disperse fuel and lead to non-engulfing, wider area fires of lower consequence. The Type C package is required to be subjected to an extended test sequence consisting of the Type B(U) and Type B(M) impact test (drop I – para. 727(a)) and crush test (drop III - para. 727(a) and (c)), followed by the puncture–tearing test (para. 735) and then the enhanced thermal test (para. 736). It is considered that the additive combination of these tests provides protection against severe air accidents that could involve both impact and fire.

736.5. Account should be taken of melting, burning, or other loss of the thermal insulant or structural material upon which the insulant depends for its effectiveness in the longer duration of this fire compared with that for Type B(U) and Type B(M) packages.

736.6. For further information, see para. 728.1–728.40.

737.1. In determining the conditions for the impact test, the goal was to define the combination of specified velocities normal to an unyielding target that will produce damage conditions to the specimen equivalent to those that might be expected from aircraft impacts at actual speeds on to real surfaces and at randomly occurring angles. Probabilistic distributions of the variables in accidents were considered, as well as the package orientation that is most vulnerable to damage.

737.2. Data on which to base accident analyses have been obtained on the particulars of accidents that are filed by officials on the scene and those involved in subsequent investigations. Some of the data are based on actual measurements. Other data are derived by analysis of data and inferences based on a notion of how the accident probably progressed. Each accident report is evaluated to extract certain basic characteristics, such as impact speed, character of the impacted mass, impact angle, and the nature of the impact surface. It is frequently necessary to obtain other accounts of an accident to cross-check information.

737.3. Basic data from an accident report are useful, but do not include the effects of the accident on the cargo involved. For instance, the damage to the aircraft and the cargo could be very different if the aircraft impacted a small car, a soft bank, or a bridge abutment. To take this effect into account, an analysis is performed to translate the actual impact velocity into an effective head-on impact velocity onto an unyielding surface (see paras 717.1 and 717.2). Thus, all of the available energy is spent in the

deformation of the aircraft and the al packages. It is normal to assume that the aircraft absorbs no energy, as this assumption leads to conservative analyses.

737.4. The assumption that the cargo impacts at the speed of the aircraft on to an unyielding surface will result in an effective impact speed that is lower and which depends on the relative strength of the cargo compared with that of the actual impacting surface. For a ‘hard’ package and ‘soft’ target (e.g. a spent fuel flask on water), the ratio of actual to effective velocity might range from 7 to 9. For similar hardness in package and surface, the ratio might be 2 or more. For concrete roadways and runways, the velocity ratio could range from 1.1 to 1.4. There are very few surfaces for which the ratio would be unity [42].

737.5. Conversion of basic accident report data to effective impact velocity is performed to normalize the accident conditions to produce impact data in a standard format that removes much of the variability of the accident scenarios but which, at the same time, preserves the stress on the cargo. Repeating this process for all relevant aircraft accidents produces a statistical basis for choosing an effective impact speed on to a rigid target [47–49].

737.6. Package designs that release no more than an A_2 quantity of radioactive material in a week when subjected to performance testing might be assumed to release their total contents under slightly more severe conditions. However, such eventualities are not expected. Rather, it is expected that a package designed to meet the Transport Regulations will limit releases to accepted levels until the accident environments are well beyond those provided in the required tests, and then will only gradually produce an increased release as the accident conditions greatly exceed the test levels, i.e. packages should fail ‘gracefully’. This behaviour results from:

- (a) The safety margins that exist in package designs;
- (b) The capability of materials used in the package for a specific purpose, such as shielding, to mitigate loads when that capability is not explicitly considered in the design analysis;
- (c) The capability of materials to resist loads well beyond the elastic limit;
- (d) The reluctance of designers to use — and/or competent authorities to approve — materials that have abrupt failure thresholds as a result of melting or fracturing in environments likely to occur in transport.

737.7. While all the features of good package design are expected to provide the desired property of graceful failure, it is also true that there are only very limited data available on packages tested to failure to see how release increases with the severity of the accident. Limited test data and analyses that have been performed support the concept of graceful failure [49–51].

737.8. The impact velocity for the test was derived from frequency distribution cumulative probability studies [42, 52–54]. Most accident analyses reveal that, as the severity of the impact increases, the number of events with that severity increases rapidly to a peak and then falls to zero as the severity approaches a physical limit, such as the top speed of the aircraft. Plotting these data as a cumulative curve (i.e. a percentage of events with severity less than a given value) gives a curve that rises quickly at first and then rises very slowly after the ‘knee’ of the curve is reached. When the data are plotted in a format that shows the probability of exceeding a given impact velocity, the scarcity of severe accidents manifests itself as a distinct bend or knee in the curve. This area of the curve is of interest because it indicates where increased levels of protection built into a package begin to have less effect on the probability of failure. Furthermore, the area to the left of the knee covers approximately 95% of all accidents. The knee of the curve occurs at about 90 m/s: this value was chosen for the impact test.

737.9. Requiring a package design to protect against a normal velocity much higher than the value at the knee generally means a more massive, more complicated and more expensive package design that achieves little increase in the protection of the public. In addition, a design that survives impact at the velocity at the knee will survive many accidents at speeds above the knee because of the conservatism in package design, conservatism in the analysis of accident data and the conversion of those data into effective impact speed on to an unyielding target. In other words, complete catastrophic failure of containment is not likely to occur, even at the extreme portion of the curve.

737.10. The need for a package terminal velocity test was discussed in the context of the impact test, but it is expected that the impact of a package at terminal velocity is taken into account by the 90 m/s impact test. The purpose of a terminal velocity condition would be to demonstrate that the package design would provide protection in the event that the package is ejected from the aircraft. This situation could arise as a result of mid-air collision or in-flight airframe failure. Nevertheless, it is noted that Type C package requirements already include an impact test on an unyielding surface at a velocity of 90 m/s. This test provides a rigorous demonstration of package integrity for cargo overboard scenarios.

737.11. While the free fall package velocity may exceed 90 m/s, it is unlikely that the impact surface would be as hard as the unyielding surface specified in the impact test. It is also noted that the probability of aircraft accidents of any type is low and that the percentage of such accidents that involve mid-air collisions or in-flight airframe failures is very low. If such an accident were to occur to an aircraft carrying a Type C package, damage to the package could be mitigated if the package remained attached to airframe wreckage during descent, which would tend to reduce the package impact velocity.

737.12. Subjecting a package to an impact on an unyielding surface with an impact speed of 90 m/s is a difficult test to perform well. This impact speed corresponds to a free drop through a height of about 420 m, without taking into consideration air resistance. This means that guide wires will generally be needed to ensure that the package impacts in the desired spot and with the correct orientation. Guided free fall will mean that friction has to be taken into account through an even greater release height to ensure the speed at impact is correct. Techniques that utilize additional sources of energy to achieve speed and orientation reliability may also be used. These techniques include rocket sleds, cable pulldown and airgun facilities.

737.13. Additionally, useful information is provided in paras 701.1–701.25 and 727.6–727.11.

737.14. For a package containing fissile material in quantities not excepted by para. 674, the term ‘maximum damage’ should be taken as the damaged condition that will result in the maximum neutron multiplication factor.

REFERENCES TO SECTION VII

- [1] BJORKMAN, G., “The effect of gaps on the impact response of a cask closure lid”, ASME PVP 2009-77800 (Pressure Vessels and Piping Conference), Prague, Czech Republic (2009).
- [2] WILLE, F., BALLHEIMER, V., QUERCETTI, T., STERTHAUS, J., “Consideration of gaps between content and lid within package design assessment”, RAMTrans 2015 (Radioactive Materials Transport and Storage Conference and Exhibition), Oxford, UK (May 2015).
- [3] WILLE, F., BALLHEIMER V., DROSTE, B., Suggestions for correct performance of IAEA 1m puncture bar drop test with reduced scale packages considering similarity theory aspects, *Packag. Transp. Storage Sec. Radioact. Mat.* **18** 2 (2007)111–116.
- [4] LE MAO, S., MOUTARDE, M., LIZOT, M.-T., SERT, G., “IRSN’s experience feedback list for the transport package design safety appraisals”, *Packaging and Transportation of Radioactive Materials, PATRAM 2007* (Proc. Int. Symp. Miami, 2007), Intitute of Nuclear Materials Management, Deerfield, IL (2007).
- [5] INTERNATIONAL ORGANIZATION FOR STANDARDIZATION, Radiation Protection, Sealed Radioactive Sources — General Requirements and Classification, ISO 2919-2012, ISO, Geneva (2012).
- [6] INTERNATIONAL ORGANIZATION FOR STANDARDIZATION, Radiation Protection — Sealed Radioactive Sources — Leakage Test Methods, ISO 9978:1992(E), ISO, Geneva (1992).
- [7] AMERICAN NATIONAL STANDARDS INSTITUTE, American National Standard for Leakage Tests on Packages for Shipment, ANSI N14.5-2014, ANSI, New York (2014).
- [8] INTERNATIONAL ORGANIZATION FOR STANDARDIZATION, Safe Transport of Radioactive Material — Leakage Testing on Packages, ISO 12807:2018, ISO, Geneva (2018).
- [9] DROSTE, B., et al., “Evaluation of safety of casks impacting different types of targets”, *The 12th Conference on Packaging and Transportation of Radioactive Materials, PATRAM 98* (Proc. Int. Symp. Paris, 1998), Vol. 3, Institut de protection et de sûreté nucléaire, Paris (1998) 1343–1351.
- [10] INTERNATIONAL ATOMIC ENERGY AGENCY, Transport Packaging for Radioactive Materials (Proc. Sem. Vienna, 1976), IAEA, Vienna (1976).

- [11] Packaging and Transportation of Radioactive Materials (PATRAM), Proc. Symp.: (Albuquerque, NM, 1965, Sandia Natl Labs, Albuquerque, NM (1965); Gatlinburg, TN, 1968, United States Atomic Energy Commission, Oak Ridge, TN (1968); Richland, WA, 1971, United States Atomic Energy Commission, Oak Ridge, TN (1971); Miami Beach, FL, 1974, Union Carbide Corp., Nuclear Division, Oak Ridge, TN (1975); Las Vegas, NV, 1978, Sandia Natl Labs, Albuquerque, NM (1978); Berlin (West), 1980, Bundesanstalt für Materialprüfung, Berlin (1980); New Orleans, LA, 1983, Oak Ridge Natl Lab., Oak Ridge, TN (1983); Davos, 1986, IAEA, Vienna (1987).
- [12] INTERNATIONAL ORGANIZATION FOR STANDARDIZATION, Nuclear Energy — Packaging of Uranium Hexafluoride (UF₆) for Transport, ISO 7195:2005, ISO, Geneva (2005).
- [13] INTERNATIONAL ATOMIC ENERGY AGENCY, Directory of Transport Packaging Test Facilities, IAEA-TECDOC-295, IAEA, Vienna (1983).
- [14] 2001 Directory of Test Facilities for Radioactive Materials Transport Packages, Int. J. Radioact. Mater. Transp., Special Issue **12** 2–3 (2001).
- [15] UNITED NATIONS, Recommendations on the Transport of Dangerous Goods, Model Regulations, ST/SG/AC.10/1/Rev.19, UN, 2 vols, New York and Geneva (2015).
- [16] CLARKE, R.K., FOLEY, J.T., HARTMAN, W.F., LARSON, D.W., Severities of Transportation Accidents, Rep. SLA-74-0001, Sandia Natl Labs, Albuquerque, NM (1976).
- [17] DENNIS, A.W., FOLEY, J.T., HARTMAN, W.F., LARSON, D.W., Severities of Transportation Accidents Involving Large Packages, Rep. SLA-77-0001, Sandia Natl Labs, Albuquerque, NM (1978).
- [18] McCLURE, J.D., An Analysis of the Qualification Criteria for Small Radioactive Material Shipping Packages, Rep. SAND 76-0708, Sandia Natl Labs, Albuquerque, NM (1977).
- [19] McCLURE, J.D., et al., “Relative response of Type B packagings to regulatory and other impact test environments”, Packaging and Transportation of Radioactive Materials, PATRAM 80 (Proc. Int. Symp. Berlin, 1980), Bundesanstalt für Materialprüfung, Berlin (1980).
- [20] BLYTHE, R.A., MILES, J.C., HOLT, P.J., “A study of the influence of target material on impact damage”, Packaging and Transportation of Radioactive Materials, PATRAM 83 (Proc. Int. Symp. New Orleans, 1983), Oak Ridge Natl Lab., TN (1983).
- [21] GABLIN, K.A., “Non-shielded transport package impact response to unyielding and semi-yielding surfaces”, *ibid.*
- [22] HÜBNER, H.W., MASSLOWSKI, J.P., “Interactions between crush conditions and fire resistance for Type B packages less than 500 kg”, *ibid.*

- [23] DIGGS, J.M., LEISHER, W.B., POPE, R.B., TRUJILLO, A.A., “Testing to define the sensitivity of small Type B packagings to the proposed IAEA crush test requirement”, *ibid.*
- [24] CHEVALIER, G., GILLES, P., POUARD, P., “Justification and advantages of crushing tests compared with fall tests and the modification of existing regulations”, *ibid.*
- [25] COLTON, J.D., ROMANDER, C.M., Potential Crush Loading of Radioactive Material Packages in Highway, Rail and Marine Accidents, Rep. NUREG/CR-1588, SRI International, Menlo Park, CA (1980).
- [26] OAK RIDGE NATIONAL LABORATORY, Cask Designers Guide, Rep. ORNL-NSIC-68, UC-80, Oak Ridge Natl Lab., TN (1976).
- [27] DIGGS, J.M., POPE, R.B., TRUJILLO, A.A., UNCAPHER, W.L., Crush Testing of Small Type B Packagings, Rep. SAND 83-1145, Sandia Natl Labs, Albuquerque, NM (1985).
- [28] QUERCETTI, T., BALLHEIMER, V., WIESER, G., “Analytical, numerical and experimental investigation on the impact behavior of packagings under slap down conditions”, Packaging and Transportation of Radioactive Materials, PATRAM 2001 (Proc. Int. Symp. Chicago, 2001) Bundesanstalt für Materialprüfung, Berlin (2001).
- [29] McCLURE, J.D., The Probability of Spent Fuel Transportation Accidents, Rep. SAND-80-1721, Sandia Natl Labs, Albuquerque, NM (1981).
- [30] WILMOT, E.L., McCLURE, J.D., LUNA, R.E., Report on a Workshop on Transportation Accident Scenarios Involving Spent Fuel, Rep. SAND-80-2012, Sandia Natl Labs, Albuquerque, NM (1981).
- [31] POPE, R.B., YOSHIMURA, H.R., HAMANN, J.E., KLEIN, D.E., An Assessment of Accident Thermal Testing and Analysis Procedures for a RAM Shipping Package, ASME Paper 80-HT-38, American Society for Testing and Materials, Philadelphia, PA (1980).
- [32] JEFFERSON, R.M., McCLURE, J.D., “Regulation versus reality”, Packaging and Transportation of Radioactive Materials, PATRAM 83 (Proc. Int. Symp. New Orleans, 1983), Oak Ridge Natl Lab., TN (1983).
- [33] FRY, C.J., “The use of CFD for modelling pool fires”, Packaging and Transportation of Radioactive Materials, PATRAM 92 (Proc. Int. Symp. Yokohama City, 1992), Science and Technology Agency, Tokyo (1992).
- [34] FRY, C.J., “An experimental examination of the IAEA fire test parameters”, *ibid.*
- [35] WIESER, G., DROSTE, B., “Thermal test requirements and their verification by different test methods”, *ibid.*

- [36] AMERICAN SOCIETY FOR TESTING AND MATERIALS, Standard Practice for Thermal Qualification of Type B Packages for Radioactive Material, Standard ASTM E 2230-02-08, ASTM, Philadelphia, PA (2008).
- [37] BAINBRIDGE, B.L., KELTNER, N.R., Heat transfer to large objects in large pool fires, *J. Hazard. Mater.* **20** (1988) 21–40.
- [38] KELTNER, N.R., MOYA, J.L., Defining the thermal environment in fire tests, *Fire Mater.* **14** (1989) 133–138.
- [39] BURGESS, M., FRY, C.J., Fire testing for package approval, *Int. J. Radioact. Mater. Transp.* **1** (1990) 7–16.
- [40] McCAFFERY, B.J., Purely Buoyant Diffusion Flames — Some Experimental Results, Rep. PB80-112 113, US National Bureau of Standards, Washington, DC (1979).
- [41] McADAMS, W.H., Heat Transmission, McGraw Hill, New York (1954).
- [42] INTERNATIONAL ATOMIC ENERGY AGENCY, The Air Transport of Radioactive Material in Large Quantities or with High Activity, IAEA-TECDOC-702, IAEA, Vienna (1993).
- [43] McSWEENEY, T.I., JOHNSON, J.F., An Assessment of the Risk of Transporting Plutonium Dioxide by Cargo Aircraft, Rep. BNWL-2-30 UC-71, Battelle Pacific Northwest Lab., Richland, WA (1977).
- [44] McCLURE, J.D., VON RIESEMANN, W.A., Crush Environment for Small Containers Carried on US Commercial Jet Aircraft, Report Letter, Sandia Natl Labs, Albuquerque, NM (1976).
- [45] BROWN, M.L., et al., Specification of Test Criteria for Containers to be Used in the Air Transport of Plutonium, UKAEA, London (1980).
- [46] HARTMAN, W.F., et al., “An analysis of the engine fragment threat and the crush environment for small packages carried on US commercial jet aircraft”, *Packaging and Transportation of Radioactive Materials, PATRAM 78* (Proc. Int. Symp. New Orleans, 1978), Sandia Natl Labs, Albuquerque, NM (1978).
- [47] NUCLEAR REGULATORY COMMISSION, Qualification Criteria to Certify a Package for Air Transport of Plutonium, Rep. NUREG/0360, NRC, Washington, DC (1978).
- [48] WILKINSON, H.L., “A study of severe aircraft crash environments with particular reference to the carriage of radioactive material”, *SARSS 89* (Proc. Symp. Bath, UK, 1989), Elsevier, Amsterdam and New York (1989).
- [49] BONSON, L.L., Final Report on Special Impact Tests of Plutonium Shipping Containers: Description of Test Results, Rep. SAND76-0437, Sandia Natl Labs, Albuquerque, NM (1977).

- [50] McWHIRTER, M., et al., Final Report on Special Tests of Plutonium Oxide Shipping Containers to FAA Flight Recorder Survivability Standards, Rep. SAND75-0446, Sandia Natl Labs, Albuquerque, NM (1975).
- [51] STRAVASNIK, L.F., Special Tests for Plutonium Shipping Containers 6M, SP5805 and L-10, Development Rep. SC-DR-72059, Sandia Natl Labs, Albuquerque, NM (1972).
- [52] BROWN, M.L., et al., Specification of Test Criteria for Containers to be Used in the Air Transport of Plutonium, Rep. EUR 6994 EN, CEC, Brussels and Luxembourg (1980).
- [53] McCLURE, J.D., LUNA, R.E., "An analysis of severe air transport accidents", Packaging and Transportation of Radioactive Materials, PATRAM 89 (Proc. Int. Symp. Washington, DC, 1989), Oak Ridge Natl Lab., TN (1989).
- [54] DEVILLERS, C., et al., "A regulatory approach to the safe transport of plutonium by air", *ibid.*

Section VIII

APPROVAL AND ADMINISTRATIVE REQUIREMENTS

GENERAL

801.1. The Transport Regulations distinguish between cases where the transport can be made without competent authority package design approval and cases where such approval is required. In both cases, the Transport Regulations place primary responsibility for compliance on the consignor and on the carrier. The consignor should be able to provide documentation to demonstrate to the competent authority, for example, by calculation or by test report, that the package design fulfils the requirements of the Transport Regulations. The package designer should compile a package design safety report addressing all the regulatory requirements in a systematic manner and should issue the consignor with a certificate of compliance that summarizes the regulatory compliance of the package.

801.2. The ‘relevant competent authority’ may also include the competent authorities of countries en route.

801.3. In the case of packages that do not require competent authority approval, some form of ‘certificate of compliance’ should be applied. Such certificates of compliance should include the following information:

- (a) Type of package.
- (b) Identification of the packaging.
- (c) The issue date and an expiry date.
- (d) Any restriction on the modes of transport, if appropriate.
- (e) A list of applicable national and international regulations, including the edition of the Transport Regulations and the relevant paragraphs that the package design complies with and reference to documents demonstrating compliance.
- (f) The following statement:

“This certificate does not relieve the consignor from compliance with any requirement of the government of any country through or into which the package will be transported.”
- (g) A description of the packaging by reference to the drawings or specification of the design. A reproducible illustration, not larger than 21 cm × 30 cm, showing the make-up of the package should also be provided, accompanied by a brief description of the packaging, including materials of manufacture, gross mass, general outside dimensions and appearance.
- (h) Specification of the design by reference to the drawings.
- (i) A specification of the allowed radioactive content, including any restrictions on the radioactive contents that might not be obvious from the nature of the packaging. This includes the physical and chemical forms, the activities involved (including those of the various isotopes, if appropriate), amounts in grams, and whether special form radioactive material is present.
- (j) Reference to handling, packing and maintenance instructions.

(k) A specification of the applicable management system, as required in para. 306.

(l) Any emergency arrangements deemed necessary.

(m) Signature and identification of the person responsible for certifying the compliance.

802.1. See paras 204.1–204.3 and 205.1.

802.2. When competent authority approval is required, an independent assessment by the competent authority should be undertaken, as appropriate, in respect of special form or LDRM, packages containing 0.1 kg or more of uranium hexafluoride, packages containing fissile material, fissile material to be exempted under para. 417(f), Type B(U) and Type B(M) packages, Type C packages, special arrangements, certain shipments, RPPs for special use vessels and the calculation of unlisted A_1 and A_2 values, unlisted activity concentrations for exempt material and unlisted activity limits for exempt consignments.

802.3. Regarding the requirement for competent authority approval for packages designed to contain fissile material, paras 417, 674 and 675 exclude certain packages from those requirements that apply specifically to fissile material. However, all relevant requirements that apply to the radioactive, non-fissile properties of the package contents still apply.

802.4. The relationship between the competent authority and the applicant has to be clearly understood. It is the applicant's responsibility to demonstrate compliance with the applicable requirements. The competent authority's responsibility is to judge whether or not the information submitted adequately demonstrates such compliance. The competent authority should be free to check statements, calculations and assessments made by the applicant, even, if necessary, by performing independent calculations or tests. The competent authority should not make the case for the applicant; however, this does not preclude it from providing advice to the applicant, without commitment, as to what is likely to be an acceptable way of demonstrating compliance.

802.5. Further details of the role of the competent authority can be found in regulations issued nationally or by the international transport organizations.

802.6. The applicant should contact the competent authority during the preliminary design stage to discuss the implementation of the relevant design principles and to establish both the approval procedure and the actions that should be carried out.

802.7. Experience has shown that many applicants make their first submission in terms of a specific and immediate need that is rather narrow in scope, and then later make several requests for amendments to the approval certificate as they attempt to expand its scope to use the packaging for other types of material and/or shipment. Whenever possible, applicants should be encouraged to make their first submission a general case that anticipates their future needs. This will make the application and approval system operate more efficiently. Additionally, in some cases, it is mutually advantageous for the prospective applicant and the competent authority to discuss a proposed application in outline before it is formally submitted in detail.

802.8. Upon submission of detailed information about the package design and the shipment by the applicant, the competent authority may issue a single certificate combining package design and shipment approval certificates, if it is considered reasonable.

802.9. Further guidance is given in Annex II of IAEA Safety Standards Series No. TS-G-1.5, Compliance Assurance for the Safe Transport of Radioactive Material [1].

APPROVAL OF SPECIAL FORM RADIOACTIVE MATERIAL AND LOW DISPERSIBLE RADIOACTIVE MATERIAL (LDRM)

803.1. The design for special form radioactive material is required to receive unilateral competent authority approval prior to transport, while the design for LDRM requires multilateral approval. Paragraph 803 specifies the minimum information to be included in an application for approval.

803.2. A quantitative statement should be provided of any time dependent features of a special form design likely to affect its ability to meet the requirements for special form radioactive material in paras 602–604.

803.3. There might be some processes that would influence the integrity of a special form capsule. These should be taken into account in the design of the special form capsule. For example, the pressurization of a capsule may be caused by the production of gas arising from the decay of alpha isotopes.

803.4. The competent authority should be given a reasonable opportunity to observe or comment on any test that is conducted, or is planned to be conducted, to demonstrate compliance with the Transport Regulations for special form radioactive material and LDRM. The application should include a detailed report on the tests and their results.

804.1. Detailed advice on identification marks is given in paras 832.1–832.5.

APPROVAL OF PACKAGE DESIGNS

Approval of package designs to contain uranium hexafluoride

807.1. The approval of packages designed to carry non-fissile or fissile excepted uranium hexafluoride in quantities greater than 0.1 kg was introduced in the 1996 Edition of the Transport Regulations. A new category of package identification was introduced (see para. 832).

807.2. Packages that meet the requirements of paras 631–633 may still require multilateral approval for other reasons, such as the fissile nature of the material.

807.3. The competent authority should be given a reasonable opportunity to observe or comment on any test that is conducted, or is planned to be conducted, on packages containing 0.1 kg or more of uranium hexafluoride to demonstrate compliance with the Transport Regulations. The application should include a detailed report on the tests and their results.

807.4. The application for approval of designs for packages intended to contain uranium hexafluoride should include a list of all applicable requirements (by paragraph numbers of the Transport Regulations) with reference to the documents or other justifications providing demonstration of compliance with these requirements.

Approval of Type B(U) and Type C package designs

809.1. The application for approval of package designs should include a list of all applicable requirements (by paragraph number of the Transport Regulations) with reference to the documents or other justifications providing demonstration of compliance with these requirements.

809.2. The competent authority should be given a reasonable opportunity to observe or comment on any test that is conducted, or is planned to be conducted, on Type B(U) or Type C packages to demonstrate compliance with the Transport Regulations. The application should include a detailed report on the tests and their results.

809.3 As packages used for shipment after storage may have been in service for a long duration with the radioactive contents loaded, the effects of degradation mechanisms and ageing processes should be assessed in order to comply with the safety justifications throughout the storage period in order to verify transportability after storage. This may be demonstrated through periodic safety assessments together with inspection, monitoring and surveillance of the package and its operational and environmental conditions as well as maintenance during storage. Such assessments should be documented in an ageing management programme (see para. 613A.4). Examples of consideration of ageing mechanisms for a package used for shipment after storage can be found in Refs [2–7].

809.4 A gap analysis programme is required to be established. A gap analysis is a periodic assessment of whether the package design complies with the current Transport Regulations. It should consider changes of the regulations, changes in technical knowledge and changes of the state of the package design during storage, and then identify any gaps. The gap analysis programme should describe the procedure for conducting such a gap analysis. This supports the process for the renewal of the package design approval certificate and the verification of the validity of existing certificates throughout the storage period and for shipment after storage. Detailed information on the objectives of the gap analysis programme can be found in Ref. [8], and further references on gap analysis for packages used for shipment after storage can be found in Refs [9–12].

Approval of Type B(M) package designs

812.1. Information given by the applicant with regard to para. 812(a) and (b) will enable the competent authority to assess the implications of the lack of conformance of the Type B(M) design with Type B(U) requirements as well as to determine whether the proposed supplementary controls are sufficient to provide a comparable level of safety. The purpose of supplementary controls is to compensate for the safety measures that could not be incorporated into the design. Through the mechanism of multilateral approval, the design of a Type B(M) package is independently assessed by competent authorities in all countries through or into which such packages are transported.

812.2. Proposed supplementary operational controls or restrictions (i.e. other than those already required by the Transport Regulations) that are to be applied to compensate for failure to meet one or more of the requirements of paras 639, 656, 657 and 660-666 should be fully identified, described and justified. The maximum and minimum ambient conditions of temperature and insolation that are expected during transport should be identified and justified with reference to the regions or countries of use and appropriate meteorological data (see paras 667.1 and 667.2).

812.3. Where intermittent venting of Type B(M) packages is required, a complete description of the procedures and controls should be submitted to the competent authority for approval. Further advice may be found in paras 668.1–668.6.

812.4. The competent authority should be given a reasonable opportunity to observe or comment on any test that is conducted, or is planned to be conducted, on Type B(M) packages to demonstrate compliance with the Transport Regulations. The application should include a detailed report on the tests and their results.

Approval of package designs to contain fissile material

814.1. Multilateral approval is required for all package designs for fissile material (IF, AF, B(U)F, B(M)F and CF), primarily because of the nature of the criticality hazard and the importance of maintaining subcriticality at all times during transport. Moreover, the regulatory provisions for package design for fissile material allow complete freedom as to the methods, usually computational, by which

compliance is demonstrated. It is therefore necessary that competent authorities independently assess and approve all package designs for fissile material.

814.2. A package design for fissile material is required to meet the requirements regarding the radioactive properties of the package contents and the requirements regarding the fissile properties of the package contents. Regarding the radioactive properties, a package is classified in accordance with the definition of a package in para. 231. As applicable, a package design approval based on the radioactive, non-fissile properties of the package contents is required. In addition to such approval, a design approval is required relating to the fissile properties of the package contents. See paras 417, 674 and 675 for exceptions regarding requirements on package design approval for fissile material.

815.1. The information provided to the competent authority with the application for approval is required to detail the demonstration of compliance with each requirement in paras 673 and 676–685. The information should include a list of all applicable requirements (by paragraph number of the Transport Regulations) in accordance with para. 673(b)(i)–(iv), with reference to the documents or other justifications providing demonstration of compliance with these requirements, and should include the items specifically quoted in the competent authority approval certificate as detailed in para. 838(n). Appropriate information on any experiments, calculations or reasoned arguments used to demonstrate the subcriticality of the individual package or of arrays of packages should be included. The applicant should be aware that they should seek guidance from the competent authority in the jurisdiction in which they are making the application.

TRANSITIONAL ARRANGEMENTS

Packages not requiring competent authority approval of design under the 1985, 1985 (As Amended 1990), 1996 Edition, 1996 Edition (Revised), 1996 (As amended 2003), 2005, 2009 and 2012 Editions of the Transport Regulations

819.1. Following the adoption of the 1985 Edition of the Transport Regulations, packages not requiring approval of design by the competent authority based on the 1973 Edition of the Transport Regulations and the 1973 (As Amended) Edition of the Transport Regulations could no longer be used. Continued operational use of such packages required either that the design be reviewed against the requirements of the 1985 Edition of the Transport Regulations, or that shipments be reviewed and approved by the competent authority as special arrangements, although this was not explicitly stated in the Transport Regulations.

819.2. Paragraph 819 was introduced into the 1996 Edition of the Transport Regulations and further revised in later editions to allow such existing packagings to continue in use for a limited and defined period of time following publication, during which time the designs might be reviewed and, if necessary, modified, to ensure they fully met the requirements of the latest edition of the Transport Regulations. Where such review and/or modification proves impractical, the transition period is intended to allow time for package designs to be phased out and new package designs meeting the requirements of the latest edition of the Transport Regulations to be phased in. Packages prepared in accordance with the 1985 or later editions of the Transport Regulations are sometimes stored for many years prior to further shipment. This may be particularly applicable in the case of industrial or Type A packages containing radioactive waste and awaiting shipment to intermediate or final storage repositories. Paragraph 819 allows such packages, prepared during a defined period of time and when properly maintained and inspected, to be transported in the future on the basis of compliance with the 1985 or later edition of the Transport Regulations. In the 2018 Edition of the Transport Regulations, additional transitional

provisions were added for the 1996 Edition, 1996 Edition (Revised), 1996 (As amended 2003), 2005, 2009 and 2012 Edition of the Transport Regulations.

819.3. Paragraph 819 emphasizes the requirement to apply management system measures, in accordance with the current edition of the Transport Regulations, to ensure that such packages only remain in use where they continue to meet the original design intent or regulatory requirements. This can best be achieved by ensuring that the latest management system measures are applied to post-manufacturing activities, such as servicing, maintenance, modification and use of such packages.

819.4. The reference to Section IV of the current edition of the Transport Regulations is included to ensure that only the most recent radiological data (as reflected in A1 and A2 values) are used to determine package contents and other related limits. It should be noted that the scope of the transitional arrangements of the Transport Regulations only extends to the requirements for certain packagings and packages. In all other aspects, for example, concerning general provisions, the requirements and controls for transport, including consignment and conveyance limits, and approval and administrative requirements, the requirements of the current edition of the Transport Regulations apply.

819.5. Any revision to the original package design, or increase in activity of the contents, or addition of other types of radioactive material, which would significantly and detrimentally affect safety, as determined by the package owner in consultation with the package designer, will require the design to be reassessed against the requirements of the current edition of the Transport Regulations. This could include such items as an increase in the mass of the contents, changes to the closure, changes to any impact limiters, changes to the thermal protection or shielding and changes to the contents.

Package designs approved under the 1985, 1985 (As Amended 1990), 1996 Edition, 1996 Edition (Revised), 1996 (As amended 2003), 2005, 2009 and 2012 Editions of the Transport Regulations

820.1. Following the adoption of the 2018 Edition of the Transport Regulations, packages requiring approval of design by the competent authority (Type B, Type B(U), Type B(M) packages and package designs for fissile material) based on the 1973 Edition of the Transport Regulations and the 1973 (As Amended) Edition of the Transport Regulations can no longer be used. Continued operational use of such packages required either that the design be reviewed against the requirements of the current edition of the Transport Regulations, or that shipments be reviewed and approved by the competent authority as special arrangements.

820.2. Packages requiring approval of design by competent authority based on previous editions of the Transport Regulations are permitted to continue in use, subject to certain limitations. This provision, known colloquially as ‘grandfathering’, was introduced into the 1985 Edition of the Transport Regulations to ease their transition. This allowed the continued use of packages, provided that they were properly maintained and continued to meet their original design intent, up to the end of their useful design lives. It also provided for a period of time following publication, during which the designs could be reviewed and, if necessary, modified, to ensure that packages met the requirements of the current edition of the Transport Regulations in full. Where such review and/or modification proved impractical, the transition period allowed time for packages to be phased out and new designs meeting the requirements of the current edition of the Transport Regulations to be phased in.

820.3. The 1973 and 1973 (As Amended) Editions of the Transport Regulations only required quality assurance programmes (now referred to as the management system)² to be established for the manufacture of packagings. The 1985 Edition of the Transport Regulations properly identified the need for quality assurance programmes to cover all aspects of transport from design, manufacture, testing,

documentation, use, maintenance and inspection of all packages, to actual transport and in-transit storage operations. Under the 2018 Edition of the Transport Regulations, packagings manufactured to a package design approved under the provisions of the 1973 or 1973 (As Amended) Editions of the Transport Regulations can no longer be used.

820.4. When considering the grandfathered approvals, the ‘applicable requirements’ of paragraph 306 will relate to (a) the quality assurance programmes (now referred to as the management system) in place at the time of the original manufacture of the packaging, and (b) those parts of the management system addressing current transport activities, such as use, inspection, maintenance and servicing, as well as transport and in-transit storage operations. The management system arrangements covering activities in (b) should meet the current national and/or international standards for a management system as agreed by the competent authority.

820.5. The reference to paragraphs and sections of the current edition of the Transport Regulations is included to ensure that the requirements on the management system (para. 306), the activity limits and the classification provisions (Section IV), including the most recent radiological data (as reflected in the A₁ and A₂ values); the requirements and controls for transport (Section V) and, when applicable, the requirements for fissile material transported by air (para. 683) are used to determine package contents and other related limits. It should be noted that the scope of the transitional arrangements of the Transport Regulations only extends to the requirements for certain packagings and packages. In all other aspects, for example, concerning general provisions, the requirements and controls for transport, including consignment and conveyance limits, and approval and administrative requirements, the provisions of the current Edition of the Transport Regulations apply. The most recent requirements relating to fissile exceptions (paras 417, 674 and 675) also need to be used.

² The term ‘management system’ is now used in place of ‘quality assurance’ in current editions of the Transport Regulations and associated Safety Guides.

820.6. In the process of developing the 2018 Edition of the Transport Regulations, it was determined that there was no need for an immediate change following their adoption, but that changes aiming at a long term improvement of safety in transport were justified. Therefore, it was also decided to accept continued operational use of certain packages designed and approved under the 1985, 1985 (As Amended 1990), 1996 Edition, 1996 Edition (Revised), 1996 (As amended 2003), 2005, 2009 and 2012 Editions of the Transport Regulations. The continued use of existing packagings manufactured to a package design approved under the provisions of the 1967, 1973 or 1973 (As Amended) Editions of the Transport Regulations was considered to be no longer necessary or justified.

820.7. The continued use of approved packages meeting the requirements of the 1985, 1985 (As Amended 1990), 1996 Edition, 1996 Edition (Revised), 1996 (As amended 2003), 2005, 2009 and 2012 Editions of the Transport Regulations is subject to multilateral approval, in order to permit the competent authorities to establish a framework within which continued use may be approved. Additionally, no new manufacture of packagings to such designs is permitted to commence. This transition period was determined on the basis of an assessment of the time needed to incorporate the 2018 Edition of the Transport Regulations into national and international regulations, taking into consideration the experience gained during implementation of the transitional arrangements of the 1996 Edition of the Transport Regulations.

820.8 For any revision to the original package design, or increase in activity of the contents, or addition of other types of radioactive material, which would significantly and detrimentally affect safety, as determined by the competent authority, the design should be reassessed and approved against the requirements of the current Edition of the Transport Regulations. Such factors could include an increase in the mass of the contents, changes to the closure, changes to any impact limiters, changes to the thermal protection or shielding and changes in the form of the contents.

820.9 When applying para. 820, the original competent authority identification mark and the design type codes, assigned by the original competent authority of design, should be retained both on the packages and on the competent authority certificates of design approval, notwithstanding that these packages become subject to multilateral approval of design. This means that packages originally designated Type B(U)-85 or Type B(U)F-85 under the 1985 Edition of the Transport Regulations should not be redesignated Type B(M) or Type B(M)F when used under the provisions of para. 820. This is to ensure that such packages can be clearly identified as packages grandfathered under the provisions of para. 820, having been originally approved under the 1985 Edition of the Transport Regulations.

820.10 See paras 832.2 and 832.3.

Special form radioactive material approved under the 1985, 1985 (As Amended 1990), 1996, 1996 Edition (Revised) and 1996 (As Amended 2003), 2005, 2009 and 2012 Editions of the Transport Regulations

823.1. Paragraph 823 provides transitional arrangements for special form radioactive material, the design of which is also subject to competent authority approval. It emphasizes the need to apply management system measures to ensure that such special form radioactive material remains in use only where it continues to meet the original design intent or regulatory

requirements. This can best be achieved by ensuring that the latest management system measures are applied to post-manufacturing activities such as servicing, maintenance, modification and use of such special form material. It should be noted that the scope of the transitional arrangements of the Transport Regulations only extends to the requirements for certain special form radioactive material. In all other aspects, for example, concerning general provisions, the requirements and controls for transport, including consignment and conveyance limits, and approval and administrative requirements, the requirements of the current Edition of the Transport Regulations apply.

823.2. In the process of developing the 2018 Edition of the Transport Regulations it was determined that there was no need for an immediate change following their adoption, but that changes aiming at a long term improvement of safety in transport were justified. Therefore, it was also decided to accept continued operational use of special form radioactive material designed and approved under the 1985 and 1985 (As Amended 1990), 1996, 1996 (Revised) and 1996 (As Amended 2003), 2005, 2009, and 2012 Editions of the Transport Regulations. However, no new manufacture of such special form radioactive material is permitted to commence. The continued use of existing special form radioactive material approved under the provisions of the 1967, 1973 or 1973 (As Amended) Editions of the Transport Regulations was considered to be no longer necessary or justified.

823.3. See paras 832.2 and 832.3.

NOTIFICATION AND REGISTRATION OF SERIAL NUMBERS

824.1. The competent authority should monitor specific aspects associated with the design, manufacture and use of packagings within its compliance assurance programme (see para. 307). To verify adequate performance, the serial number of all packagings manufactured to a design approved by a competent authority is required to be made available to the competent authority. The competent authorities should maintain a register of the serial numbers.

824.2. Packagings manufactured to a package design approved for continued use under the grandfather provisions in para. 820 are also to be assigned a serial number. The serial number and competent authority knowledge of this serial number are essential in that the number establishes the means to positively identify which individual packagings are subject to the respective grandfather provision.

824.3. The packaging serial number should uniquely identify each packaging manufactured. The appropriate competent authority is to be informed of the serial number. The term 'appropriate' has a broad interpretation and could pertain to any of the following:

- (a) The country where the package design originated;
- (b) The country where the packaging was manufactured;
- (c) The country or countries where the package is used.

In the case of packagings manufactured to a package design approved for continued use under para. 820, all competent authorities involved in the multilateral approval process should receive information on packaging serial numbers.

APPROVAL OF SHIPMENTS

825.1. Where shipment approvals are required, such approvals have to cover the entire movement of a consignment from origin to destination. If the consignment crosses a national border, the shipment approval is required to be multilateral (i.e. the shipment is required to be approved by the competent authority of the country in which the shipment originates and by the competent authorities of all the countries through or into which the consignment is transported). The purpose of the requirement for multilateral approval is to enable all of the competent authorities concerned to judge the need for any special controls to be applied during transport.

825.2. Each requirement in para. 825 should be applied separately. For example, a consignment of a vented Type B(M) package containing fissile material may need shipment approval in accordance with para. 825(a) and (c).

825.3. The need to apply para. 825 is governed by the actual contents of the package to be transported. For example, when a Type B(M) packaging, for which the package design approval certificate gives the permitted contents as Co-60 limited to 1600 TBq, is used for shipment of only 400 TBq of Co-60, no shipment approval is required since 400 TBq is less than 1000 TBq.

825.4. The intention of para. 825(c) is for the shipment approval requirements to apply only to those cases where the sum of the CSIs in a hold, compartment or defined deck area of a seagoing vessel exceeds 50. The sum of the CSIs for the total vessel is not limited to 50 because the 6 m separation requirement applies, and the hold, compartment or defined deck area may be considered as separate conveyances.

826.1. In accordance with para. 802(a)(iv)–(vii), design approvals are required for defined package designs. Some of those packages may be transported without additional shipment approval, while for others, such approval is required (see para. 825). In some cases, an additional shipment approval is required because operational or other controls may be necessary and those controls may be dependent on the actual package contents. In situations where the need for controls during shipment can be determined at the design review and approval stages, the need to review single shipments does not exist. In such cases, the package design and shipment approvals may be combined into one approval document.

826.2. The Transport Regulations conceptually differentiate between design approvals and shipment approvals. A shipment approval may be incorporated into the corresponding design approval certificate, and if this is done, care should be exercised to define clearly the dual nature of the approval certificate and to apply the proper type codes. For type codes, see para. 832.

827A.1 For recommendations on the transport plan see 520.2 to 520.4.

APPROVAL OF SHIPMENTS UNDER SPECIAL ARRANGEMENT

829.1. Although an approval of a shipment under special arrangement will require consideration of both the shipment procedures and the package design, the approval is conceptually a shipment approval. Further guidance may be found in paras 310.1–310.4.

830.1. The level of safety necessary in special arrangement shipments is normally achieved by imposing operational controls to compensate for any non-conformances in the packaging or the shipping procedures. Some of the operational controls that may be effectively employed are as follows:

- (a) Exclusive use of vehicle (see para. 221).
- (b) Escorting the shipment. The escort is normally a radiation protection specialist who is equipped with radiation monitoring instruments and is familiar with emergency procedures enabling the specialist, in the event of an accident or other abnormal event, to identify quickly any radiation and contamination hazards present and to provide appropriate advice to the civil authorities. For road transport, the escort, whenever possible, should travel in a separate vehicle so as to avoid the risk of being incapacitated by the same accident. The escort should also be equipped with stakes, ropes and signs to cordon off an accident area, a fire extinguisher to control minor fires, and a communications system. If considered prudent, the radiation protection specialist could be accompanied by police and fire department escorts.
- (c) Routing of the shipment may be controlled in order to select the potentially least hazardous routes and, if possible, to avoid areas of high population density and possible hazards, such as steep gradients and railway level crossings.
- (d) Timing of shipment may be controlled to avoid busy periods such as rush hours and weekend traffic peaks.
- (e) Shipments should be made directly (i.e. without stopover or transshipment), wherever possible.
- (f) Transport vehicle speeds may be limited, particularly if the impact resistance of the packaging is low and if the slower speed of the transport vehicle would not cause additional hazards (such as collisions involving faster moving vehicles).
- (g) Consideration should be given to notifying the emergency services (police and fire and rescue) in advance.
- (h) Applicable emergency procedures need to take into account the contingencies resulting from the special arrangement shipment being involved in an accident (see para. 554(c)).
- (i) Ancillary equipment such as package to vehicle tie-down or shock absorber systems and other protective devices or structures should be used, where necessary, as compensatory safety arrangements.

COMPETENT AUTHORITY APPROVAL CERTIFICATES

Competent authority identification marks

832.1. Type codes are based on the use of several indicators intended to provide information quickly on the type of package or shipment in question. The indicators provide information on package design characteristics (e.g. Type B(U), Type B(M) or Type C), on the availability of a multilateral package design approval certificate for fissile materials, and on other specific aspects of the approval certificate (e.g. special arrangement, shipment, special form, LDRM, non-fissile or fissile excepted uranium hexafluoride contents, fissile excepted material). Consequently, the appearance of, for example, B(U)F in the identification mark does not necessarily indicate the presence of fissile material in a particular package, only the possibility that it might be present.

832.2. It is essential that easy means are available, preferably in the identification mark, for determining under which edition of the Transport Regulations the original package design approval was issued. With the 1985 Edition of the Transport Regulations, this was achieved by adding the symbol ‘-85’ to the identification mark, which was then changed to ‘-96’ when the 1996 Edition of the Transport Regulations was issued. The identification mark including ‘-96’ continued through the 1996 (Revised) and 1996 (As Amended 2003), 2005, 2009, and 2012 Editions of the Transport Regulations. No symbol for the year means that the design is approved under the requirements of the current edition of the Transport Regulations.

Example:

Edition of Transport Regulations	Package design identification mark
1985	A/132/B(U)-85, or A/132/B(M)-85
1996	A/132/B(U)-96, or A/132/B(M)-96
2018	A/132/B(U), or A/132/B(M)

832.3. The procedure of adding the same symbol ‘-96’ to the type code for the 1996 through the 1996 (Revised) and 1996 (As Amended 2003), 2005, 2009, and 2012 Edition of the Transport Regulations was justified because no significant safety related changes to design or test requirements for packages, special form radioactive material and low dispersible radioactive material were introduced in the editions after the 1996 Edition of the Transport Regulations until the 2012 Edition. All designs with the addition of ‘-85’ or ‘-96’ are subject to the provisions of transitional arrangements in accordance with paras 820–823, respectively, and can be clearly identified as such.

CONTENTS OF CERTIFICATES OF APPROVAL

Certificates of approval for special form radioactive material and low dispersible radioactive material

834.1. The purpose of the careful description of approval certificate content is twofold. It aims at providing assistance to competent authorities in designing their certificates, and it facilitates any checking of certificates because the information they contain is standardized.

834.2. The Transport Regulations prescribe the basic information in certificates of approval and a competent authority identification mark system. To follow these prescriptions contribute to achieve international uniformity of certification. In addition to the applicable national regulations and the relevant international regulations, each certificate is required to make reference to the appropriate edition of the Transport Regulations because this is the internationally recognized and known standard. The international vehicle registration (VRI) code [13], which is used in competent authority identification marks, is given in Table 4. VRI represents the distinguishing sign used internationally on road traffic vehicles.⁵

TABLE 4. LIST OF VRI CODES COUNTRY	BY	VRI code	TABLE 4. LIST OF VRI CODES COUNTRY	BY	VRI code
Afghanistan		AFG	Belize (former British Honduras)		BH ^a
Albania		AL	Benin		DY
Algeria		DZ	Bolivia		BOL
Andorra		AND	Bosnia & Herzegovina		BIH
Angola		AO	Botswana		BW
Argentina		RA	Brazil		BR
Armenia		AM	Brunei		BRU
Australia		AUS	Bulgaria		BG
Austria		A	Burkina Faso		BF
Azerbaijan		AZ	Burundi		RU
Bahamas		BS	Cambodia		KH ^b
Bahrain		BRN	Cameroon		CAM
Bangladesh		BD	Canada		CDN
Barbados		BDS	Central African Republic		RCA
Belarus		BY	Chile		RCH
Belgium		B	Chad		TCH/TD

⁵ Distinguishing sign of the State of registration used on motor vehicles and trailers in international road traffic, e.g. in accordance with the Geneva Convention on Road Traffic of 1949 or the Vienna Convention on Road Traffic of 1968

TABLE 4. LIST OF VRI CODES COUNTRY	BY	VRI code	TABLE 4. LIST OF VRI CODES COUNTRY	BY	VRI code
China, People's Republic of		RC	Gambia		WAG
Colombia		CO	Georgia		GE
Congo		RCB	Germany		D
Costa Rica		CR	Ghana		GH
Cote d'Ivoire		CI	Greece		GR
Croatia		HR	Grenada (Windward Islands)		WG
Cuba		CU ^c	Guatemala		GCA
Cyprus		CY	Guinea		RG
Czech Republic		CZ	Guyana		GUY
Democratic Republic of the Congo		ZRE	Haiti		RH
Denmark		DK	Holy See		V
Faroe Islands		FO	Hong Kong		HK
Dominica (Windward Islands)		WD	Hungary		H
Dominican Republic		DOM	Iceland		IS
Ecuador		EC	India		IND
Egypt		ET	Indonesia		RI
El Salvador		ES	Iran, Islamic Republic of		IR
Eritrea		ER	Iraq		IRQ
Estonia		EST	Ireland		IRL
Eswatini		SD	Israel		IL
Ethiopia		ETH	Italy		I
Fiji		FJI	Jamaica		JA
Finland		FIN	Japan		J
France		F	Jordan		HKJ
Gabon		G	Kazakhstan		KZ

TABLE 4. LIST OF VRI CODES COUNTRY	OF BY	VRI code
Kenya		EAK
Korea, Democratic People's Republic of		KP
Kuwait		KWT
Kyrgyzstan		KG
Laos People's Democratic Republic		LAO
Latvia		LV
Lebanon		RL
Lesotho		LS
Liberia		LB
Liechtenstein		FL
Lithuania		LT
Luxembourg		L
Madagascar		RM
Malawi		MW
Malaysia		MAL
Mali		RMM
Malta		M
Marshall Islands		PC
Mauritania		RIM
Mauritius		MS
Mexico		MEX
Monaco		MC
Mongolia		MGL
Montenegro		MNE

TABLE 4. LIST OF VRI CODES COUNTRY	OF BY	VRI code
Morocco		MA
Mozambique		MOC
Myanmar		BUR
Namibia		NAM
Nauru		NAU
Nepal		NEP
Netherlands		NL
Netherlands Antilles		NA
New Zealand		NZ
Nicaragua		NIC
Niger		RN
Nigeria		WAN
Norway		N
Pakistan		PK
Panama		PA
Papua New Guinea		PNG
Paraguay		PY
Peru		PE
Philippines		RP
Poland		PL
Portugal		P
Qatar		Q
Republic of Korea		ROK
Republic of Moldova		MD ^c
Romania		RO

TABLE 4. LIST OF VRI CODES COUNTRY	OF VRI BY	VRI code
Russian Federation		RUS
Rwanda		RWA
Samoa		WS
San Marino		RSM
Saudi Arabia		SA
Senegal		SN
Serbia		SRB
Seychelles		SY
Sierra Leone		WAL
Singapore		SGP
Slovakia		SK
Slovenia		SLO
Somalia		SO
South Africa		ZA
Spain		E
Sri Lanka		CL
St Lucia (Windward Islands)		WL
St Vincent and the Grenadines (Windward Islands)		WV
State of Libya		LAR
Sudan		SUD
Surinam		SME
Sweden		S
Switzerland		CH
Syrian Arab Republic		SYR

TABLE 4. LIST OF VRI CODES COUNTRY	OF VRI BY	VRI code
Tajikistan		TJ
Thailand		T
The F.Y.R. of Macedonia		MK
Togo		TG
Trinidad and Tobago		TT
Tunisia		TN
Turkey		TR
Turkmenistan		TM
Uganda		EAU
Ukraine		UA
United Arab Emirates		SV
United Kingdom		GB
Alderney		GBA
Gibraltar		GBZ
Guernsey		GBG
Isle of Man		GBM
Jersey		GBJ
United Republic of Tanzania:		
Tanganyika		EAT
Zanzibar		EAZ
United States of America		USA
Uruguay		ROU
Uzbekistan		UZ
Venezuela		YV
Vietnam		VN

TABLE 4. LIST OF VRI CODES COUNTRY	BY	VRI code
Virgin Islands		BVI
Yemen		YAR

TABLE 4. LIST OF VRI CODES COUNTRY	BY	VRI code
Zambia		RNR
Zimbabwe		ZW

- ^a After independence, the change of the name of the State was not notified in the 1949 Convention on Road Traffic.
- ^b Cambodia was formerly known as Democratic Kampuchea.
- ^c The distinguishing sign was not notified to the United Nations Secretary General.

Certificates of approval for special arrangement

836.1. As discussed in para. 418.1, during preparation of the certificate, care should be taken with regard to the authorized quantity, type and form of the contents of each package because of the potential impact on criticality safety.

Any special inspections or tests of the contents to confirm the characteristics of the contents prior to shipment should be specified in the certificate. This is of particular importance for any removable neutron poison or other criticality control feature that will be loaded in the package prior to shipment (see paras 503.4–503.5). Where appropriate, the criteria that the measurement needs to satisfy should be specified or referenced in the approval certificate.

836.2. Any special loading arrangement of the packages that should be adhered to or avoided should be noted in the special arrangement certificate.

Certificates of approval for shipment

837.1. See para. 836.1.

837.2. Packages that contain fissile material are excepted from the requirements of paras 676–685 if certain package and consignment requirements are met: see para. 674(a)–(d). If the packages in the consignment contain fissile material that is excepted, based on the package limits, care should be taken to ensure that the consignment limit is not exceeded. This will mean that the consignor should know the upper limit of the fissile material quantity in each package or assume that the upper limit (see para. 674(a)) is contained in each package.

Certificates of approval for package design

838.1. As discussed in para. 418.1, care should be taken with regard to the authorized quantity, type and form of the contents of each package because of the potential impact on criticality safety. Any inspections or tests of the contents that may be needed to confirm the characteristics of contents prior to shipment should be specified in the certificate. Measurements that satisfy the requirements of para. 677(b) may need to be performed prior to loading and/or shipment if the package contains irradiated nuclear fuel. The criteria that the measurements are required to satisfy should be specified or referenced in the certificate for the package (see related advisory material of para. 503.8). Similarly, if special features exclude

water in-leakage, specific inspections and/or test procedures to ensure compliance should be stated (or referenced) in the certificate.

VALIDATION OF CERTIFICATES

840.1. The approval certificate of the competent authority of the country of origin is usually the first to be issued in the series of multilateral approval certificates. Competent authorities, other than that of the country of origin, have the option of either performing a separate safety assessment and evaluation or making use of the assessment already made by the original competent authority, thus limiting the scope and extent of their own assessment.

840.2. Subsequent approval certificates may take one of two forms. First, a competent authority in a subsequent country may endorse the original certificate (i.e. agree with and endorse the original certificate, including any definition of controls incorporated in it). This is multilateral approval by validation of the original certificate. An approval by validation will not require any additional competent authority's identification mark, either in terms of certificate identification or marking on packages. Second, a competent authority may issue an approval certificate that is associated with, but separate from, the original certificate in that this subsequent certificate would bear an identification mark other than that of the original identification mark. Furthermore, in this case, packagings in use under such a multilateral approval have to be marked with the identification marks of both the original and the subsequent approval certificates (see para. 833(b)).

840.3 For a package that is intended to be used for shipment after storage, the competent authority of the country where storage takes place and where shipment after storage is initiated may be different from the country of origin of the package design. When a package design approval is withdrawn or not renewed in the country of origin of the design, the package may no longer be authorized to be transported in the country where the package is stored without package design approval granted in that country. For this reason, the competent authority concerned with storage and shipment after storage may consider issuing and maintaining its own package design approval. This may be based in part on an assessment already made by the competent authority of the country of origin of the package design, but then completed by an additional assessment addressing aspects specific to storage and shipment after storage, such as ageing management, gap analysis, requirements before shipment, requirements for shipment after storage, and various approval periods.

REFERENCES TO SECTION VIII

- [1] INTERNATIONAL ATOMIC ENERGY AGENCY, Compliance Assurance for the Safe Transport of Radioactive Material, IAEA Safety Standards Series No. TS-G-1.5, IAEA, Vienna (2009).
- [2] ERHARD, A., PROBST, U., WOLFF, D., Aging management for long-term interim storage casks, Packaging Transport Storage and Security of Radioactive Material, Vol.22 No.1, W.S. Maney & Son Ltd., Leeds, UK (2011).

- [3] CHOPRA, O. K., DIERCKS, D., et. al., Managing Aging Effects on Dry Cask Storage Systems for Extended Long-Term Storage and Transportation of Used Fuel Rev.1, FCRD-UFD-2013-000294, ANL-13/15, Argonne National Laboratory, Argonne, IL (2013).
- [4] SAEGUSA, T., Ageing management and post-storage transport of dual purpose cask for Spent Fuel, Packaging, Transport, Storage & Security of Radioactive Material, Vol.25 No.2, W. S. Maney & Son Ltd., W.S. Maney & Son Ltd., Leeds, UK (2014).
- [5] WILLE, F., WOLFF, D., et. al., German approach and feedback on experience of transportability of SNF packages after interim storage, Packaging, Transport, Storage & Security of Radioactive Material, Vol.25 No.2, W. S. Maney & Son Ltd., W.S. Maney & Son Ltd., Leeds, UK (2014).
- [6] NUCLEAR ENERGY INSTITUTE, Guidance for Operations-Based Aging Management for Dry Cask Storage, NEI 14-03 Revision 0, Washington DC (2014).
- [7] DROSTE, B., KOMANN, S., et. al., Consideration of aging mechanism influence on transport safety of dual purpose casks for spent nuclear fuel or HLW, Packaging, Transport, Storage & Security of Radioactive Material, Vol.25, No.3-4, W. S. Maney & Son Ltd., W.S. Maney & Son Ltd., Leeds, UK (2014).
- [8] INTERNATIONAL ATOMIC ENERGY AGENCY, Methodology for Preparation of a Safety Case of a Dual Purpose Cask for Storage and Transport of Spent Fuel, IAEA-TECDOC-****, IAEA, Vienna (201*) (Under publication).
- [9] HANSON, B., ALSAED, H., et. al, Gap Analysis to Support Extended Storage of Used Nuclear Fuel Rev.0, CED-USED-2011-000136 Rev.0, PNNL-20509, Pacific Northwest National Laboratory, Richland, WA (2012).
- [10] PACIFIC NORTHWEST NATIONAL LABORATORY, Review of Used Nuclear Fuel Storage and Transportation Technical Gap Analysis, FCRD-USED-2012-000215, PNNL-21596, Richland, WA (2012).
- [11] DROSTE, B., WILLE, F., Maintenance of Package Design Safety Report Effectiveness of SNF/HLW Dual Purpose Casks, Proceedings of 17th International Symposium on Packaging and Transportation of Radioactive Materials (PATRAM 2013), San Francisco, CA (2013).
- [12] KOMANN, S., WILLE, F., DROSTE, B., Gap Analysis Examples from Periodical Reviews of Transport Package Design Safety Report of SNF/HLW Dual Purpose Casks, Probabilistic Safety Assessment and Management PSAM 12, Honolulu, Hawaii (2014).
- [13] UNITED NATIONS ECONOMIC COMMISSION FOR EUROPE, Distinguishing Signs of Vehicles in International Traffic Notified to the Secretary General of the United Nations in Accordance with the 1968 Convention on Road Traffic (Article 45(4)) and the 1949 Convention on Road Traffic (Annex 4), UNECE, Geneva (2007).

Appendix I

THE Q SYSTEM FOR THE CALCULATION AND APPLICATION OF A_1 AND A_2 VALUES

INTRODUCTION

I.1. The Q system defines the ‘quantity’ limits, in terms of the A_1 and A_2 values, of a radionuclide that is allowed in a Type A package. These limits are also used for several other purposes in the Transport Regulations, such as in specifying Type B(U), Type B(M) or Type C package activity leakage limits, LSA and excepted package contents limits, and contents limits for low dispersible and special form (non-dispersible) and non-special form (dispersible) radioactive material. The ‘Q’ in the term Q system stands for ‘quantity’.

I.2. A summary of the original Q system is provided in Ref. [I.1]. The Q system was further refined by a Special IAEA Working Group in 1982. This served as the basis of the A_1 and A_2 values in the 1985 Edition of the Transport Regulations. Further information is provided in Refs [I.2–I.7].

I.3. In anticipation of the publication of the 1996 Edition of the Transport Regulations, the latest ICRP recommendations and data in the form of coefficients for dose per unit intake (dose coefficients) [I.8] were incorporated into the Q system. These results served as a basis for updating the A_1 and A_2 values. An essential part of this work entailed a re-examination of the dosimetric models used in the derivation of the Type A package contents limits. The re-examination of the earlier models resulted in the further development of the Q system, which in turn resulted in an improved method for the evaluation of the A_1 and A_2 values. The revised methods of determining A_1 and A_2 values and the results obtained are reported in this appendix. Much of the information and discussion contained in this appendix is historical, but its retention is considered to be essential for a full understanding of the advice given.

BACKGROUND

I.4. The various limits for the control of radioactive releases from transport packages prescribed in the Transport Regulations are based upon the activity contents limits for Type A packages. Type A packages are intended to provide economical transport for large numbers of low activity consignments, while at the same time achieving a high level of safety. The contents limits are set so as to ensure that the radiological consequences of severe damage to a Type A package are not unacceptable and design approval by the competent authority is not required, except for packages containing fissile material.

I.5. Activities in excess of the Type A package limits are covered in the Transport Regulations by the requirements for Type B(U) or Type B(M) packages, which do require competent authority approval. The design requirements for Type B(U) or Type B(M) packages are such as to reduce to a very low level the probability of significant radioactive release from such packages as a result of a severe accident.

I.6. Originally, radionuclides were classified into seven groups for transport purposes, each group having its Type A package contents limits for special form radioactive material and for material in all other forms. Special form radioactive material was defined as that which was non-dispersible when subject to specified tests. In the 1973 Edition of the Transport Regulations, the group classification system was developed into the A_1/A_2 system, in which

each nuclide has a Type A package contents limit, A_1 curies, when transported in special form and a limit, A_2 curies, when not in special form.

I.7. The dosimetric basis of the A_1/A_2 system originally relied upon a number of pragmatic assumptions. In calculating A_1 values, the whole body exposure was limited to 30 mSv at a distance of 3 m over a period of 3 h. Also, an intake of $10^{-6}A_2$, leading to half the annual limit on intake for a radiation worker, was assumed in the derivation of A_2 as a result of a 'median accident'. The median accident was defined arbitrarily as one which leads to complete loss of shielding and to a release of 0.1% of the package contents in such a manner that a bystander subsequently received an intake of 0.1% of this released material. . The current Q system described here includes consideration of a broader range of exposure pathways than the earlier A_1/A_2 system, but uses the same assumptions as in the Q system described in the 1985 Edition of the Transport Regulations. Many of the assumptions made are similar to those stated or implied in the 1973 Edition of the Transport Regulations, but in situations involving the intake of radioactive material use is made of new data and concepts recommended by [I.8, I.9]. In particular, pragmatic assumptions are made regarding the extent of package damage and release of contents, as discussed later, without reference to a median accident.

BASIS OF THE Q SYSTEM

I.8. Under the Q system, a number of different exposure routes is considered, each of which might lead to radiation exposure, either external or internal, to persons in the vicinity of a Type A package involved in a severe transport accident. The dosimetric routes are illustrated schematically in Fig. I.1 and lead to five contents limit values, Q_A , Q_B , Q_C , Q_D and Q_E , for external photon dose, external beta dose, inhalation dose, skin and ingestion dose due to contamination transfer, and submersion dose, respectively. Contents limits for special form alpha and neutron emitters and tritium are considered separately.

I.9. Type A package contents limits are determined for individual radionuclides, as in the 1985 Edition of the Transport Regulations. The A_1 value for special form radioactive material is the lesser of the two values, Q_A and Q_B , while the A_2 value for non-special form radioactive material is the lowest of the A_1 and the remaining Q values. Specific assumptions concerning the exposure pathways used in the derivation of individual Q values are discussed below, but all are based upon the following radiological criteria:

- (a) The effective or committed effective dose to a person exposed in the vicinity of a transport package following an accident should not exceed a reference dose of 50 mSv.
- (b) The equivalent dose or committed equivalent dose received by individual organs, including the skin, of a person involved in the accident should not exceed 0.5 Sv, or in the special case of the lens of the eye, 0.15 Sv.
- (c) A person is unlikely to remain at 1 m from the damaged package for more than 30 min.

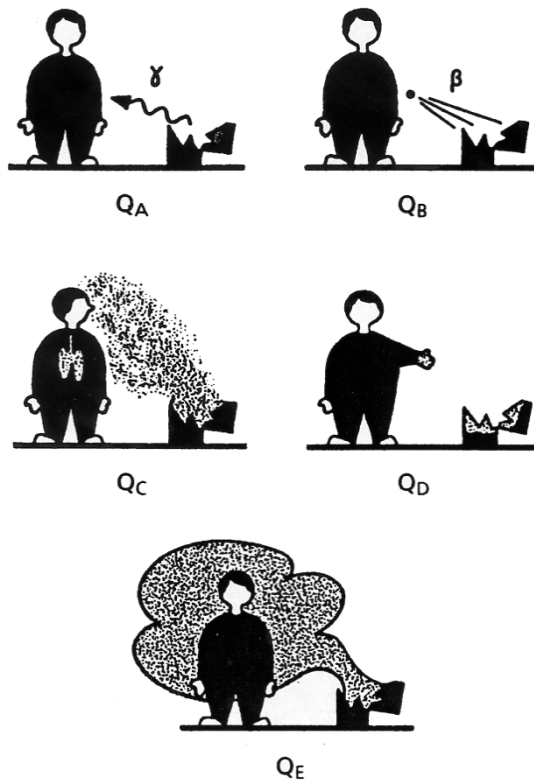

FIG. I.1. Schematic representation of exposure pathways employed in the Q system.

I.10. In the 1985 Edition of the Transport Regulations, the reference dose used in the derivation of A_1/A_2 values, of 50 mSv for the effective dose or committed effective dose to a person exposed in the vicinity of a transport package following an accident was based on the annual dose limit for radiation workers at that time. In the revised Q system, the reference dose of 50 mSv has been retained because actual accidents involving Type A packages have led to very low exposures. In choosing a reference dose, it is also important to take into account the probability of an individual being exposed as the result of a transport accident. Such exposures may, in general, be considered as ‘once in a lifetime’ exposures. Clearly, most individuals will never be exposed.

I.11. The effective dose to a person exposed in the vicinity of a transport package following an accident should not exceed 50 mSv. For calculation purposes, the person is considered to be at a distance of 1 m from the damaged package and to remain at this location for 30 min. The effective dose is the summation of the tissue equivalent doses, each multiplied by the appropriate tissue weighting factor [I.10]. The tissue weighting factors are those used in radiation protection, as given in ICRP Publication 103 [I.8], except for the seven radionuclides added in the 2018 Edition of the Transport Regulations for which data from ICRP Publication 116 [I.11] were used.

I.12. The exposure period of 30 min at a distance of 1 m is a cautious judgement of the incidental exposure of persons initially present at the scene of an accident, it being assumed that subsequent recovery operations take place under health physics supervision and control. This is considered to be more realistic than the earlier assumption of exposure for 3 h at a

distance of 3 m. Coupled with the dose limits cited above, it leads to a limiting dose rate from the damaged package for whole body neutron irradiation of 0.1 Sv/h at 1 m.

DOSIMETRIC MODELS AND ASSUMPTIONS

I.13. In this section, the dosimetric models and assumptions used in the derivation of the five Q values are described in detail. The different radiation pathways considered are outlined and the considerations associated with the methods of derivation used are discussed.

Q_A: External dose due to photons

I.14. The Q_A value for a radionuclide is determined by consideration of the whole body external radiation dose due to gamma radiation or X rays received by a person exposed near a damaged Type A package following an accident. The shielding of the package is assumed to be completely lost in the accident and the consequent dose rate at a distance of 1 m from the edge (or surface) of the unshielded radioactive material is limited to 0.1 Sv/h. It is further assumed that the damaged package may be treated effectively as a point source.

I.15. In the earlier Q system, Q_A was calculated by using the mean photon energy per disintegration taken from ICRP Publication 38 [I.12]. Furthermore, the conversion to effective dose per unit exposure free in air was approximated as 6.7 mSv/R from photon energies between 50 keV and 5 MeV.

I.16. In the revised Q system, the Q_A values have been calculated using the complete X and gamma emission spectra for the radionuclides, as given in ICRP Publication 38 [I.12], except for the seven radionuclides added in the 2018 Edition of the Transport Regulations, for which data from ICRP Publication 107 [I.13] have been used. The energy dependent relationship between effective dose and exposure free in air is that given in ICRP Publication 51 [I.14] for an isotropic radiation geometry.

I.17. The Q_A values are given by:

$$Q_A = \frac{D/t}{DRC_\gamma} \quad (I.1)$$

where

D is the reference dose of 0.05 Sv;

t is the exposure time of 0.5 h;

DRC_γ is the effective dose rate coefficient for the radionuclide;

I.18. Thus, the Q_A values are determined by:

$$Q_A(TBq) = \frac{10^{-13}}{e_{pt}} \quad (I.2)$$

where \dot{e}_{pt} is the effective dose rate coefficient for the radionuclide at a distance of 1 m ($\text{Sv} \cdot \text{Bq}^{-1} \cdot \text{h}^{-1}$).

I.19. Dose and dose rate coefficients are given in Table II.2 of Appendix II.

I.20. The dose rate coefficient has been calculated from:

$$\dot{e}_{pt} = \frac{1}{4\pi d^2} \sum_i \left(\frac{e}{X} \right)_{E_i} Y_i E_i \left(\frac{\mu_{en}}{\rho} \right)_{E_i} e^{-\mu_i d} B(E_i, d) \quad (\text{I.3})$$

where

$(e/X)_{E_i}$ is the relationship between the effective dose and exposure free in air ($\text{Sv} \cdot \text{R}^{-1}$);

Y_i is the yield of photons of energy E_i per disintegration of the radionuclide ($\text{Bq} \cdot \text{s}^{-1}$);

E_i is the energy of the photon (MeV);

$(\mu_{en}/\rho)_{E_i}$ is the mass energy absorption coefficient in air for photons of energy E_i ($\text{cm}^2 \cdot \text{g}^{-1}$);

μ_i is the linear attenuation coefficient in air for a photon of energy E_i (cm^{-1});

$B(E_i, d)$ is the air kerma buildup factor for photons of energy, E_i , and distance, d ;

I.21. The distance d is taken as 1 m. The values of $(e/X)_{E_i}$ are obtained by interpolating the data from ICRP Publication 51 [I.14], except for the seven radionuclides added in the 2018 Edition of the Transport Regulations, for which data from ICRP Publication 116 [I.11] were used. This approach is valid for photons in the range 5 keV to 10 MeV. The value of $(e/X)(e/X)_{E_i}$ depends on the assumptions regarding the angular distribution of the radiation field (the exposure geometry). However, the numerical differences between various exposure geometries are limited for example, the ratio of a rotational parallel beam to isotropic field is typically less than 1.3.

Q_B: External dose due to beta emitters

I.22. The Q_B value is determined by consideration of the beta dose to the skin of a person exposed following an accident involving a Type A package containing special form radioactive material. The shielding of the transport package is assumed to be completely lost in the accident, but the concept of a residual shielding factor for beta emitters (associated with materials such as the beta window protector, package debris) included in the 1985 Edition of the Transport Regulations is retained. This is a very conservative shielding factor of 3 for beta emitters of maximum energy ≥ 2 MeV; in the Q system, this approach is extended to include a range of shielding factors dependent on the beta energy and based on an absorber of approximately 150 mg/cm² thickness.

I.23. In the revised Q system, Q_B is calculated by using the complete beta spectra for the radionuclides of ICRP Publication 38 [I.12], except for the seven radionuclides added in the 2018 Edition of the Transport Regulations, for which data from ICRP Publication 107 [I.13] were used. The spectral data are used with data from Refs [I.15–I.17] on the skin dose rate per

unit activity of a monoenergetic electron emitter. The self-shielding of the package was taken to be a smooth function of the maximum energy of the beta spectrum, as shown in Fig. I.2.

Q_B is given by:

$$Q_B = \frac{D/t}{DRC_\beta} \quad (I.4)$$

where

D is the reference dose of 0.5 Sv;

t is the exposure time of 0.5 h;

DRC_β is the equivalent skin dose rate coefficient for the radionuclide;

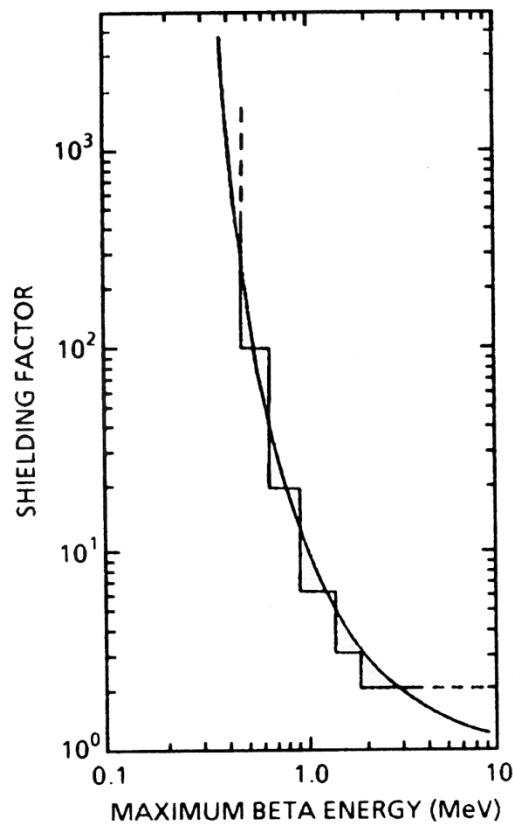

FIG. I.2. Shielding factor as a function of beta energy. Shielding factor = $e^{\mu d}$, $\mu = 0.017 \times E_{\beta_{max}}^{-1.14}$, $d = 150$ mg/cm².

I.24. Thus, the Q_B is calculated from:

$$Q_B(\text{TBq}) = \frac{1 \times 10^{-12}}{\dot{e}_\beta} \quad (\text{I.5})$$

where \dot{e}_β is the equivalent skin dose rate coefficient for beta emission at a distance of 1 m from the self-shielded material ($\text{Sv} \cdot \text{Bq}^{-1} \cdot \text{h}^{-1}$). Dose and dose rate coefficients may be found in Table II.2 of Appendix II.

$$\dot{e}_\beta = \frac{1}{\text{SF}_{\beta_{\text{max}}}} J_{\text{air}} \quad (\text{I.6})$$

I.25. The dose rate coefficient is defined as:

where

$\text{SF}_{\beta_{\text{max}}}$ is the shielding factor computed at the maximum energy of the beta spectrum;

J_{air} is the dose at 1 m per disintegration ($\text{MeV} \cdot \text{g}^{-1} \cdot \text{Bq}^{-1} \cdot \text{s}^{-1}$);

The factor J_{air} is calculated from:

$$J_{\text{air}} = \frac{n}{4\pi r^2} \int_0^{E_{\text{max}}} N(E) j(r/r_E, E) (E/r_E) dE \quad (\text{I.7})$$

where

n is the number of beta particles emitted per disintegration;

$N(E)$ is the number of electrons emitted with energy between E and $E + dE$ ($\text{Bq}^{-1} \cdot \text{s}^{-1}$);

$j(r/r_E, E)$ is the dimensionless dose distribution that represents the fraction of emitted energy deposited in a spherical shell of radius r/r_E ; as tabulated by Refs [I.16, I.17].

I.26. It should be noted that although the annual dose limit for the lens of the eye is lower than that for the skin (0.15 Sv as compared with 0.5 Sv), consideration of the depth doses in tissues for beta emitters and, in particular, absorption at the 300 mg/cm^2 depth of the sensitive cells of the lens epithelium indicates that the dose to the skin is always limiting for maximum beta energies up to approximately 4 MeV [I.18–I.20]. Consequently, specific consideration of the dose to the lens of the eye is unnecessary.

I.27. In the determination of Q values, conversion electrons are treated as monoenergetic beta particles and weighted in accordance with their yields. Annihilation radiation is not included in the evaluation of the beta dose to the skin since it contributes only an additional few per cent to the local dose to the basal layer. However, the 0.51 MeV gamma rays are included in the photon energy per disintegration used in the derivation of Q_A .

Q_C: Internal dose via inhalation

I.28. The Q_C value for non-special form radioactive material is determined by consideration of the inhalation dose to a person exposed to the radionuclide(s) released from a damaged Type A package following an accident. Compliance with the limiting doses cited earlier was ensured by restricting the intake of radioactive material under accident conditions to the annual limit on intake recommended by the ICRP at that time [I.21]. The concept of the median accident used in the 1973 Edition of the Transport Regulations is no longer used.

I.29. Under the Q system, a range of accident scenarios is considered, including that originally proposed for the derivation of Q_C, encompassing accidents occurring both indoors and out of doors and including the possible effects of fires. In the 1973 Edition of the Transport Regulations, it was assumed that 10⁻³ of the package contents might escape as a result of a median accident and that 10⁻³ of this material might be taken into the body of a person involved in the accident. This results in a net intake factor of 10⁻⁶ of the package contents and this value has been retained within the Q system. However, it is now recognized as representing a range of possible release fractions and uptake factors and it is convenient to consider intake factors in terms of these two parameters independently.

I.30. The range of release fractions now recognized under the Q system, namely, 10⁻³–10⁻², covers that assumed in the 1973 Edition of the Transport Regulations and the original proposal within the Q system. Underlying this, there is the tacit assumption, also made in the 1985 Edition of the Transport Regulations, that the likelihood of a ‘major accident’ that could cause the escape of a large fraction of the package contents, is small. This approach is borne out by the behaviour of Type A packages in severe accident environments [I.22–I.24].

I.31. Data on the respirable aerosol fractions produced under accident conditions are generally sparse and are only available for a limited range of materials. For example, for uranium and plutonium specimens under enhanced oxidation rate conditions in air and carbon dioxide, respirable aerosol fractions up to approximately 1% have been reported [I.25]. However, below this level, the aerosol fractions showed wide variations, dependent on the temperatures and local atmospheric flow conditions involved. In the case of liquids, higher fractional releases are obviously possible, but here, the multiple barriers provided by the Type A package materials, including absorbents and double containment systems, remain effective even after severe impact or crushing accidents [I.24]. For example, in an accident where an I-131 source was completely crushed, less than 2% of the package contents remained on the road after removal of the package debris [I.26].

I.32. Potentially the most severe accident environment for many Type A packages is the combination of severe mechanical damage and fire. However, even in this situation, the role of debris may be significant in retaining released radioactive material, as noted in Refs [I.23, I.24].

I.33. Frequently, fires produce relatively large sized particulate material, which would tend to minimize any intake via inhalation, while at the same time providing a significant surface area for the absorption of volatile species and particularly of vaporized liquids. A further mitigatory factor is the enhanced local dispersion associated with the convective air currents due to the fire, which would also tend to reduce intake via inhalation.

I.34. The 10⁻⁴–10⁻³ range of uptake factors now used within the Q system is based upon consideration of a range of possible accident situations, both indoors and out of doors. The

original Q system proposals considered exposure within a storeroom or cargo handling bay of 300 m³ volume with four air changes per hour. Assuming an adult breathing rate of 3.3×10^{-4} m³/s, results in an uptake factor of approximately 10^{-3} for a 30 min exposure period. An alternative accident scenario might involve exposure in a transport vehicle of 50 m³ volume, with ten air changes per hour, as originally employed in the determination of the Type B(U) or Type B(M) package normal transport leakage limit in the 1985 Edition of the Transport Regulations. Using the same breathing rate and exposure period as above, this leads to an uptake factor of 2.4×10^{-3} .

I.35. For accidents occurring outdoors, the most conservative assumption for the atmospheric dispersion of released material is that of a ground level point source. Tabulated dilution factors for this situation, at a downwind distance of 100 m, range from 7×10^{-4} to 1.7×10^{-2} s/m³ [I.27], corresponding to uptake factors in the range 2.3×10^{-7} to 5.6×10^{-6} for the adult breathing rate cited in para. I.34. These uptake values apply to short term releases and cover the range from highly unstable to highly stable weather conditions; the corresponding value for average conditions is 3.3×10^{-7} , towards the lower end of the range quoted above.

I.36. Extrapolation of the models used to evaluate the atmospheric dilution factors used here to shorter downwind distances is unreliable, but reducing the exposure distance by an order of magnitude to 10 m would increase the above uptake factors by about a factor of 30. This indicates that as the downwind distance approaches a few metres, the uptake factors would approach the 10^{-4} – 10^{-3} range used within the Q system. However, under these circumstances, other factors that would tend to reduce the uptake come into effect and may even become dominant. The additional turbulence to be expected in the presence of a fire has been mentioned earlier. Similar reductions in airborne concentrations can be anticipated as a result of turbulence originating from the flow of air around any vehicle involved in an accident or from the effects of nearby buildings.

I.37. Thus, on balance, it is considered that uptake factors in the range 10^{-4} – 10^{-3} are reasonable for the determination of Type A package contents limits. Taken in conjunction with the release fractions already discussed, the overall intake factor of 10^{-6} was used, as in the 1985 Edition of the Transport Regulations. However, within the Q system, this value represents a combination of releases, typically in the range 10^{-3} – 10^{-2} of the package contents as a respirable aerosol, combined with an uptake factor of up to 10^{-4} – 10^{-3} of the released material. Together with the limiting doses cited earlier, this leads to an expression for the contents limit based on inhalation of the form:

$$Q_C = \frac{D}{1 \times 10^{-6} DC_{inh}} \quad (I.8)$$

where

D is the reference dose of 0.05 Sv;

1×10^{-6} is the fraction of the contents of a package that is inhaled;

DC_{inh} is the dose coefficient for inhalation;

Thus, Q_C can be calculated as:

$$Q_C(\text{TBq}) = \frac{5 \times 10^{-8}}{e_{\text{inh}}} \quad (\text{I.9})$$

where e_{inh} is the effective dose coefficient for inhalation (see para. I.39) of the radionuclide (Sv/Bq). Values for e_{inh} may be found in Table III. of IAEA Safety Standards Series No. GSR Part 3, Radiation Protection and Safety of Radiation Sources: International Basic Safety Standards [I. 9].

I.38. The ranges for the release factor and the uptake factor are, in part, determined by the chemical form of the materials and the particle size of the aerosol. The chemical form has a major influence on the dose per unit intake. In calculating Q_C , the most restrictive chemical form has been assumed and the effective dose coefficients, for an aerosol characterized by an AMAD of 1 μm are assumed [I.9]. The 1 μm AMAD value used in the earlier Q system is retained, even though other AMAD values can give more conservative dose coefficients for some radionuclides.

I.39. For uranium, the Q_C values are presented in terms of the lung absorption types assigned for the major chemical forms of uranium. This, more detailed evaluation of Q_C , was undertaken because of the sensitivity of the dose per unit intake to the absorption type and the fact that the chemical form of uranium in transport is generally known.

Q_D: Skin contamination and ingestion doses

I.40. The Q_D value for beta emitters is determined by consideration of the beta dose to the skin of a person contaminated with non-special form radioactive material as a consequence of handling a damaged Type A package. The model proposed within the Q system assumes that 1% of the package contents are spread uniformly over an area of 1 m^2 ; handling of the debris is assumed to result in contamination of the hands to 10% of this level [I.28]. It is further assumed that the exposed person is not wearing gloves but would recognize the possibility of contamination and wash their hands within a period of 5 h.

I.41. Taken individually, these assumptions are somewhat arbitrary, but taken as a whole they represent a reasonable basis for estimating the level of skin contamination that might arise under accident conditions. This is $10^{-3} \times Q_D/\text{m}^2$, with a dose rate limit for the skin of 0.1 Sv/h based on a 5 h exposure period.

I.42. In the 1985 Edition of the Transport Regulations, the conversion to dose was based on the maximum energy of the beta spectra in a histogram type presentation. Values for Q_D have now been calculated using the beta spectra and discrete electron emissions for the radionuclides, as tabulated by the ICRP [I.12, I.14]. The emission data for the nuclide of interest were used with data from Ref. [I.29] on the skin dose rate for monoenergetic electrons emitted from the surface of the skin. Q_D is given by:

$$Q_D = \frac{D}{1 \times 10^{-3} \text{DRC}_{\text{skin}} \times t} \quad (\text{I.10})$$

where

D is the reference dose of 0.5 Sv;

1×10^{-3} is the fraction of the package content distributed per unit area of the skin (m^{-2});

DRC_{skin} is the equivalent skin dose rate coefficient for skin contamination;

t is the exposure time of 1.8×10^4 s (5 h);

I.43. Thus, Q_D can be determined from:

$$Q_D(\text{TBq}) = \frac{2.8 \times 10^{-2}}{\dot{h}_{\text{skin}}} \quad (\text{I.11})$$

where \dot{h}_{skin} is the equivalent skin dose rate per unit activity per unit area of the skin ($\text{Sv} \cdot \text{s}^{-1} \cdot \text{TBq}^{-1} \cdot \text{m}^2$). Dose and dose rate coefficients may be found in Table II.2 of Appendix II.

I.44. For a number of radionuclides, the Q_D values are more restrictive than those of the earlier Q system. These lower Q_D values are primarily associated with radionuclides that emit internal conversion electrons.

I.45. The models used in deriving the Q_D values based on skin dose may also be employed to estimate the possible uptake of radioactive material via ingestion. Assuming that a person may ingest all the contamination from 10^{-3} m^2 (10 cm^2) of skin over a 24 h period [I.28], the resultant intake is $10^{-6} \times Q_D$, compared with that via inhalation of $10^{-6} \times Q_C$ derived earlier. Since the dose per unit intake via inhalation is generally of the same order as, or greater than, that via ingestion [I.9], the inhalation pathway will normally be limiting for internal contamination and, therefore, explicit consideration of the ingestion pathway is unnecessary.

Q_E: Submersion dose due to gaseous isotopes

I.46. The Q_E value for gaseous isotopes that do not become incorporated into the body is determined by consideration of the submersion dose following their release in an accident when transported as non-special form radioactive material in either a compressed or an uncompressed state. A rapid 100% release of the package contents into a storeroom or cargo handling bay of dimensions $3 \text{ m} \times 10 \text{ m} \times 10 \text{ m}$ with four air changes per hour is assumed. This leads to an initial airborne concentration of $Q_E / 300 \text{ m}^3$, which falls exponentially with a decay constant of 4 h^{-1} as a result of ventilation over the subsequent 30 min exposure period to give a mean concentration level of $1.44 \times 10^{-3} \times Q_E$ (m^{-3}). From this, doses are calculated using an effective dose coefficient or an equivalent skin dose coefficient for submersion in a semi-infinite cloud, from Ref. [I.30], as shown in Table I.1.

TABLE I.1. DOSE COEFFICIENTS FOR SUBMERSION

Dose coefficients h_{sub} for submersion ($\text{Sv}\cdot\text{Bq}^{-1}\cdot\text{s}^{-1}\cdot\text{m}^3$)					
Nuclide	$h_{\text{E,subm}}$ (effective dose)	$H_{\text{skin,subm}}$ (equivalent skin dose)	Nuclide	$h_{\text{E,subm}}$ (effective dose)	$H_{\text{skin,subm}}$ (equivalent skin dose)
Ar-37	0	0	Xe-122	2.19×10^{-15}	3.36×10^{-15}
Ar-39	1.15×10^{-16}	1.07×10^{-14}	Xe-123	2.82×10^{-14}	4.52×10^{-14}
Ar-41	6.14×10^{-14}	1.01×10^{-13}	Xe-127	1.12×10^{-14}	1.57×10^{-14}
Ar-42	No value	No value	Xe-131m	3.49×10^{-16}	4.82×10^{-15}
Kr-81	2.44×10^{-16}	4.04×10^{-16}	Xe-133	1.33×10^{-15}	4.97×10^{-15}
Kr-85	2.40×10^{-16}	1.32×10^{-14}	Xe-135	1.10×10^{-14}	3.12×10^{-14}
Kr-85m	6.87×10^{-15}	2.24×10^{-14}	Rn-218	3.40×10^{-17}	4.30×10^{-17}
Kr-87	3.97×10^{-14}	1.37×10^{-13}	Rn-219	2.46×10^{-15}	3.38×10^{-15}
			Rn-220	1.72×10^{-17}	2.20×10^{-17}
			Rn-222	1.77×10^{-17}	2.28×10^{-17}

I.47. The Q_E value is the lesser of two values calculated using an effective dose coefficient and an equivalent skin dose coefficient. Q_E is given by:

$$Q_E = \frac{D}{d_f \times \text{DRC}_{\text{subm}}} \quad (\text{I.12})$$

where

D is the reference dose of 0.05 Sv for the effective dose or 0.5 Sv for the equivalent dose to the skin;

d_f is the time integrated air concentration;

DRC_{subm} is the effective dose coefficient or the equivalent skin dose coefficient for submersion in $\text{Sv}\cdot\text{Bq}^{-1}\cdot\text{s}^{-1}\cdot\text{m}^3$;

In this equation, the value for d_f was set to $2.6 \text{ Bq} \cdot \text{s} \cdot \text{m}^{-3}$ per Bq released for the defined room.

I.48. Thus, Q_E can be calculated from the following.

For the effective dose:

$$Q_E(\text{TBq}) = \frac{1.9 \times 10^{-14}}{h_{E,\text{subm}}} \quad (\text{I.13})$$

where $h_{E,\text{subm}}$ is the effective dose coefficient for submersion in $\text{Sv} \cdot \text{Bq}^{-1} \cdot \text{s}^{-1} \cdot \text{m}^3$.

For the equivalent dose to the skin:

$$Q_E(\text{TBq}) = \frac{1.9 \times 10^{-13}}{h_{\text{skin},\text{subm}}} \quad (\text{I.14})$$

where $h_{\text{skin},\text{subm}}$ is the equivalent skin dose coefficient for submersion in $\text{Sv} \cdot \text{Bq}^{-1} \cdot \text{s}^{-1} \cdot \text{m}^3$.

SPECIAL CONSIDERATIONS

I.49. The dosimetric models described in paras. I.8–I.47 apply to the vast majority of radionuclides of interest and may be used to determine their Q values and associated A_1 and A_2 values. However, in a limited number of cases, the models are inappropriate or require modification. The special considerations applying in such circumstances are discussed in this section.

Consideration of parent and progeny radionuclides

I.50. The earlier Q system assumed a maximum transport time of 50 d, and thus radioactive decay products with half-lives of less than 10 d were assumed to be in equilibrium with their longer lived parents. In such cases, the Q values were calculated for the parent and its progeny, and the limiting value was used in determining the A_1 and A_2 values of the parent. In cases where a progeny radionuclide has a half-life either greater than 10 d or greater than that of the parent nuclide, such progeny, with the parent, were considered to be a mixture.

I.51. The 10 d half-life criterion is retained. Progeny radionuclides with half-lives of less than 10 d are assumed to be in secular equilibrium with the longer lived parent; however, the progeny's contribution to each Q value is summed with that of the parent. This provides a means of accounting for progeny with branching fractions of less than unity; for example, Ba-137m is produced in 94.6% of the decays of its parent Cs-137. If the parent's half-life is less than 10 d and the progeny's half-life is greater than 10 d, then the mixture rule is to be used by the consignor. For example, a package containing Ca-47 (4.53 d) has been evaluated with its Sc-47 (3.351 d) progeny in transient equilibrium with the parent. A package containing Ge-77 (11.3 h) will be evaluated by the consignor as a mixture of Ge-77 and its progeny, As-77 (38.8 h).

I.52. In some cases, a long lived progeny is produced by the decay of a short lived parent. In these cases, the potential contribution of the progeny to the exposure cannot be assessed without knowledge of the transport time and the buildup of progeny nuclides. It is necessary

to determine the transport time and the buildup of progeny nuclides for the package and establish the A_1/A_2 values using the mixture rule. As an example, consider Te-131m (30 h), which decays to Te-131 (25 min), which, in turn, decays to I-131 (8.04 d). The mixture rule should be applied by the consignor to this package with the I-131 activity derived on the basis of the transport time and the buildup of progeny nuclides.

Alpha emitters

I.53. For alpha emitters, it is not, in general, appropriate to calculate Q_A or Q_B values for special form material, owing to their relatively weak gamma and beta emissions. In the 1973 Edition of the Transport Regulations, an arbitrary upper limit for special form alpha sources of $10^3 A_2$ was introduced. There is no dosimetric justification for this procedure: in recognition of this, coupled with the good record in the transport of special form radioactive material and the reduction in many Q_C values for alpha emitters resulting from the use of the ICRP recommendations [I.8], a tenfold increase in this factor was introduced. Thus, an additional Q value, $Q_F = 10^4 \times Q_C$, is defined for special form alpha emitters and is listed in the column headed Q_A , where appropriate, in the tabulation of Q values.

I.54. A radionuclide is defined as an alpha emitter if, in greater than 0.1% of its decays, it emits alpha particles or it decays to an alpha emitter. For example, Np-235, which decays by alpha emission in 1.4×10^{-5} of its decays, is not an alpha emitter for the purpose of the special form consideration. Pb-212, however, is an alpha emitter since its daughter Bi-212 undergoes alpha decay. Overall, the special form limits for alpha emitters have increased with increases in Q_C .

I.55. With respect to the ingestion of alpha emitters, arguments analogous to those used for beta emitters in the discussion on Q_D apply and the inhalation pathway, rather than the ingestion pathway, is always more restrictive; hence, the latter is not explicitly considered.

Neutron emitters

I.56. In the case of neutron emitters, it was originally suggested under the Q system that there were no known situations with (α, n) or (γ, n) sources or the spontaneous neutron emitter Cf-252 for which neutron dose would contribute significantly to the external or internal radiation pathways considered earlier [I.4]. However, neutron dose cannot be neglected in the case of Cf-252 sources. Data given in ICRP Publication 21 [I.31] for neutron and gamma emissions indicate a dose rate of 25.4 Sv/h at 1 m from a 1 g Cf-252 source: this produces a Q_A value for Cf-252 of 0.095 TBq. The increase of a factor of about 2 in the radiation weighting factor for neutrons recommended by the ICRP [I.8] gives a value of 4.7×10^{-2} TBq for Q_A , which was used to determine the value of A_1 in the 1996 Edition of the Transport Regulations. This is more restrictive than the Q_F value of 28 TBq obtained on the basis of the revised expression for special form alpha emitters. The neutron radiation from Cf-252 source dominates the external dose: a similar considerations apply to the two other potential spontaneous fission sources, Cm-248 and Cf-254. The Q_A values for these radionuclides were evaluated by assuming the same dose rate conversion factor per unit activity as that for the Cf-252 source quoted above, with allowance for their respective neutron emission rates relative to that of this source. The A_1 value for Cf-252 was updated as described in Ref. [I.32] in accordance with recommendations of the ICRP [I.33], and this revised value was used in the 1996 (As Amended) Edition and all subsequent editions of the Transport Regulations.

Bremsstrahlung

I.57. The A_1 and A_2 values tabulated in the 1973 Edition of the Transport Regulations were subject to an upper cut-off limit of 1000 Ci, to protect against the possible effects of bremsstrahlung. Within the Q system, this cut-off was retained at 40 TBq. It was recognized as an arbitrary cut-off and is not specifically associated with bremsstrahlung radiation or any other dosimetric consideration.

I.58. A preliminary evaluation of bremsstrahlung, in a manner consistent with the assumptions of Q_A and Q_B , indicates that the 40 TBq figure is a reasonable value. However, explicit inclusion of bremsstrahlung within the Q system might limit A_1 and A_2 for some nuclides to about 20 TBq, a factor of 2 lower. Overall, this evaluation supports the continued use of a 40 TBq cut-off.

Tritium and its compounds

I.59. During the development of the Q system, it was considered that liquids containing tritium should be considered separately. The scenario considered was the spillage of a large quantity of tritiated water in a confined area followed by a fire. As a result, the A_2 value for tritiated liquids was set at 40 TBq in the 1985 Edition of the Transport Regulations, with an additional condition that the concentration should be lower than 1 TBq/L. These values have been retained.

Radon and its progeny

I.60. As noted in para. I.51, the derivation of Q_E applies to radionuclides that are in the form of noble gases that are not incorporated into the body. As such, it only applies to radionuclides whose progeny are either a stable nuclide or another noble gas. In a few cases this condition is not fulfilled and dosimetric routes other than external exposure due to submersion in a radioactive cloud should be considered [I.34]. Within the context of the Transport Regulations, the only case of practical importance is that of Rn-222.

I.61. The corresponding Q_C value in the 1985 Edition of the Transport Regulations was calculated to be 3.6 TBq. However, allowing for a 100% release of radon, rather than the 10^{-3} – 10^{-2} aerosol release fraction incorporated in the Q_C model, this reduces to a Q_C value in the range 3.6×10^{-3} to 3.6×10^{-2} TBq. Furthermore, treating Rn-222 and its progeny as a noble gas resulted in a Q_E value of 4.2×10^{-3} TBq; towards the lower end of the range of Q_C values, and this is still the Type A package non-special form limit cited for Rn-222 in the tabulation of Q values.

APPLICATIONS

Low specific activity material with ‘unlimited’ A_1 or A_2 values

I.62. The 1973 Edition of the Transport Regulations recognized a category of materials whose specific activities are so low that it is inconceivable that an intake could occur that would give rise to a significant radiation hazard, namely, LSA materials. These materials were defined in terms of a model where it was assumed that it is most unlikely that a person would remain in a dusty atmosphere long enough to inhale more than 10 mg of material. Under these conditions, if the specific activity of the material is such that the mass intake is equivalent to or less than the activity intake assumed to occur for a person involved in an accident with a Type A package, namely $10^{-6}A_2$, then this material should not present a greater hazard during

transport than the quantities of radioactive material transported in Type A packages. This hypothetical model is retained within the Q system and leads to an LSA criterion limit of $10^{-4} \times Q_C/g$. Thus, the Q values for those radionuclides whose specific activity is below this level are listed as 'unlimited'. In the cases where this criterion is satisfied, the effective dose associated with an intake of 10 mg of the nuclide is less than the dose criterion of 50 mSv. Natural uranium and thorium, depleted uranium and other materials such as U-238, Th-232 and U-235 satisfy the above LSA criterion. Calculations using the dose coefficients listed in GSR Part 3 [I.29] indicate that unirradiated uranium enriched to <20% also satisfies the same criterion, on the basis of the isotopic mixtures given in ASTM C996-90 [I.35]. The A_1 and A_2 values for irradiated reprocessed uranium should be calculated on the basis of the mixtures equation used in paragraph 405 of the Transport Regulations, taking into account uranium radionuclides and fission products.

I.63. A further consideration relevant to LSA material in the context of the skin contamination model used in the derivation of Q_D is the mass of material that might be retained on the skin for any significant period of time. It is considered that, typically, 1–10 mg/cm² of dirt present on the hands would be readily discernible and would be removed promptly by wiping or washing, irrespective of the possible activity. It was agreed that the upper end of this range was an appropriate limit for the mass of material retained on the skin: in combination with the skin contamination model for Q_D , this results in an LSA limit of $10^{-5} \times Q_D/g$. On this basis, Q_D values for radionuclides for which this criterion applies are also listed as unlimited in the tabulation of Q values.

Release rates for normal transport

I.64. In the 1973 Edition of the Transport Regulations, in determining the maximum allowable release rate for Type B(U) or Type B(M) packages under the conditions of normal transport, the most adverse expected condition was judged to be a worker spending 20% of his or her working time in an enclosed vehicle of 50 m³ volume, with ten air changes per hour. The vehicle was considered to contain a Type B(U) or Type B(M) package leaking activity at a rate of r (Bq/h) and it was assumed, conservatively, that the resulting airborne activity concentration was in equilibrium at all times. On this basis the annual activity intake via inhalation, I_a , for a person working 2000 h per year with an average breathing rate of 1.25 m³/h was evaluated as:

$$I_a = \frac{r}{50 \times 10} \times 1.25 \times 2000 \times 0.2 \quad (\text{I.15})$$

which is equivalent to:

$$I_a = r$$

I.65. Thus, the maximum activity of intake over one year is equal to the activity released in 1 h.

I.66. This assumes that all the released material becomes airborne and is available for inhalation, which may be a gross overestimate for many materials. Also, equilibrium conditions are assumed to prevail at all times. These factors, together with the principle that leakage from Type B(U) or Type B(M) packages should be minimized, indicated that the exposure of transport workers would only be a small fraction of the dose limits for radiation

workers at that time [I.5]. In addition, this level of conservatism was considered adequate to cover the unlikely situation of several leaking packages contained in the same vehicle.

I.67. In the 1985 Edition of the Transport Regulations, the maximum allowable release rates for Type B(U) or Type B(M) packages under normal transport conditions were unchanged, although some of the parameters used in the above derivation were updated, and the annual dose limits and annual intake limits recommended by the ICRP at that time [I.18] were taken into account. These, in turn, were incorporated into the improved method, known as the Q system, for evaluating the Type A package contents limit A_1 and A_2 values.

I.68. The earlier models assume an extremely pessimistic exposure time of 2000 h per year. Retaining this value, together with exposure within a room of $30\text{ m} \times 10\text{ m} \times 10\text{ m}$ (3000 m^3) with four air changes per hour, and an adult breathing rate of $1.25\text{ m}^3/\text{h}$, the permitted release rate, r , for an effective dose of 20 mSv can be calculated as follows:

$$r = \frac{20 \times 10^{-6} A_2}{50} \times \frac{3000 \times 4}{2000 \times 1.25} \quad (\text{I.16})$$

$$r = 1.9 \times 10^6 A_2 \quad (\text{I.17})$$

I.69. The room size assumed is larger than that assumed for an acute release under the Q system. However, the assumed exposure time is very pessimistic. Exposure for 200 hours in a much more confined space of 300 m^3 would lead to the same predicted effective dose. For exposure out of doors for persons in the vicinity of a leaking Type B(U) or Type B(M) package, the maximum inhalation dose would be very much lower.

I.70. The current limit of $10^{-6} A_2$ per hour is thus retained and is shown to be conservative. Experience shows that it is rare for packages in routine transport to leak at rates near the permitted limit. Indeed, such leakage for packages carrying liquids would lead to very severe surface contamination in the vicinity of the seals and would be obvious as a result of any radiological surveys during transit or on receipt by the consignee.

Release rates for accident conditions

I.71. Accidents of the severity simulated in the Type B tests specified in the Transport Regulations are unlikely to occur in a confined space indoors, or if they did, the resulting conditions would be such as to necessitate immediate evacuation of all persons in the vicinity [I.2]. Hence, the exposure scenario of interest in this context is that of an accident occurring out of doors. In this situation, the radiological implications of the maximum allowable release of A_2 over a period of one week from a Type B(U) or Type B(M) package may be expressed as an equivalent dose limit by consideration of the exposure to a person remaining continuously downwind of the damaged package throughout the period of the release [I.36].

I.72. In practice, it is unlikely that any accidental release would persist for the full period of one week. In most situations, emergency workers would attend the scene of an accident and take effective remedial action to limit the release within a period of a few hours. On this basis, the maximum effective dose via inhalation to persons exposed in the range 50–200 m downwind from a damaged Type B(U) or Type B(M) package under average weather

conditions is 1–10 mSv, increasing by a factor of about 5 under generally less probable and persistent stable meteorological conditions (see, for example, Fig. 3 of Ref. [I.37]). Local containment and atmospheric turbulence effects close to the radioactive source, plus possible plume rise effects if a fire were involved, will tend to minimize the doses beyond a few tens of metres from the source towards the lower end of the dose ranges cited above. The neglect of potential doses to persons within a few tens of metres of the source is considered justified in part by the conservative assumption of continuous exposure downwind of the source throughout the release period, and in part by the fact that emergency services personnel in this area should be working under health physics supervision and control.

Special provision for Kr-85

I.73. The special provision in the case of Kr-85, was introduced in the 1973 Edition of the Transport Regulations and was retained in the 1985 Edition of the Transport Regulations, and is based on a consideration of the dosimetric consequences of a release of this radionuclide. The allowable release of $10A_2$ was originally derived on the basis of a comparison of the potential radiation dose to the whole body, or to any critical organ, of persons exposed within 20 m of a source of Kr-85 and any other radionuclides' (both gaseous or non-gaseous). It was noted that the inhalation pathway model used in the derivation of A_2 values at the time was inappropriate for a noble gas, i.e. which is not significantly incorporated into body tissues. In the 1996 Edition of the Transport Regulations, under the Q system, the A_2 value for Kr-85 was made equal to the Q_E value based on the submersion dose to the skin of persons exposed indoors following the rapid release of the contents of a Type A package in an accident. For a release of A_2 that is subject to a dilution factor, df , the maximum effective dose via inhalation, D_{inh} , is given by:

$$D_{inh} = A_2 \times df \times 3.3 \times 10^{-4} \times \frac{50}{A_2 \times 10^{-6}} \quad (\text{I.18})$$

where 3.3×10^{-4} is the average adult breathing rate in m^3/s and an intake of $10^{-6}A_2$ has been equated with a dose of 50 mSv. On the same basis, a release of $10A_2$ for Kr-85 (100 TBq) results in a submersion dose given by:

$$D_{subm} = 100 \times df \times 2.4 \times 10^{-1} \quad (\text{I.19})$$

where 2.4×10^{-1} is the submersion dose coefficient in $\text{mSv} \cdot \text{m}^3 \cdot \text{TBq}^{-1} \cdot \text{s}^{-1}$.

From the above expressions, D_{inh}/D_{subm} is about 700. Thus, the Type B(U) or Type B(M) package activity release limit for Kr-85 is seen to be conservative by more than two orders of magnitude in comparison with other non-gaseous radionuclides.

I.74. In 2009, a group of experts reviewed the validity of the factor of 10 for Kr-85 activity release rates compared with other radionuclides. With regard to normal conditions of transport, the following scenario was developed for submersion in Kr-85 released from a type B(U) or type B(M) package.

(a) The same environment parameters as in para. I.76 are considered, as follows:

- A room volume of 300 m³;
- An air change rate of 4 h⁻¹;
- An exposure time of 200 h
- A skin submersion dose coefficient of $1.32 \times 10^{-14} \text{ Sv}\cdot\text{s}^{-1}/(\text{Bq}\cdot\text{m}^{-3})$ [I.30].

(b) With a uniform release rate (RR in Bq/h), the mean Kr-85 concentration is:

$$\text{concentration (Bq/m}^3) = \text{RR}/(300 \times 4) = 8.3 \times 10^{-4} \times \text{RR} \quad (\text{I.20})$$

(c) and the skin dose from an exposure time of 200 h is:

$$\begin{aligned} D (\text{Sv}) &= \text{concentration (Bq/m}^3) \times \text{equivalent skin dose coefficient (Sv}\cdot\text{m}^3/(\text{Bq}\cdot\text{s})) \\ &\quad \times \text{exposure (s)} \end{aligned} \quad (\text{I.21})$$

$$= 8.33 \times 10^{-4} \times \text{RR} \times 1.32 \times 10^{-14} \times 200 \times 3600 = 7.92 \times 10^{-12} \times \text{RR}$$

(d) So as not to exceed the annual equivalent skin dose limit of 0.05 Sv for the public, the RR should be limited to:

$$\begin{aligned} \text{RR (Bq/h)} &= 0.05 / (7.92 \times 10^{-12}) \\ &= 6.3 \times 10^9 \text{ Bq/h} = 6.3 \times 10^{-4} \text{A}_2/\text{h} \end{aligned}$$

(e) This value is 63 times greater than the current regulatory criterion of $10 \times 10^{-6} \text{A}_2/\text{h}$ for Kr-85, which is therefore conservative.

With regard to the accident conditions of transport, the following scenario was developed for submersion by Kr-85 activity released from a type B package:

(a) The same parameters as those in para. I.79 are considered, i.e.:

- A distance to the package of 100 m;
- A dilution factor of $8 \times 10^{-3} \text{ s/m}^3$;
- An equivalent skin dose coefficient of $1.32 \times 10^{-14} \text{ Sv}\cdot\text{m}^3/(\text{Bq}\cdot\text{s})$;
- An instantaneous release of 10A_2 (10^{14} Bq).

(b) The equivalent skin dose is:

$$D (\text{Sv}) = \text{activity (Bq)} \times \text{dilution factor (s/m}^3) \times \text{equivalent skin dose coefficient (Sv}\cdot\text{m}^3/(\text{Bq}\cdot\text{s})) \quad (\text{I.22})$$

$$= 10^{14} \times 8 \times 10^{-3} \times 1.32 \times 10^{-14}$$

$$= 10.6 \text{ mSv.}$$

- (c) This value is below the criteria for equivalent dose or committed equivalent dose received by individual organs in accident conditions, as stated in para. I.9(b), and below the annual equivalent skin dose limit of 500 mSv.
- (d) A distance to the package of 15 m has also been considered; this distance implies a dilution factor of 17 times less than that at 100m. Consequently, the equivalent skin dose becomes 180 mSv. This value is still below the equivalent skin dose limit of 500 mSv for individual organs in accident conditions.
- (e) It is then concluded that the current regulatory criterion of $10A_2/\text{week}$ would not lead to exceeding the skin dose limit.

TABULATION OF Q VALUES

I.75. A full listing of Q values determined on the basis of the models described in this appendix is given in Table I.2. Also included are the corresponding Type A package A_1 and A_2 contents limit values for special form and non-special form radioactive material, respectively. The Q values shown in Table I.2 have been rounded to two significant figures and the A_1 and A_2 values to one significant figure; in the latter case, the arbitrary 40 TBq cut-off has also been applied.

I.76. In general, the new values lie within a factor of about 3 of the earlier values; there are a few radionuclides where the new A_1 and A_2 values are outside this range. A few tens of radionuclides have new A_1 values higher than previous values by factors ranging between 10 and 100. This is mainly due to the improved modelling for beta emitters. There are no new A_1 or A_2 values lower than the previous figures by more than a factor of 10. A few radionuclides previously listed are now excluded, but additional isomers are included, namely, both isomers of Eu-150 and Np-236.

Consideration of physical and chemical properties

I.77. A further factor is whether there is a need to apply additional limits for materials whose physical properties might render the assumptions made in deriving the Q values invalid. Such considerations are relevant to materials that might become volatile at the elevated temperatures that could occur in a fire, or that are transported as very fine powders, especially for the model used to evaluate the Q_C values. However, on balance, it is considered that only in the most extreme circumstances would the assumed intake factor of 10^{-6} be exceeded and that special modification of the Q_C model was unnecessary for these materials.

I.78. As in the case of the 1985 Edition of the Transport Regulations, no consideration is given to the chemical form or chemical properties of radionuclides. However, in the determination of Q_C values, the most restrictive of the dose coefficients recommended by the GSR Part 3 [9] were used.

TABLE I.2. TYPE A PACKAGE CONTENTS LIMITS: Q_A - Q_F , A_1 and A_2 .

Radionuclide	a – Q _F tabulated in place of Q _A	Q _A or Q _F (TBq)	Q _B (TBq)	Q _C (TBq)	Q _D or Q _E (TBq)	A ₁ (TBq)	A ₂ (TBq)
Ac-225		$4.9 \times 10^{+00}$	8.5×10^{-01}	6.3×10^{-03}	3.0×10^{-01}	8×10^{-01}	6×10^{-03}
Ac-227	a	9.3×10^{-01}	$1.3 \times 10^{+02}$	9.3×10^{-05}	$3.7 \times 10^{+01}$	9×10^{-01}	9×10^{-05}
Ac-228		$1.2 \times 10^{+00}$	5.6×10^{-01}	$2.0 \times 10^{+00}$	5.2×10^{-01}	6×10^{-01}	5×10^{-01}
Ag-105		$2.0 \times 10^{+00}$	$1.0 \times 10^{+03}$	$6.3 \times 10^{+01}$	$2.5 \times 10^{+01}$	$2 \times 10^{+00}$	$2 \times 10^{+00}$
Ag-108m		6.5×10^{-01}	$5.9 \times 10^{+00}$	$1.4 \times 10^{+00}$	$6.0 \times 10^{+00}$	7×10^{-01}	7×10^{-01}
Ag-110m		4.2×10^{-01}	$1.9 \times 10^{+01}$	$4.2 \times 10^{+00}$	$2.1 \times 10^{+00}$	4×10^{-01}	4×10^{-01}
Ag-111		$4.1 \times 10^{+01}$	$1.9 \times 10^{+00}$	$2.9 \times 10^{+01}$	6.2×10^{-01}	$2 \times 10^{+00}$	6×10^{-01}
Al-26		4.3×10^{-01}	1.4×10^{-01}	$2.8 \times 10^{+00}$	7.1×10^{-01}	1×10^{-01}	1×10^{-01}
Am-241	a	$1.3 \times 10^{+01}$	$1.0 \times 10^{+03}$	1.3×10^{-03}	$3.8 \times 10^{+02}$	$1 \times 10^{+01}$	1×10^{-03}
Am-242m	a	$1.4 \times 10^{+01}$	$5.0 \times 10^{+01}$	1.4×10^{-03}	8.4×10^{-01}	$1 \times 10^{+01}$	1×10^{-03}
Am-243		$5.0 \times 10^{+00}$	$2.6 \times 10^{+02}$	1.3×10^{-03}	4.1×10^{-01}	$5 \times 10^{+00}$	1×10^{-03}
Ar-37		$1.0 \times 10^{+03}$	$1.0 \times 10^{+03}$	—	$1.0 \times 10^{+03}$	$4 \times 10^{+01}$	$4 \times 10^{+01}$
Ar-39		—	$7.3 \times 10^{+01}$	—	$1.8 \times 10^{+01}$	$4 \times 10^{+01}$	$2 \times 10^{+01}$
Ar-41		8.8×10^{-01}	3.1×10^{-01}	—	3.1×10^{-01}	3×10^{-01}	3×10^{-01}
As-72		6.1×10^{-01}	2.8×10^{-01}	$5.4 \times 10^{+01}$	6.5×10^{-01}	3×10^{-01}	3×10^{-01}
As-73		$9.5 \times 10^{+01}$	$1.0 \times 10^{+03}$	$5.4 \times 10^{+01}$	$1.0 \times 10^{+03}$	$4 \times 10^{+01}$	$4 \times 10^{+01}$
As-74		$1.4 \times 10^{+00}$	$1.7 \times 10^{+00}$	$2.4 \times 10^{+01}$	9.4×10^{-01}	$1 \times 10^{+00}$	9×10^{-01}
As-76		$2.5 \times 10^{+00}$	2.5×10^{-01}	$6.8 \times 10^{+01}$	5.9×10^{-01}	3×10^{-01}	3×10^{-01}
As-77		$1.3 \times 10^{+02}$	$1.8 \times 10^{+01}$	$1.3 \times 10^{+02}$	6.5×10^{-01}	$2 \times 10^{+01}$	7×10^{-01}
At-211		$2.5 \times 10^{+01}$	$1.0 \times 10^{+03}$	5.1×10^{-01}	$4.4 \times 10^{+02}$	$2 \times 10^{+01}$	5×10^{-01}
Au-193		$7.0 \times 10^{+00}$	$1.0 \times 10^{+03}$	$4.2 \times 10^{+02}$	$1.8 \times 10^{+00}$	$7 \times 10^{+00}$	$2 \times 10^{+00}$
Au-194		$1.1 \times 10^{+00}$	$1.0 \times 10^{+03}$	$2.0 \times 10^{+02}$	$6.1 \times 10^{+00}$	$1 \times 10^{+00}$	$1 \times 10^{+00}$

Radionuclide	a – Q _F tabulated in place of Q _A	Q _A or Q _F (TBq)	Q _B (TBq)	Q _C (TBq)	Q _D or Q _E (TBq)	A ₁ (TBq)	A ₂ (TBq)
Au-195		$1.3 \times 10^{+01}$	$1.0 \times 10^{+03}$	$3.1 \times 10^{+01}$	$5.5 \times 10^{+00}$	$1 \times 10^{+01}$	$6 \times 10^{+00}$
Au-198		$2.6 \times 10^{+00}$	$1.1 \times 10^{+00}$	$6.0 \times 10^{+01}$	6.1×10^{-01}	$1 \times 10^{+00}$	6×10^{-01}
Au-199		$1.4 \times 10^{+01}$	$1.0 \times 10^{+03}$	$6.7 \times 10^{+01}$	6.4×10^{-01}	$1 \times 10^{+01}$	6×10^{-01}
Ba-131		$1.6 \times 10^{+00}$	$1.0 \times 10^{+03}$	$1.9 \times 10^{+02}$	$2.2 \times 10^{+00}$	$2 \times 10^{+00}$	$2 \times 10^{+00}$
Ba-133		$2.6 \times 10^{+00}$	$1.0 \times 10^{+03}$	$3.3 \times 10^{+01}$	$1.0 \times 10^{+01}$	$3 \times 10^{+00}$	$3 \times 10^{+00}$
Ba-133m		$1.5 \times 10^{+01}$	$1.0 \times 10^{+03}$	$2.6 \times 10^{+02}$	6.2×10^{-01}	$2 \times 10^{+01}$	6×10^{-01}
Ba-135m		$1.6 \times 10^{+01}$	$1.0 \times 10^{+03}$	$3.3 \times 10^{+02}$	5.9×10^{-01}	$2 \times 10^{+01}$	6×10^{-01}
Ba-140		6.3×10^{-01}	4.5×10^{-01}	$2.4 \times 10^{+01}$	3.1×10^{-01}	5×10^{-01}	3×10^{-01}
Be-7		$2.1 \times 10^{+01}$	$1.0 \times 10^{+03}$	$9.4 \times 10^{+02}$	$1.0 \times 10^{+03}$	$2 \times 10^{+01}$	$2 \times 10^{+01}$
Be-10		—	$5.8 \times 10^{+01}$	$1.5 \times 10^{+00}$	5.8×10^{-01}	$4 \times 10^{+01}$	6×10^{-01}
Bi-205		6.9×10^{-01}	$1.0 \times 10^{+03}$	$5.4 \times 10^{+01}$	$1.1 \times 10^{+01}$	7×10^{-01}	7×10^{-01}
Bi-206		3.4×10^{-01}	$1.0 \times 10^{+03}$	$2.9 \times 10^{+01}$	$1.1 \times 10^{+00}$	3×10^{-01}	3×10^{-01}
Bi-207		7.1×10^{-01}	$1.0 \times 10^{+03}$	$9.4 \times 10^{+00}$	$5.0 \times 10^{+00}$	7×10^{-01}	7×10^{-01}
Bi-210		—	$1.3 \times 10^{+00}$	6.0×10^{-01}	6.2×10^{-01}	$1 \times 10^{+00}$	6×10^{-01}
Bi-210m		$4.3 \times 10^{+00}$	6.2×10^{-01}	1.6×10^{-02}	4.9×10^{-01}	6×10^{-01}	2×10^{-02}
Bi-212		$1.0 \times 10^{+00}$	6.5×10^{-01}	$1.7 \times 10^{+00}$	5.8×10^{-01}	7×10^{-01}	6×10^{-01}
Bk-247	a	$7.7 \times 10^{+00}$	$1.0 \times 10^{+03}$	7.7×10^{-04}	$1.4 \times 10^{+00}$	$8 \times 10^{+00}$	8×10^{-04}
Bk-249		$1.0 \times 10^{+03}$	$1.0 \times 10^{+03}$	3.3×10^{-01}	$1.2 \times 10^{+01}$	$4 \times 10^{+01}$	3×10^{-01}
Br-76		4.4×10^{-01}	6.3×10^{-01}	$1.2 \times 10^{+02}$	9.9×10^{-01}	4×10^{-01}	4×10^{-01}
Br-77		$3.4 \times 10^{+00}$	$1.0 \times 10^{+03}$	$5.7 \times 10^{+02}$	$2.3 \times 10^{+01}$	$3 \times 10^{+00}$	$3 \times 10^{+00}$
Br-82		4.1×10^{-01}	$1.0 \times 10^{+03}$	$7.8 \times 10^{+01}$	7.7×10^{-01}	4×10^{-01}	4×10^{-01}
C-11		$1.0 \times 10^{+00}$	$2.0 \times 10^{+00}$	$1.0 \times 10^{+03}$	5.8×10^{-01}	$1 \times 10^{+00}$	6×10^{-01}
C-14		—	$1.0 \times 10^{+03}$	$8.6 \times 10^{+01}$	$3.2 \times 10^{+00}$	$4 \times 10^{+01}$	$3 \times 10^{+00}$

Radionuclide	a – Q _F tabulated in place of Q _A	Q _A or Q _F (TBq)	Q _B (TBq)	Q _C (TBq)	Q _D or Q _E (TBq)	A ₁ (TBq)	A ₂ (TBq)
Ca-41		$1.0 \times 10^{+03}$	$1.0 \times 10^{+03}$	Unlimited	Unlimited	Unlimited	Unlimited
Ca-45		$1.0 \times 10^{+03}$	$1.0 \times 10^{+03}$	$1.9 \times 10^{+01}$	$1.2 \times 10^{+00}$	$4 \times 10^{+01}$	$1 \times 10^{+00}$
Ca-47		$2.7 \times 10^{+00}$	$3.7 \times 10^{+01}$	$2.0 \times 10^{+01}$	3.3×10^{-01}	$3 \times 10^{+00}$	3×10^{-01}
Cd-109		$2.9 \times 10^{+01}$	$1.0 \times 10^{+03}$	$6.2 \times 10^{+00}$	$1.9 \times 10^{+00}$	$3 \times 10^{+01}$	$2 \times 10^{+00}$
Cd-113m		—	$9.1 \times 10^{+01}$	4.5×10^{-01}	6.9×10^{-01}	$4 \times 10^{+01}$	5×10^{-01}
Cd-115		$3.9 \times 10^{+00}$	$3.3 \times 10^{+00}$	$4.3 \times 10^{+01}$	3.9×10^{-01}	$3 \times 10^{+00}$	4×10^{-01}
Cd-115m		$5.0 \times 10^{+01}$	5.2×10^{-01}	$6.8 \times 10^{+00}$	6.1×10^{-01}	5×10^{-01}	5×10^{-01}
Ce-139		$6.8 \times 10^{+00}$	$1.0 \times 10^{+03}$	$2.8 \times 10^{+01}$	$2.2 \times 10^{+00}$	$7 \times 10^{+00}$	$2 \times 10^{+00}$
Ce-141		$1.6 \times 10^{+01}$	$3.2 \times 10^{+02}$	$1.4 \times 10^{+01}$	5.8×10^{-01}	$2 \times 10^{+01}$	6×10^{-01}
Ce-143		$3.7 \times 10^{+00}$	8.9×10^{-01}	$6.2 \times 10^{+01}$	6.0×10^{-01}	9×10^{-01}	6×10^{-01}
Ce-144		$2.2 \times 10^{+01}$	2.5×10^{-01}	$1.0 \times 10^{+00}$	3.8×10^{-01}	2×10^{-01}	2×10^{-01}
Cf-248	a	$6.1 \times 10^{+01}$	$1.0 \times 10^{+03}$	6.1×10^{-03}	$1.0 \times 10^{+03}$	$4 \times 10^{+01}$	6×10^{-03}
Cf-249		$3.2 \times 10^{+00}$	$1.0 \times 10^{+03}$	7.6×10^{-04}	$4.6 \times 10^{+00}$	$3 \times 10^{+00}$	8×10^{-04}
Cf-250	a	$1.6 \times 10^{+01}$	$1.0 \times 10^{+03}$	1.6×10^{-03}	$1.0 \times 10^{+03}$	$2 \times 10^{+01}$	2×10^{-03}
Cf-251	a	$7.5 \times 10^{+00}$	$1.0 \times 10^{+03}$	7.5×10^{-04}	5.2×10^{-01}	$7 \times 10^{+00}$	7×10^{-04}
Cf-252		1.3×10^{-01}	$1.0 \times 10^{+03}$	2.8×10^{-03}	$5.2 \times 10^{+02}$	1×10^{-01}	3×10^{-03}
Cf-253	a	$4.2 \times 10^{+02}$	$1.0 \times 10^{+03}$	4.2×10^{-02}	$1.2 \times 10^{+00}$	$4 \times 10^{+01}$	4×10^{-02}
Cf-254		1.4×10^{-03}	$1.0 \times 10^{+03}$	1.4×10^{-03}	$1.0 \times 10^{+03}$	1×10^{-03}	1×10^{-03}
Cl-36		$1.0 \times 10^{+03}$	$1.0 \times 10^{+01}$	$7.2 \times 10^{+00}$	6.3×10^{-01}	$1 \times 10^{+01}$	6×10^{-01}
Cl-38		8.1×10^{-01}	2.2×10^{-01}	$1.0 \times 10^{+03}$	5.6×10^{-01}	2×10^{-01}	2×10^{-01}
Cm-240	a	$1.7 \times 10^{+02}$	$1.0 \times 10^{+03}$	1.7×10^{-02}	$1.0 \times 10^{+03}$	$4 \times 10^{+01}$	2×10^{-02}
Cm-241		$2.2 \times 10^{+00}$	$1.0 \times 10^{+03}$	$1.3 \times 10^{+00}$	$1.5 \times 10^{+00}$	$2 \times 10^{+00}$	$1 \times 10^{+00}$
Cm-242	a	$1.0 \times 10^{+02}$	$1.0 \times 10^{+03}$	1.0×10^{-02}	$1.0 \times 10^{+03}$	$4 \times 10^{+01}$	1×10^{-02}
Cm-243		$8.6 \times 10^{+00}$	$1.0 \times 10^{+03}$	1.3×10^{-03}	8.3×10^{-01}	$9 \times 10^{+00}$	1×10^{-03}

Radionuclide	a – Q _F tabulated in place of Q _A	Q _A or Q _F (TBq)	Q _B (TBq)	Q _C (TBq)	Q _D or Q _E (TBq)	A ₁ (TBq)	A ₂ (TBq)
Cm-244	a	$1.6 \times 10^{+01}$	$1.0 \times 10^{+03}$	1.6×10^{-03}	$1.0 \times 10^{+03}$	$2 \times 10^{+01}$	2×10^{-03}
Cm-245	a	$9.1 \times 10^{+00}$	$1.0 \times 10^{+03}$	9.1×10^{-04}	$2.7 \times 10^{+00}$	$9 \times 10^{+00}$	9×10^{-04}
Cm-246	a	$9.1 \times 10^{+00}$	$1.0 \times 10^{+03}$	9.1×10^{-04}	$1.0 \times 10^{+03}$	$9 \times 10^{+00}$	9×10^{-04}
Cm-247		$3.2 \times 10^{+00}$	$1.6 \times 10^{+02}$	9.8×10^{-04}	Unlimited	$3 \times 10^{+00}$	1×10^{-03}
Cm-248		1.8×10^{-02}	$1.0 \times 10^{+03}$	2.5×10^{-04}	Unlimited	2×10^{-02}	3×10^{-04}
Co-55		5.4×10^{-01}	9.7×10^{-01}	$9.1 \times 10^{+01}$	7.7×10^{-01}	5×10^{-01}	5×10^{-01}
Co-56		3.3×10^{-01}	$1.5 \times 10^{+01}$	$7.8 \times 10^{+00}$	$2.9 \times 10^{+00}$	3×10^{-01}	3×10^{-01}
Co-57		$1.0 \times 10^{+01}$	$1.0 \times 10^{+03}$	$5.3 \times 10^{+01}$	$1.3 \times 10^{+01}$	$1 \times 10^{+01}$	$1 \times 10^{+01}$
Co-58		$1.1 \times 10^{+00}$	$7.8 \times 10^{+02}$	$2.5 \times 10^{+01}$	$3.8 \times 10^{+00}$	$1 \times 10^{+00}$	$1 \times 10^{+00}$
Co-58m		$1.0 \times 10^{+03}$	$1.0 \times 10^{+03}$	$1.0 \times 10^{+03}$	$1.0 \times 10^{+03}$	$4 \times 10^{+01}$	$4 \times 10^{+01}$
Co-60		4.5×10^{-01}	$7.3 \times 10^{+02}$	$1.7 \times 10^{+00}$	9.7×10^{-01}	4×10^{-01}	4×10^{-01}
Cr-51		$3.4 \times 10^{+01}$	$1.0 \times 10^{+03}$	$1.0 \times 10^{+03}$	$1.0 \times 10^{+03}$	$3 \times 10^{+01}$	$3 \times 10^{+01}$
Cs-129		$3.6 \times 10^{+00}$	$1.0 \times 10^{+03}$	$1.0 \times 10^{+03}$	$3.7 \times 10^{+01}$	$4 \times 10^{+00}$	$4 \times 10^{+00}$
Cs-131		$3.1 \times 10^{+01}$	$1.0 \times 10^{+03}$	$1.0 \times 10^{+03}$	$1.0 \times 10^{+03}$	$3 \times 10^{+01}$	$3 \times 10^{+01}$
Cs-132		$1.5 \times 10^{+00}$	$1.0 \times 10^{+03}$	$2.1 \times 10^{+02}$	$2.5 \times 10^{+01}$	$1 \times 10^{+00}$	$1 \times 10^{+00}$
Cs-134		6.9×10^{-01}	$3.6 \times 10^{+00}$	$7.4 \times 10^{+00}$	9.2×10^{-01}	7×10^{-01}	7×10^{-01}
Cs-134m		$3.7 \times 10^{+01}$	$1.0 \times 10^{+03}$	$1.0 \times 10^{+03}$	6.3×10^{-01}	$4 \times 10^{+01}$	6×10^{-01}
Cs-135		—	$1.0 \times 10^{+03}$	Unlimited	$1.5 \times 10^{+00}$	$4 \times 10^{+01}$	$1 \times 10^{+00}$
Cs-136		5.1×10^{-01}	$8.3 \times 10^{+02}$	$3.8 \times 10^{+01}$	7.0×10^{-01}	5×10^{-01}	5×10^{-01}
Cs-137		$1.8 \times 10^{+00}$	$8.2 \times 10^{+00}$	$1.0 \times 10^{+01}$	6.3×10^{-01}	$2 \times 10^{+00}$	6×10^{-01}
Cu-64		$5.6 \times 10^{+00}$	$1.1 \times 10^{+02}$	$4.2 \times 10^{+02}$	$1.1 \times 10^{+00}$	$6 \times 10^{+00}$	$1 \times 10^{+00}$
Cu-67		$1.0 \times 10^{+01}$	$4.1 \times 10^{+02}$	$8.6 \times 10^{+01}$	6.9×10^{-01}	$1 \times 10^{+01}$	7×10^{-01}
Dy-159		$2.0 \times 10^{+01}$	$1.0 \times 10^{+03}$	$1.4 \times 10^{+02}$	$1.0 \times 10^{+03}$	$2 \times 10^{+01}$	$2 \times 10^{+01}$
Dy-165		$4.1 \times 10^{+01}$	9.4×10^{-01}	$8.2 \times 10^{+02}$	6.1×10^{-01}	9×10^{-01}	6×10^{-01}

Radionuclide	a – Q _F tabulated in place of Q _A	Q _A or Q _F (TBq)	Q _B (TBq)	Q _C (TBq)	Q _D or Q _E (TBq)	A ₁ (TBq)	A ₂ (TBq)
Dy-166		$3.4 \times 10^{+01}$	8.6×10^{-01}	$2.0 \times 10^{+01}$	3.4×10^{-01}	9×10^{-01}	3×10^{-01}
Er-169		$1.0 \times 10^{+03}$	$1.0 \times 10^{+03}$	$5.1 \times 10^{+01}$	9.5×10^{-01}	$4 \times 10^{+01}$	$1 \times 10^{+00}$
Er-171		$2.9 \times 10^{+00}$	8.3×10^{-01}	$2.3 \times 10^{+02}$	5.1×10^{-01}	8×10^{-01}	5×10^{-01}
Eu-147		$2.2 \times 10^{+00}$	$1.0 \times 10^{+03}$	$5.0 \times 10^{+01}$	$3.8 \times 10^{+00}$	$2 \times 10^{+00}$	$2 \times 10^{+00}$
Eu-148		5.1×10^{-01}	$1.0 \times 10^{+03}$	$1.9 \times 10^{+01}$	$1.9 \times 10^{+01}$	5×10^{-01}	5×10^{-01}
Eu-149		$1.5 \times 10^{+01}$	$1.0 \times 10^{+03}$	$1.9 \times 10^{+02}$	$7.4 \times 10^{+01}$	$2 \times 10^{+01}$	$2 \times 10^{+01}$
Eu-150 (34 y)		7.2×10^{-01}	$1.0 \times 10^{+03}$	$1.0 \times 10^{+00}$	$7.1 \times 10^{+00}$	7×10^{-01}	7×10^{-01}
Eu-150 (13 h)		$2.3 \times 10^{+01}$	$1.5 \times 10^{+00}$	$2.6 \times 10^{+02}$	6.9×10^{-01}	$2 \times 10^{+00}$	7×10^{-01}
Eu-152		9.6×10^{-01}	$1.7 \times 10^{+02}$	$1.3 \times 10^{+00}$	$1.3 \times 10^{+00}$	$1 \times 10^{+00}$	$1 \times 10^{+00}$
Eu-152m		$3.7 \times 10^{+00}$	8.1×10^{-01}	$2.3 \times 10^{+02}$	7.8×10^{-01}	8×10^{-01}	8×10^{-01}
Eu-154		9.0×10^{-01}	$1.6 \times 10^{+00}$	$1.0 \times 10^{+00}$	5.5×10^{-01}	9×10^{-01}	6×10^{-01}
Eu-155		$1.9 \times 10^{+01}$	$1.0 \times 10^{+03}$	$7.7 \times 10^{+00}$	$3.2 \times 10^{+00}$	$2 \times 10^{+01}$	$3 \times 10^{+00}$
Eu-156		8.8×10^{-01}	7.4×10^{-01}	$1.5 \times 10^{+01}$	6.7×10^{-01}	7×10^{-01}	7×10^{-01}
F-18		$1.0 \times 10^{+00}$	$2.8 \times 10^{+01}$	$8.3 \times 10^{+02}$	5.8×10^{-01}	$1 \times 10^{+00}$	6×10^{-01}
Fe-52		4.1×10^{-01}	3.2×10^{-01}	$7.6 \times 10^{+01}$	3.7×10^{-01}	3×10^{-01}	3×10^{-01}
Fe-55		$1.0 \times 10^{+03}$	$1.0 \times 10^{+03}$	$6.5 \times 10^{+01}$	$1.0 \times 10^{+03}$	$4 \times 10^{+01}$	$4 \times 10^{+01}$
Fe-59		9.4×10^{-01}	$4.4 \times 10^{+01}$	$1.4 \times 10^{+01}$	8.9×10^{-01}	9×10^{-01}	9×10^{-01}
Fe-60		$2.0 \times 10^{+02}$	$1.0 \times 10^{+03}$	2.1×10^{-01}	$3.7 \times 10^{+00}$	$4 \times 10^{+01}$	2×10^{-01}
Ga-67		$7.4 \times 10^{+00}$	$1.0 \times 10^{+03}$	$2.2 \times 10^{+02}$	$3.2 \times 10^{+00}$	$7 \times 10^{+00}$	$3 \times 10^{+00}$
Ga-68		$1.1 \times 10^{+00}$	4.6×10^{-01}	$9.8 \times 10^{+02}$	6.6×10^{-01}	5×10^{-01}	5×10^{-01}
Ga-72		4.3×10^{-01}	3.7×10^{-01}	$9.1 \times 10^{+01}$	6.2×10^{-01}	4×10^{-01}	4×10^{-01}
Gd-146		5.3×10^{-01}	$2.9 \times 10^{+02}$	$7.3 \times 10^{+00}$	$1.0 \times 10^{+00}$	5×10^{-01}	5×10^{-01}
Gd-148	a	$2.0 \times 10^{+01}$	—	2.0×10^{-05}	—	$2 \times 10^{+01}$	2×10^{-05}
Gd-153		$9.5 \times 10^{+00}$	$1.0 \times 10^{+03}$	$2.4 \times 10^{+01}$	$8.9 \times 10^{+00}$	$1 \times 10^{+01}$	$9 \times 10^{+00}$

Radionuclide	a – Q _F tabulated in place of Q _A	Q _A or Q _F (TBq)	Q _B (TBq)	Q _C (TBq)	Q _D or Q _E (TBq)	A ₁ (TBq)	A ₂ (TBq)
Gd-159		$2.1 \times 10^{+01}$	$3.1 \times 10^{+00}$	$1.9 \times 10^{+02}$	6.4×10^{-01}	$3 \times 10^{+00}$	6×10^{-01}
Ge-68		$1.1 \times 10^{+00}$	4.6×10^{-01}	$3.8 \times 10^{+00}$	6.6×10^{-01}	5×10^{-01}	5×10^{-01}
Ge-69		$1.1 \times 10^{+00}$	$2.2 \times 10^{+00}$	$1.6 \times 10^{+02}$	$1.7 \times 10^{+00}$	$1 \times 10^{+00}$	$1 \times 10^{+00}$
Ge-71		$5.2 \times 10^{+02}$	$1.0 \times 10^{+03}$	$1.0 \times 10^{+03}$	$1.0 \times 10^{+03}$	$4 \times 10^{+01}$	$4 \times 10^{+01}$
Ge-77		$1.1 \times 10^{+00}$	3.3×10^{-01}	$1.4 \times 10^{+02}$	6.0×10^{-01}	3×10^{-01}	3×10^{-01}
Hf-172		5.8×10^{-01}	$1.0 \times 10^{+03}$	$1.5 \times 10^{+00}$	$1.7 \times 10^{+00}$	6×10^{-01}	6×10^{-01}
Hf-175		$2.9 \times 10^{+00}$	$1.0 \times 10^{+03}$	$4.5 \times 10^{+01}$	$4.7 \times 10^{+00}$	$3 \times 10^{+00}$	$3 \times 10^{+00}$
Hf-181		$1.9 \times 10^{+00}$	$1.0 \times 10^{+03}$	$1.1 \times 10^{+01}$	5.0×10^{-01}	$2 \times 10^{+00}$	5×10^{-01}
Hf-182		$4.6 \times 10^{+00}$	$1.0 \times 10^{+03}$	Unlimited	Unlimited	Unlimited	Unlimited
Hg-194		$1.1 \times 10^{+00}$	$1.0 \times 10^{+03}$	$1.3 \times 10^{+00}$	$6.1 \times 10^{+00}$	$1 \times 10^{+00}$	$1 \times 10^{+00}$
Hg-195m		$3.1 \times 10^{+00}$	$1.0 \times 10^{+03}$	$5.3 \times 10^{+00}$	7.3×10^{-01}	$3 \times 10^{+00}$	7×10^{-01}
Hg-197		$1.6 \times 10^{+01}$	$1.0 \times 10^{+03}$	$1.1 \times 10^{+01}$	$1.6 \times 10^{+01}$	$2 \times 10^{+01}$	$1 \times 10^{+01}$
Hg-197m		$1.3 \times 10^{+01}$	$1.0 \times 10^{+03}$	$8.1 \times 10^{+00}$	3.5×10^{-01}	$1 \times 10^{+01}$	4×10^{-01}
Hg-203		$4.6 \times 10^{+00}$	$1.0 \times 10^{+03}$	$6.7 \times 10^{+00}$	$1.1 \times 10^{+00}$	$5 \times 10^{+00}$	$1 \times 10^{+00}$
Ho-166		$3.8 \times 10^{+01}$	4.4×10^{-01}	$7.6 \times 10^{+01}$	5.8×10^{-01}	4×10^{-01}	4×10^{-01}
Ho-166m		6.2×10^{-01}	$1.0 \times 10^{+03}$	4.5×10^{-01}	$1.3 \times 10^{+00}$	6×10^{-01}	5×10^{-01}
I-123		$6.3 \times 10^{+00}$	$1.0 \times 10^{+03}$	$2.3 \times 10^{+02}$	$2.9 \times 10^{+00}$	$6 \times 10^{+00}$	$3 \times 10^{+00}$
I-124		$1.1 \times 10^{+00}$	$6.0 \times 10^{+00}$	$3.8 \times 10^{+00}$	$2.5 \times 10^{+00}$	$1 \times 10^{+00}$	$1 \times 10^{+00}$
I-125		$1.6 \times 10^{+01}$	$1.0 \times 10^{+03}$	$3.3 \times 10^{+00}$	$1.0 \times 10^{+03}$	$2 \times 10^{+01}$	$3 \times 10^{+00}$
I-126		$2.3 \times 10^{+00}$	$6.4 \times 10^{+00}$	$1.7 \times 10^{+00}$	$1.3 \times 10^{+00}$	$2 \times 10^{+00}$	$1 \times 10^{+00}$
I-129		$2.9 \times 10^{+01}$	$1.0 \times 10^{+03}$	Unlimited	Unlimited	Unlimited	Unlimited
I-131		$2.8 \times 10^{+00}$	$2.0 \times 10^{+01}$	$2.3 \times 10^{+00}$	6.9×10^{-01}	$3 \times 10^{+00}$	7×10^{-01}
I-132		4.8×10^{-01}	4.4×10^{-01}	$1.8 \times 10^{+02}$	6.1×10^{-01}	4×10^{-01}	4×10^{-01}
I-133		$1.8 \times 10^{+00}$	7.3×10^{-01}	$1.1 \times 10^{+01}$	6.2×10^{-01}	7×10^{-01}	6×10^{-01}
I-134		4.2×10^{-01}	3.2×10^{-01}	$6.9 \times 10^{+02}$	5.9×10^{-01}	3×10^{-01}	3×10^{-01}

Radionuclide	a – Q _F tabulated in place of Q _A	Q _A or Q _F (TBq)	Q _B (TBq)	Q _C (TBq)	Q _D or Q _E (TBq)	A ₁ (TBq)	A ₂ (TBq)
I-135		8.2×10^{-01}	6.2×10^{-01}	$5.2 \times 10^{+01}$	6.2×10^{-01}	6×10^{-01}	6×10^{-01}
In-111		$2.8 \times 10^{+00}$	$1.0 \times 10^{+03}$	$2.2 \times 10^{+02}$	$3.0 \times 10^{+00}$	$3 \times 10^{+00}$	$3 \times 10^{+00}$
In-113m		$4.1 \times 10^{+00}$	$1.0 \times 10^{+03}$	$1.0 \times 10^{+03}$	$1.6 \times 10^{+00}$	$4 \times 10^{+00}$	$2 \times 10^{+00}$
In-114m		$1.1 \times 10^{+01}$	$1.0 \times 10^{+03}$	$5.4 \times 10^{+00}$	4.8×10^{-01}	$1 \times 10^{+01}$	5×10^{-01}
In-115m		$6.5 \times 10^{+00}$	$1.0 \times 10^{+03}$	$8.3 \times 10^{+02}$	$1.0 \times 10^{+00}$	$7 \times 10^{+00}$	$1 \times 10^{+00}$
Ir-189		$1.3 \times 10^{+01}$	$1.0 \times 10^{+03}$	$9.1 \times 10^{+01}$	$1.8 \times 10^{+01}$	$1 \times 10^{+01}$	$1 \times 10^{+01}$
Ir-190		7.5×10^{-01}	$1.0 \times 10^{+03}$	$2.2 \times 10^{+01}$	7.5×10^{-01}	7×10^{-01} $1 \times 10^{+00}$	7×10^{-01}
Ir-192		$1.3 \times 10^{+00}$	$4.6 \times 10^{+01}$	$8.1 \times 10^{+00}$	6.1×10^{-01}		6×10^{-01}
Ir-193m		$7.7 \times 10^{+02}$	$1.0 \times 10^{+03}$	$3.8 \times 10^{+01}$	$3.0 \times 10^{+00}$	$4 \times 10^{+01}$	$4 \times 10^{+00}$
Ir-194		$1.2 \times 10^{+01}$	3.3×10^{-01}	$8.9 \times 10^{+01}$	5.9×10^{-01}	3×10^{-01}	3×10^{-01}
K-40		$7.3 \times 10^{+00}$	9.4×10^{-01}	Unlimited	Unlimited	9×10^{-01}	9×10^{-01}
K-42		$4.2 \times 10^{+00}$	2.2×10^{-01}	$3.8 \times 10^{+02}$	5.7×10^{-01}	2×10^{-01}	2×10^{-01}
K-43		$1.1 \times 10^{+00}$	7.3×10^{-01}	$3.3 \times 10^{+02}$	6.2×10^{-01}	7×10^{-01}	6×10^{-01}
Kr-81		$1.1 \times 10^{+02}$	$1.0 \times 10^{+03}$	—	$7.9 \times 10^{+01}$	$4 \times 10^{+01}$	$4 \times 10^{+01}$
Kr-85		$4.8 \times 10^{+02}$	$1.4 \times 10^{+01}$	—	$1.4 \times 10^{+01}$	$1 \times 10^{+01}$	$1 \times 10^{+01}$
Kr-85m		$7.5 \times 10^{+00}$	$7.6 \times 10^{+00}$	—	$2.8 \times 10^{+00}$	$8 \times 10^{+00}$	$3 \times 10^{+00}$
Kr-87		$1.5 \times 10^{+00}$	2.1×10^{-01}	—	4.8×10^{-01}	2×10^{-01}	2×10^{-01}
La-137		$3.0 \times 10^{+01}$	$1.0 \times 10^{+03}$	$5.7 \times 10^{+00}$	$1.0 \times 10^{+03}$	$3 \times 10^{+01}$	$6 \times 10^{+00}$
La-140		4.9×10^{-01}	3.7×10^{-01}	$4.5 \times 10^{+01}$	6.0×10^{-01}	4×10^{-01}	4×10^{-01}
Lu-172		5.9×10^{-01}	$1.0 \times 10^{+03}$	$3.3 \times 10^{+01}$	$2.2 \times 10^{+00}$	6×10^{-01}	6×10^{-01}
Lu-173		$8.0 \times 10^{+00}$	$1.0 \times 10^{+03}$	$2.2 \times 10^{+01}$	$1.7 \times 10^{+01}$	$8 \times 10^{+00}$	$8 \times 10^{+00}$
Lu-174		$8.5 \times 10^{+00}$	$1.0 \times 10^{+03}$	$1.3 \times 10^{+01}$	$2.9 \times 10^{+01}$	$9 \times 10^{+00}$	$9 \times 10^{+00}$
Lu-174m		$1.6 \times 10^{+01}$	$1.0 \times 10^{+03}$	$1.3 \times 10^{+01}$	$3.7 \times 10^{+01}$	$2 \times 10^{+01}$	$1 \times 10^{+01}$
Lu-177		$3.3 \times 10^{+01}$	$1.0 \times 10^{+03}$	$4.2 \times 10^{+01}$	7.3×10^{-01}	$3 \times 10^{+01}$	7×10^{-01}

Radionuclide	a – Q _F tabulated in place of Q _A	Q _A or Q _F (TBq)	Q _B (TBq)	Q _C (TBq)	Q _D or Q _E (TBq)	A ₁ (TBq)	A ₂ (TBq)
Mg-28		3.7×10^{-01}	2.5×10^{-01}	$2.6 \times 10^{+01}$	3.2×10^{-01}	3×10^{-01}	3×10^{-01}
Mn-52		3.2×10^{-01}	$7.3 \times 10^{+02}$	$3.6 \times 10^{+01}$	$1.9 \times 10^{+00}$	3×10^{-01}	3×10^{-01}
Mn-53		$1.0 \times 10^{+03}$	$1.0 \times 10^{+03}$	Unlimited	Unlimited	Unlimited	Unlimited
Mn-54		$1.3 \times 10^{+00}$	$1.0 \times 10^{+03}$	$3.3 \times 10^{+01}$	$1.0 \times 10^{+03}$	$1 \times 10^{+00}$	$1 \times 10^{+00}$
Mn-56		6.7×10^{-01}	3.0×10^{-01}	$3.8 \times 10^{+02}$	6.0×10^{-01}	3×10^{-01}	3×10^{-01}
Mo-93		$8.6 \times 10^{+01}$	$1.0 \times 10^{+03}$	$2.3 \times 10^{+01}$	$1.0 \times 10^{+03}$	$4 \times 10^{+01}$	$2 \times 10^{+01}$
Mo-99		$6.2 \times 10^{+00}$	$1.3 \times 10^{+00}$	$5.1 \times 10^{+01}$	5.5×10^{-01}	$1 \times 10^{+00}$	6×10^{-01}
N-13		$1.0 \times 10^{+00}$	9.3×10^{-01}	—	5.8×10^{-01}	9×10^{-01}	6×10^{-01}
Na-22		5.0×10^{-01}	$3.8 \times 10^{+00}$	$3.8 \times 10^{+01}$	6.5×10^{-01}	5×10^{-01}	5×10^{-01}
Na-24		3.0×10^{-01}	2.0×10^{-01}	$1.7 \times 10^{+02}$	6.0×10^{-01}	2×10^{-01}	2×10^{-01}
Nb-93m		$4.9 \times 10^{+02}$	$1.0 \times 10^{+03}$	$3.1 \times 10^{+01}$	$1.0 \times 10^{+03}$	$4 \times 10^{+01}$	$3 \times 10^{+01}$
Nb-94		6.8×10^{-01}	$1.0 \times 10^{+03}$	$1.1 \times 10^{+00}$	7.0×10^{-01}	7×10^{-01}	7×10^{-01}
Nb-95		$1.4 \times 10^{+00}$	$1.0 \times 10^{+03}$	$3.1 \times 10^{+01}$	$4.0 \times 10^{+00}$	$1 \times 10^{+00}$	$1 \times 10^{+00}$
Nb-97		$1.6 \times 10^{+00}$	9.0×10^{-01}	$1.0 \times 10^{+03}$	6.1×10^{-01}	9×10^{-01}	6×10^{-01}
Nd-147		$7.4 \times 10^{+00}$	$5.6 \times 10^{+00}$	$2.2 \times 10^{+01}$	6.5×10^{-01}	$6 \times 10^{+00}$	6×10^{-01}
Nd-149		$2.9 \times 10^{+00}$	6.3×10^{-01}	$5.6 \times 10^{+02}$	5.1×10^{-01}	6×10^{-01}	5×10^{-01}
Ni-57		5.9×10^{-01}	$6.8 \times 10^{+00}$	$8.9 \times 10^{+01}$	$1.3 \times 10^{+00}$	6×10^{-01}	6×10^{-01}
Ni-59		$1.0 \times 10^{+03}$	$1.0 \times 10^{+03}$	Unlimited	Unlimited	Unlimited	Unlimited
Ni-63		—	$1.0 \times 10^{+03}$	$2.9 \times 10^{+01}$	$1.0 \times 10^{+03}$	$4 \times 10^{+01}$	$3 \times 10^{+01}$
Ni-65		$2.1 \times 10^{+00}$	4.4×10^{-01}	$5.7 \times 10^{+02}$	6.1×10^{-01}	4×10^{-01}	4×10^{-01}
Np-235		$1.4 \times 10^{+02}$	$1.0 \times 10^{+03}$	$1.3 \times 10^{+02}$	$1.0 \times 10^{+03}$	$4 \times 10^{+01}$	$4 \times 10^{+01}$
		$8.7 \times 10^{+00}$	$1.0 \times 10^{+03}$	1.7×10^{-02}	5.0×10^{-01}	$9 \times 10^{+00}$	2×10^{-02}

Radionuclide	a – Q _F tabulated in place of Q _A	Q _A or Q _F (TBq)	Q _B (TBq)	Q _C (TBq)	Q _D or Q _E (TBq)	A ₁ (TBq)	A ₂ (TBq)
Np-236 (0.1 My)							
Np-236 (22 h)		$2.3 \times 10^{+01}$	$1.0 \times 10^{+03}$	$1.0 \times 10^{+01}$	$1.5 \times 10^{+00}$	$2 \times 10^{+01}$	$2 \times 10^{+00}$
Np-237	a	$2.4 \times 10^{+01}$	$1.0 \times 10^{+03}$	2.4×10^{-03}	Unlimited	$2 \times 10^{+01}$	2×10^{-03}
Np-239		$6.7 \times 10^{+00}$	$2.6 \times 10^{+02}$	$5.6 \times 10^{+01}$	4.1×10^{-01}	$7 \times 10^{+00}$	4×10^{-01}
Os-185		$1.5 \times 10^{+00}$	$1.0 \times 10^{+03}$	$3.3 \times 10^{+01}$	$2.3 \times 10^{+01}$	$1 \times 10^{+00}$	$1 \times 10^{+00}$
Os-191		$1.5 \times 10^{+01}$	$1.0 \times 10^{+03}$	$2.8 \times 10^{+01}$	$2.3 \times 10^{+00}$	$1 \times 10^{+01}$	$2 \times 10^{+00}$
Os-191m		$1.3 \times 10^{+02}$	$1.0 \times 10^{+03}$	$3.3 \times 10^{+02}$	$2.7 \times 10^{+01}$	$4 \times 10^{+01}$	$3 \times 10^{+01}$
Os-193		$1.5 \times 10^{+01}$	$1.6 \times 10^{+00}$	$9.8 \times 10^{+01}$	5.9×10^{-01}	$2 \times 10^{+00}$	6×10^{-01}
Os-194		$1.2 \times 10^{+01}$	3.1×10^{-01}	6.3×10^{-01}	5.9×10^{-01}	3×10^{-01}	3×10^{-01}
P-32		—	4.5×10^{-01}	$1.6 \times 10^{+01}$	6.0×10^{-01}	5×10^{-01}	5×10^{-01}
P-33		—	$1.0 \times 10^{+03}$	$3.6 \times 10^{+01}$	$1.2 \times 10^{+00}$	$4 \times 10^{+01}$	$1 \times 10^{+00}$
Pa-230		$1.7 \times 10^{+00}$	$1.0 \times 10^{+03}$	6.6×10^{-02}	$2.1 \times 10^{+00}$	$2 \times 10^{+00}$	7×10^{-02}
Pa-231	a	$3.8 \times 10^{+00}$	$1.0 \times 10^{+03}$	3.8×10^{-04}	$1.8 \times 10^{+01}$	$4 \times 10^{+00}$	4×10^{-04}
Pa-233		$5.4 \times 10^{+00}$	$1.0 \times 10^{+03}$	$1.4 \times 10^{+01}$	6.5×10^{-01}	$5 \times 10^{+00}$	7×10^{-01}
Pb-201		$1.5 \times 10^{+00}$	$1.0 \times 10^{+03}$	$7.7 \times 10^{+02}$	$3.3 \times 10^{+00}$	$1 \times 10^{+00}$	$1 \times 10^{+00}$
Pb-202		$9.0 \times 10^{+02}$	$1.0 \times 10^{+03}$	Unlimited	$1.6 \times 10^{+01}$	$4 \times 10^{+01}$	$2 \times 10^{+01}$
Pb-203		$3.6 \times 10^{+00}$	$1.0 \times 10^{+03}$	$5.5 \times 10^{+02}$	$2.6 \times 10^{+00}$	$4 \times 10^{+00}$	$3 \times 10^{+00}$
Pb-205		$8.3 \times 10^{+02}$	$1.0 \times 10^{+03}$	Unlimited	Unlimited	Unlimited	Unlimited
Pb-210		$2.4 \times 10^{+02}$	$1.3 \times 10^{+00}$	5.1×10^{-02}	6.2×10^{-01}	$1 \times 10^{+00}$	5×10^{-02}
Pb-212		$1.0 \times 10^{+00}$	7.0×10^{-01}	2.2×10^{-01}	2.7×10^{-01}	7×10^{-01}	2×10^{-01}
Pd-103		$4.7 \times 10^{+01}$	$1.0 \times 10^{+03}$	$1.2 \times 10^{+02}$	$1.0 \times 10^{+03}$	$4 \times 10^{+01}$	$4 \times 10^{+01}$
Pd-107		—	$1.0 \times 10^{+03}$	Unlimited	Unlimited	Unlimited	Unlimited
Pd-109		$7.0 \times 10^{+01}$	$1.9 \times 10^{+00}$	$1.4 \times 10^{+02}$	4.7×10^{-01}	$2 \times 10^{+00}$	5×10^{-01}

Radionuclide	a – Q _F tabulated in place of Q _A	Q _A or Q _F (TBq)	Q _B (TBq)	Q _C (TBq)	Q _D or Q _E (TBq)	A ₁ (TBq)	A ₂ (TBq)
Pm-143		$3.3 \times 10^{+00}$	$1.0 \times 10^{+03}$	$3.6 \times 10^{+01}$	$3.6 \times 10^{+02}$	$3 \times 10^{+00}$	$3 \times 10^{+00}$
Pm-144		6.7×10^{-01}	$1.0 \times 10^{+03}$	$6.4 \times 10^{+00}$	$3.4 \times 10^{+01}$	7×10^{-01}	7×10^{-01}
Pm-145		$2.6 \times 10^{+01}$	$1.0 \times 10^{+03}$	$1.5 \times 10^{+01}$	$1.0 \times 10^{+03}$	$3 \times 10^{+01}$	$1 \times 10^{+01}$
Pm-147		$1.0 \times 10^{+03}$	$1.0 \times 10^{+03}$	$1.1 \times 10^{+01}$	$1.7 \times 10^{+00}$	$4 \times 10^{+01}$	$2 \times 10^{+00}$
Pm-148m		8.3×10^{-01}	$7.6 \times 10^{+00}$	$9.1 \times 10^{+00}$	7.2×10^{-01}	8×10^{-01}	7×10^{-01}
Pm-149		$1.0 \times 10^{+02}$	$1.7 \times 10^{+00}$	$6.9 \times 10^{+01}$	6.2×10^{-01}	$2 \times 10^{+00}$	6×10^{-01}
Pm-151		$3.3 \times 10^{+00}$	$1.8 \times 10^{+00}$	$1.1 \times 10^{+02}$	6.1×10^{-01}	$2 \times 10^{+00}$	6×10^{-01}
Po-210	a	$1.7 \times 10^{+02}$	$1.0 \times 10^{+03}$	1.7×10^{-02}	$1.0 \times 10^{+03}$	$4 \times 10^{+01}$	2×10^{-02}
Pr-142		$2.0 \times 10^{+01}$	3.6×10^{-01}	$8.9 \times 10^{+01}$	6.0×10^{-01}	4×10^{-01}	4×10^{-01}
Pr-143		$1.0 \times 10^{+03}$	$3.0 \times 10^{+00}$	$2.2 \times 10^{+01}$	6.3×10^{-01}	$3 \times 10^{+00}$	6×10^{-01}
Pt-188		9.7×10^{-01}	$1.0 \times 10^{+03}$	$5.7 \times 10^{+01}$	7.8×10^{-01}	$1 \times 10^{+00}$	8×10^{-01}
Pt-191		$3.6 \times 10^{+00}$	$1.0 \times 10^{+03}$	$4.5 \times 10^{+02}$	$3.5 \times 10^{+00}$	$4 \times 10^{+00}$	$3 \times 10^{+00}$
Pt-193		$8.7 \times 10^{+02}$	$1.0 \times 10^{+03}$	$1.0 \times 10^{+03}$	$1.0 \times 10^{+03}$	$4 \times 10^{+01}$	$4 \times 10^{+01}$
Pt-193m		$9.1 \times 10^{+01}$	$1.0 \times 10^{+03}$	$3.8 \times 10^{+02}$	5.5×10^{-01}	$4 \times 10^{+01}$	5×10^{-01}
Pt-195m		$1.5 \times 10^{+01}$	$1.0 \times 10^{+03}$	$2.6 \times 10^{+02}$	4.8×10^{-01}	$1 \times 10^{+01}$	5×10^{-01}
Pt-197		$4.7 \times 10^{+01}$	$2.4 \times 10^{+01}$	$5.5 \times 10^{+02}$	6.3×10^{-01}	$2 \times 10^{+01}$	6×10^{-01}
Pt-197m		$1.3 \times 10^{+01}$	$1.0 \times 10^{+03}$	$1.0 \times 10^{+03}$	5.8e-01	$1 \times 10^{+01}$	6×10^{-01}
Pu-236	a	$2.8 \times 10^{+01}$	$1.0 \times 10^{+03}$	2.8×10^{-03}	$6.5 \times 10^{+02}$	$3 \times 10^{+01}$	3×10^{-03}
Pu-237		$2.3 \times 10^{+01}$	$1.0 \times 10^{+03}$	$1.4 \times 10^{+02}$	$1.2 \times 10^{+02}$	$2 \times 10^{+01}$	$2 \times 10^{+01}$
Pu-238	a	$1.2 \times 10^{+01}$	$1.0 \times 10^{+03}$	1.2×10^{-03}	$1.0 \times 10^{+03}$	$1 \times 10^{+01}$	1×10^{-03}
Pu-239	a	$1.1 \times 10^{+01}$	$1.0 \times 10^{+03}$	1.1×10^{-03}	Unlimited	$1 \times 10^{+01}$	1×10^{-03}
Pu-240	a	$1.1 \times 10^{+01}$	$1.0 \times 10^{+03}$	1.1×10^{-03}	Unlimited	$1 \times 10^{+01}$	1×10^{-03}
Pu-241		$1.0 \times 10^{+03}$	$1.0 \times 10^{+03}$	5.9×10^{-02}	$1.0 \times 10^{+03}$	$4 \times 10^{+01}$	6×10^{-02}
Pu-242	a	$1.1 \times 10^{+01}$	$1.0 \times 10^{+03}$	1.1×10^{-03}	Unlimited	$1 \times 10^{+01}$	1×10^{-03}
Pu-244		$3.1 \times 10^{+00}$	3.8×10^{-01}	1.1×10^{-03}	Unlimited	4×10^{-01}	1×10^{-03}

Radionuclide	a – Q _F tabulated in place of Q _A	Q _A or Q _F (TBq)	Q _B (TBq)	Q _C (TBq)	Q _D or Q _E (TBq)	A ₁ (TBq)	A ₂ (TBq)
Ra-223		$3.9 \times 10^{+00}$	4.0×10^{-01}	7.2×10^{-03}	2.6×10^{-01}	4×10^{-01}	7×10^{-03}
Ra-224		$1.1 \times 10^{+00}$	4.3×10^{-01}	1.6×10^{-02}	2.7×10^{-01}	4×10^{-01}	2×10^{-02}
Ra-225		$1.2 \times 10^{+01}$	2.2×10^{-01}	3.6×10^{-03}	2.3×10^{-01}	2×10^{-01}	4×10^{-03}
Ra-226		6.5×10^{-01}	2.5×10^{-01}	2.7×10^{-03}	2.7×10^{-01}	2×10^{-01}	3×10^{-03}
Ra-228		$1.2 \times 10^{+00}$	5.6×10^{-01}	1.9×10^{-02}	5.2×10^{-01}	6×10^{-01}	2×10^{-02}
Rb-81		$1.7 \times 10^{+00}$	$1.5 \times 10^{+01}$	$1.0 \times 10^{+03}$	8.3×10^{-01}	$2 \times 10^{+00}$	8×10^{-01}
Rb-83		$2.1 \times 10^{+00}$	$1.0 \times 10^{+03}$	$6.9 \times 10^{+01}$	$4.3 \times 10^{+02}$	$2 \times 10^{+00}$	$2 \times 10^{+00}$
Rb-84		$1.2 \times 10^{+00}$	$4.0 \times 10^{+01}$	$4.5 \times 10^{+01}$	$2.2 \times 10^{+00}$	$1 \times 10^{+00}$	$1 \times 10^{+00}$
Rb-86		$1.2 \times 10^{+01}$	4.8×10^{-01}	$5.2 \times 10^{+01}$	6.1×10^{-01}	5×10^{-01}	5×10^{-01}
Rb-87		—	$1.0 \times 10^{+03}$	Unlimited	Unlimited	Unlimited	Unlimited
Rb(nat)		—	$1.0 \times 10^{+03}$	Unlimited	Unlimited	Unlimited	Unlimited
Re-184		$1.2 \times 10^{+00}$	$1.0 \times 10^{+03}$	$2.8 \times 10^{+01}$	$1.7 \times 10^{+00}$	$1 \times 10^{+00}$	$1 \times 10^{+00}$
Re-184m		$2.8 \times 10^{+00}$	$1.0 \times 10^{+03}$	$8.2 \times 10^{+00}$	$1.2 \times 10^{+00}$	$3 \times 10^{+00}$	$1 \times 10^{+00}$
Re-186		$5.8 \times 10^{+01}$	$2.0 \times 10^{+00}$	$4.5 \times 10^{+01}$	5.9×10^{-01}	$2 \times 10^{+00}$	6×10^{-01}
Re-187		—	$1.0 \times 10^{+03}$	Unlimited	Unlimited	Unlimited	Unlimited
Re-188		$2.0 \times 10^{+01}$	3.5×10^{-01}	$9.1 \times 10^{+01}$	5.4×10^{-01}	4×10^{-01}	4×10^{-01}
Re-189		$3.2 \times 10^{+01}$	$2.5 \times 10^{+00}$	$1.2 \times 10^{+02}$	5.7×10^{-01}	$3 \times 10^{+00}$	6×10^{-01}
Re(nat)		—	$1.0 \times 10^{+03}$	Unlimited	Unlimited	Unlimited	Unlimited
Rh-99		$1.8 \times 10^{+00}$	$1.0 \times 10^{+03}$	$6.0 \times 10^{+01}$	$7.5 \times 10^{+00}$	$2 \times 10^{+00}$	$2 \times 10^{+00}$
Rh-101		$4.3 \times 10^{+00}$	$1.0 \times 10^{+03}$	$9.8 \times 10^{+00}$	$2.6 \times 10^{+00}$	$4 \times 10^{+00}$	$3 \times 10^{+00}$
Rh-102		5.0×10^{-01}	$1.0 \times 10^{+03}$	$3.1 \times 10^{+00}$	$5.4 \times 10^{+01}$	5×10^{-01}	5×10^{-01}
Rh-102m		$2.2 \times 10^{+00}$	$8.9 \times 10^{+00}$	$7.5 \times 10^{+00}$	$1.8 \times 10^{+00}$	$2 \times 10^{+00}$	$2 \times 10^{+00}$
Rh-103m		$4.5 \times 10^{+02}$	$1.0 \times 10^{+03}$	$1.0 \times 10^{+03}$	$1.0 \times 10^{+03}$	$4 \times 10^{+01}$	$4 \times 10^{+01}$
Rh-105		$1.4 \times 10^{+01}$	$1.8 \times 10^{+02}$	$1.5 \times 10^{+02}$	7.9×10^{-01}	$1 \times 10^{+01}$	8×10^{-01}
Rn-222		6.7×10^{-01}	2.6×10^{-01}	—	4.2×10^{-03}	3×10^{-01}	4×10^{-03}

Radionuclide	a – Q _F tabulated in place of Q _A	Q _A or Q _F (TBq)	Q _B (TBq)	Q _C (TBq)	Q _D or Q _E (TBq)	A ₁ (TBq)	A ₂ (TBq)
Ru-97		$4.7 \times 10^{+00}$	$1.0 \times 10^{+03}$	$4.5 \times 10^{+02}$	$1.3 \times 10^{+01}$	$5 \times 10^{+00}$	$5 \times 10^{+00}$
Ru-103		$2.2 \times 10^{+00}$	$2.0 \times 10^{+02}$	$1.8 \times 10^{+01}$	$1.6 \times 10^{+00}$	$2 \times 10^{+00}$	$2 \times 10^{+00}$
Ru-105		$1.4 \times 10^{+00}$	$1.2 \times 10^{+00}$	$2.8 \times 10^{+02}$	6.1×10^{-01}	$1 \times 10^{+00}$	6×10^{-01}
Ru-106		$5.3 \times 10^{+00}$	2.2×10^{-01}	8.1×10^{-01}	5.7×10^{-01}	2×10^{-01}	2×10^{-01}
S-35		—	$1.0 \times 10^{+03}$	$3.8 \times 10^{+01}$	$3.0 \times 10^{+00}$	$4 \times 10^{+01}$	$3 \times 10^{+00}$
Sb-122		$2.4 \times 10^{+00}$	4.3×10^{-01}	$5.0 \times 10^{+01}$	6.2×10^{-01}	4×10^{-01}	4×10^{-01}
Sb-124		6.2×10^{-01}	7.2×10^{-01}	$8.2 \times 10^{+00}$	6.9×10^{-01}	6×10^{-01}	6×10^{-01}
Sb-125		$2.4 \times 10^{+00}$	$2.5 \times 10^{+02}$	$1.1 \times 10^{+01}$	$1.4 \times 10^{+00}$	$2 \times 10^{+00}$	$1 \times 10^{+00}$
Sb-126		3.8×10^{-01}	$1.3 \times 10^{+00}$	$1.8 \times 10^{+01}$	7.1×10^{-01}	4×10^{-01}	4×10^{-01}
Sc-44		5.1×10^{-01}	6.1×10^{-01}	$2.6 \times 10^{+02}$	6.2×10^{-01}	5×10^{-01}	5×10^{-01}
Sc-46		5.4×10^{-01}	$1.0 \times 10^{+03}$	$7.8 \times 10^{+00}$	8.5×10^{-01}	5×10^{-01}	5×10^{-01}
Sc-47		$1.1 \times 10^{+01}$	$1.7 \times 10^{+02}$	$7.1 \times 10^{+01}$	7.0×10^{-01}	$1 \times 10^{+01}$	7×10^{-01}
Sc-48		3.3×10^{-01}	9.0×10^{-01}	$4.5 \times 10^{+01}$	6.5×10^{-01}	3×10^{-01}	3×10^{-01}
Se-75		$2.9 \times 10^{+00}$	$1.0 \times 10^{+03}$	$3.6 \times 10^{+01}$	$1.0 \times 10^{+01}$	$3 \times 10^{+00}$	$3 \times 10^{+00}$
Se-79		—	$1.0 \times 10^{+03}$	$1.7 \times 10^{+01}$	$2.3 \times 10^{+00}$	$4 \times 10^{+01}$	$2 \times 10^{+00}$
Si-31		$1.0 \times 10^{+03}$	5.8×10^{-01}	$6.3 \times 10^{+02}$	6.0×10^{-01}	6×10^{-01}	6×10^{-01}
Si-32		—	$1.0 \times 10^{+03}$	4.5×10^{-01}	$1.6 \times 10^{+00}$	$4 \times 10^{+01}$	5×10^{-01}
Sm-145		$1.3 \times 10^{+01}$	$1.0 \times 10^{+03}$	$3.3 \times 10^{+01}$	$1.0 \times 10^{+03}$	$1 \times 10^{+01}$	$1 \times 10^{+01}$
Sm-147		$5.6 \times 10^{+01}$	—	Unlimited	—	Unlimited	Unlimited
Sm-151		$1.0 \times 10^{+03}$	$1.0 \times 10^{+03}$	$1.4 \times 10^{+01}$	$1.0 \times 10^{+03}$	$4 \times 10^{+01}$	$1 \times 10^{+01}$
Sm-153		$1.7 \times 10^{+01}$	$9.1 \times 10^{+00}$	$8.2 \times 10^{+01}$	6.1×10^{-01}	$9 \times 10^{+00}$	6×10^{-01}
Sn-113		$3.7 \times 10^{+00}$	$1.0 \times 10^{+03}$	$2.0 \times 10^{+01}$	$1.6 \times 10^{+00}$	$4 \times 10^{+00}$	$2 \times 10^{+00}$

Radionuclide	a – Q _F tabulated in place of Q _A	Q _A or Q _F (TBq)	Q _B (TBq)	Q _C (TBq)	Q _D or Q _E (TBq)	A ₁ (TBq)	A ₂ (TBq)
Sn-117m		$7.1 \times 10^{+00}$	$1.0 \times 10^{+03}$	$2.2 \times 10^{+01}$	4.0×10^{-01}	$7 \times 10^{+00}$	4×10^{-01}
Sn-119m		$6.2 \times 10^{+01}$	$1.0 \times 10^{+03}$	$2.5 \times 10^{+01}$	$1.0 \times 10^{+03}$	$4 \times 10^{+01}$	$3 \times 10^{+01}$
Sn-121m		$1.4 \times 10^{+02}$	$1.0 \times 10^{+03}$	$1.1 \times 10^{+01}$	8.5×10^{-01}	$4 \times 10^{+01}$	9×10^{-01}
Sn-123		$1.6 \times 10^{+02}$	7.5×10^{-01}	$6.5 \times 10^{+00}$	6.1×10^{-01}	8×10^{-01}	6×10^{-01}
Sn-125		$3.6 \times 10^{+00}$	3.7×10^{-01}	$1.7 \times 10^{+01}$	6.2×10^{-01}	4×10^{-01}	4×10^{-01}
Sn-126		6.6×10^{-01}	5.9×10^{-01}	$1.9 \times 10^{+00}$	3.6×10^{-01}	6×10^{-01}	4×10^{-01}
Sr-82		9.7×10^{-01}	2.4×10^{-01}	$5.0 \times 10^{+00}$	5.9×10^{-01}	2×10^{-01}	2×10^{-01}
Sr-83		$1.3 \times 10^{+00}$	$2.7 \times 10^{+00}$	$1.4 \times 10^{+02}$	$2.2 \times 10^{+00}$	$1 \times 10^{+00}$	$1 \times 10^{+00}$
Sr-85		$2.1 \times 10^{+00}$	$1.0 \times 10^{+03}$	$6.5 \times 10^{+01}$	$8.5 \times 10^{+01}$	$2 \times 10^{+00}$	$2 \times 10^{+00}$
Sr-85m		$5.2 \times 10^{+00}$	$1.0 \times 10^{+03}$	$1.0 \times 10^{+03}$	$1.8 \times 10^{+01}$	$5 \times 10^{+00}$	$2 \times 10^{+00}$
Sr-87m		$3.3 \times 10^{+00}$	$1.0 \times 10^{+03}$	$1.0 \times 10^{+03}$	$3.3 \times 10^{+00}$	$3 \times 10^{+00}$	$3 \times 10^{+00}$
Sr-89		$1.0 \times 10^{+03}$	6.2×10^{-01}	$6.7 \times 10^{+00}$	6.1×10^{-01}	6×10^{-01}	6×10^{-01}
Sr-90		$1.0 \times 10^{+03}$	3.2×10^{-01}	3.3×10^{-01}	3.1×10^{-01}	3×10^{-01}	3×10^{-01}
Sr-91		$1.5 \times 10^{+00}$	3.0×10^{-01}	$1.2 \times 10^{+02}$	6.0×10^{-01}	3×10^{-01}	3×10^{-01}
Sr-92		$8.2 \times 10^{+00}$	$1.1 \times 10^{+00}$	$1.2 \times 10^{+02}$	3.1×10^{-01}	$1 \times 10^{+00}$	3×10^{-01}
T(H-3)		—	$1.0 \times 10^{+03}$	$1.0 \times 10^{+03}$	—	$4 \times 10^{+01}$	$4 \times 10^{+01}$
Ta-178 (2.2 h)		$1.1 \times 10^{+00}$	$1.0 \times 10^{+03}$	$7.2 \times 10^{+02}$	8.2×10^{-01}	$1 \times 10^{+00}$	8×10^{-01}
Ta-179		$3.1 \times 10^{+01}$	$1.0 \times 10^{+03}$	$9.6 \times 10^{+01}$	$1.0 \times 10^{+03}$	$3 \times 10^{+01}$	$3 \times 10^{+01}$
Ta-182		8.7×10^{-01}	$1.3 \times 10^{+01}$	$5.1 \times 10^{+00}$	5.4×10^{-01}	9×10^{-01}	5×10^{-01}
Tb-149		8.2×10^{-01}	$4.5 \times 10^{+01}$	1.2×10^{-13}	2.2×10^{-14}	8.0×10^{-01}	8.0×10^{-01}
Tb-157		$3.1 \times 10^{+02}$	$1.0 \times 10^{+03}$	$4.2 \times 10^{+01}$	$1.0 \times 10^{+03}$	$4 \times 10^{+01}$	$4 \times 10^{+01}$
Tb-158		$1.4 \times 10^{+00}$	$1.6 \times 10^{+02}$	$1.1 \times 10^{+00}$	$1.8 \times 10^{+00}$	$1 \times 10^{+00}$	$1 \times 10^{+00}$
Tb-160 Tb-161		9.8×10^{-01}	$2.3 \times 10^{+00}$	$7.6 \times 10^{+00}$	5.8×10^{-01}	$1 \times 10^{+00}$	6×10^{-01}
Tc-95m		$1.5 \times 10^{+00}$	$1.0 \times 10^{+03}$	$5.7 \times 10^{+01}$	$1.2 \times 10^{+01}$	$2 \times 10^{+00}$	$2 \times 10^{+00}$

Radionuclide	a – Q _F tabulated in place of Q _A	Q _A or Q _F (TBq)	Q _B (TBq)	Q _C (TBq)	Q _D or Q _E (TBq)	A ₁ (TBq)	A ₂ (TBq)
Tc-96		4.3×10^{-01}	$1.0 \times 10^{+03}$	$7.0 \times 10^{+01}$	$1.4 \times 10^{+02}$	4×10^{-01}	4×10^{-01}
Tc-96m		4.3×10^{-01}	$1.0 \times 10^{+03}$	$7.1 \times 10^{+01}$	$1.4 \times 10^{+02}$	4×10^{-01}	4×10^{-01}
Tc-97		$7.6 \times 10^{+01}$	$1.0 \times 10^{+03}$	Unlimited	Unlimited	Unlimited	Unlimited
Tc-97m		$8.6 \times 10^{+01}$	$1.0 \times 10^{+03}$	$1.6 \times 10^{+01}$	$1.4 \times 10^{+00}$	$4 \times 10^{+01}$	$1 \times 10^{+00}$
Tc-98		7.5×10^{-01}	$1.0 \times 10^{+03}$	Unlimited	6.8×10^{-01}	8×10^{-01}	7×10^{-01}
Tc-99		-	$1.0 \times 10^{+03}$	Unlimited	8.8×10^{-01}	$4 \times 10^{+01}$	9×10^{-01}
Tc-99m		$9.8 \times 10^{+00}$	$1.0 \times 10^{+03}$	$1.0 \times 10^{+03}$	$4.3 \times 10^{+00}$	$1 \times 10^{+01}$	$4 \times 10^{+00}$
Te-121		$1.8 \times 10^{+00}$	$1.0 \times 10^{+03}$	$1.3 \times 10^{+02}$	$1.0 \times 10^{+02}$	$2 \times 10^{+00}$	$2 \times 10^{+00}$
Te-121m		$5.1 \times 10^{+00}$	$1.0 \times 10^{+03}$	$1.2 \times 10^{+01}$	$2.5 \times 10^{+00}$	$5 \times 10^{+00}$	$3 \times 10^{+00}$
Te-123m		$7.7 \times 10^{+00}$	$1.0 \times 10^{+03}$	$1.3 \times 10^{+01}$	$1.2 \times 10^{+00}$	$8 \times 10^{+00}$	$1 \times 10^{+00}$
Te-125m		$2.0 \times 10^{+01}$	$1.0 \times 10^{+03}$	$1.5 \times 10^{+01}$	9.1×10^{-01}	$2 \times 10^{+01}$	9×10^{-01}
Te-127		$2.2 \times 10^{+02}$	$1.9 \times 10^{+01}$	$4.2 \times 10^{+02}$	6.6×10^{-01}	$2 \times 10^{+01}$	7×10^{-01}
Te-127m		$5.0 \times 10^{+01}$	$1.9 \times 10^{+01}$	$6.8 \times 10^{+00}$	5.0×10^{-01}	$2 \times 10^{+01}$	5×10^{-01}
Te-129		$1.7 \times 10^{+01}$	6.6×10^{-01}	$1.0 \times 10^{+03}$	6.1×10^{-01}	7×10^{-01}	6×10^{-01}
Te-129m		$1.3 \times 10^{+01}$	8.5×10^{-01}	$7.9 \times 10^{+00}$	4.4×10^{-01}	8×10^{-01}	4×10^{-01}
Te-131m		7.5×10^{-01}	$1.2 \times 10^{+00}$	$4.5 \times 10^{+01}$	4.9×10^{-01}	7×10^{-01}	5×10^{-01}
Te-132		4.9×10^{-01}	4.9×10^{-01}	$2.0 \times 10^{+01}$	4.2×10^{-01}	5×10^{-01}	4×10^{-01}
Th-227		$1.1 \times 10^{+01}$	$1.0 \times 10^{+03}$	5.2×10^{-03}	$4.7 \times 10^{+00}$	$1 \times 10^{+01}$	5×10^{-03}
Th-228		7.6×10^{-01}	5.3×10^{-01}	1.2×10^{-03}	2.7×10^{-01}	5×10^{-01}	1×10^{-03}
Th-229	a	$5.1 \times 10^{+00}$	$1.0 \times 10^{+03}$	5.1×10^{-04}	$1.8 \times 10^{+00}$	$5 \times 10^{+00}$	5×10^{-04}
Th-230	a	$1.2 \times 10^{+01}$	$1.0 \times 10^{+03}$	1.2×10^{-03}	Unlimited	$1 \times 10^{+01}$	1×10^{-03}
Th-231		$3.9 \times 10^{+01}$	$1.0 \times 10^{+03}$	1.6×10^{-02}	$1.2 \times 10^{+00}$	$4 \times 10^{+01}$	2×10^{-02}
Th-232		$1.2 \times 10^{+00}$	$1.0 \times 10^{+03}$	Unlimited	Unlimited	Unlimited	Unlimited
Th-234		$4.2 \times 10^{+01}$	3.0×10^{-01}	$6.8 \times 10^{+00}$	4.9×10^{-01}	3×10^{-01}	3×10^{-01}
Th(nat)		4.7×10^{-01}	2.7×10^{-01}	Unlimited	Unlimited	Unlimited	Unlimited
Ti-44		4.8×10^{-01}	6.1×10^{-01}	4.2×10^{-01}	6.2×10^{-01}	5×10^{-01}	4×10^{-01}

Radionuclide	a – Q _F tabulated in place of Q _A	Q _A or Q _F (TBq)	Q _B (TBq)	Q _C (TBq)	Q _D or Q _E (TBq)	A ₁ (TBq)	A ₂ (TBq)
Tl-200		8.5×10^{-01}	$1.0 \times 10^{+03}$	$3.6 \times 10^{+02}$	$7.1 \times 10^{+00}$	9×10^{-01}	9×10^{-01}
Tl-201		$1.2 \times 10^{+01}$	$1.0 \times 10^{+03}$	$1.0 \times 10^{+03}$	$4.0 \times 10^{+00}$	$1 \times 10^{+01}$	$4 \times 10^{+00}$
Tl-202		$2.3 \times 10^{+00}$	$1.0 \times 10^{+03}$	$2.5 \times 10^{+02}$	$1.6 \times 10^{+01}$	$2 \times 10^{+00}$	$2 \times 10^{+00}$
Tl-204		$9.9 \times 10^{+02}$	$9.6 \times 10^{+00}$	$1.1 \times 10^{+02}$	6.9×10^{-01}	$1 \times 10^{+01}$	7×10^{-01}
Tm-167		$7.4 \times 10^{+00}$	$1.0 \times 10^{+03}$	$4.5 \times 10^{+01}$	8.2×10^{-01}	$7 \times 10^{+00}$	8×10^{-01}
Tm-170		$2.0 \times 10^{+02}$	$2.6 \times 10^{+00}$	$7.6 \times 10^{+00}$	6.1×10^{-01}	$3 \times 10^{+00}$	6×10^{-01}
Tm-171		$1.0 \times 10^{+03}$	$1.0 \times 10^{+03}$	$3.8 \times 10^{+01}$	$1.0 \times 10^{+02}$	$4 \times 10^{+01}$	$4 \times 10^{+01}$
U-230 (F)		$5.2 \times 10^{+01}$	$1.0 \times 10^{+03}$	1.4×10^{-01}	$3.1 \times 10^{+00}$	$4 \times 10^{+01}$	1×10^{-01}
U-230 (M)	a	$3.8 \times 10^{+01}$	$1.0 \times 10^{+03}$	3.8×10^{-05}	$3.1 \times 10^{+00}$	$4 \times 10^{+01}$	4×10^{-05}
U-230 (S)	a	$3.3 \times 10^{+01}$	$1.0 \times 10^{+03}$	3.3×10^{-03}	$3.1 \times 10^{+00}$	$3 \times 10^{+01}$	3×10^{-03}
U-232 (F)	a	$1.4 \times 10^{+02}$	$1.0 \times 10^{+03}$	1.4×10^{-02}	$1.8 \times 10^{+02}$	$4 \times 10^{+01}$	1×10^{-02}
U-232 (M)	a	$7.1 \times 10^{+01}$	$1.0 \times 10^{+03}$	7.1×10^{-03}	$1.8 \times 10^{+02}$	$4 \times 10^{+01}$	7×10^{-03}
U-232 (S)	a	$1.4 \times 10^{+01}$	$1.0 \times 10^{+03}$	1.4×10^{-03}	$1.8 \times 10^{+02}$	$1 \times 10^{+01}$	1×10^{-03}
U-233 (F)		$8.0 \times 10^{+02}$	$1.0 \times 10^{+03}$	8.8×10^{-02}	Unlimited	$4 \times 10^{+01}$	9×10^{-02}
U-233 (M)	a	$1.6 \times 10^{+02}$	$1.0 \times 10^{+03}$	1.6×10^{-02}	Unlimited	$4 \times 10^{+01}$	2×10^{-02}
U-233 (S)	a	$5.7 \times 10^{+01}$	$1.0 \times 10^{+03}$	5.7×10^{-05}	Unlimited	$4 \times 10^{+01}$	6×10^{-05}
U-234 (F)		$6.0 \times 10^{+02}$	$1.0 \times 10^{+03}$	9.1×10^{-02}	Unlimited	$4 \times 10^{+01}$	9×10^{-02}
U-234 (M)	a	$1.6 \times 10^{+02}$	$1.0 \times 10^{+03}$	1.6×10^{-02}	Unlimited	$4 \times 10^{+01}$	2×10^{-02}
U-234 (S)	a	$5.9 \times 10^{+01}$	$1.0 \times 10^{+03}$	5.9×10^{-03}	Unlimited	$4 \times 10^{+01}$	6×10^{-03}
U-235 (F)		$6.4 \times 10^{+00}$	$1.0 \times 10^{+03}$	Unlimited	Unlimited	Unlimited	Unlimited
U-235 (M)		$6.4 \times 10^{+00}$	$1.0 \times 10^{+03}$	Unlimited	Unlimited	Unlimited	Unlimited
U-235 (S)		$6.4 \times 10^{+00}$	$1.0 \times 10^{+03}$	Unlimited	Unlimited	Unlimited	Unlimited
U-236 (F)		$6.6 \times 10^{+02}$	$1.0 \times 10^{+03}$	Unlimited	Unlimited	Unlimited	Unlimited
U-236 (M)	a	$1.7 \times 10^{+02}$	$1.0 \times 10^{+03}$	1.7×10^{-02}	Unlimited	$4 \times 10^{+01}$	2×10^{-02}
U-236 (S)	a	$6.3 \times 10^{+01}$	$1.0 \times 10^{+03}$	6.3×10^{-05}	Unlimited	$4 \times 10^{+01}$	6×10^{-05}
U-238 (F)		$7.5 \times 10^{+02}$	$1.0 \times 10^{+03}$	Unlimited	Unlimited	Unlimited	Unlimited
U-238 (M)	a	$1.9 \times 10^{+02}$	$1.0 \times 10^{+03}$	Unlimited	Unlimited	Unlimited	Unlimited

Radionuclide	a – Q _F tabulated in place of Q _A	Q _A or Q _F (TBq)	Q _B (TBq)	Q _C (TBq)	Q _D or Q _E (TBq)	A ₁ (TBq)	A ₂ (TBq)
U-238 (S)	a	$6.8 \times 10^{+01}$	$1.0 \times 10^{+03}$	Unlimited	Unlimited	Unlimited	Unlimited
U (nat)		6.4e-01	1.3×10^{-01}	Unlimited	Unlimited	Unlimited	Unlimited
U (<20% enr.)		—	—	—	—	Unlimited	Unlimited
U(dep)		$4.7 \times 10^{+01}$	3.3×10^{-01}	Unlimited	Unlimited	Unlimited	Unlimited
V-48		3.8×10^{-01}	$3.0 \times 10^{+00}$	$2.2 \times 10^{+01}$	$1.1 \times 10^{+00}$	4×10^{-01}	4×10^{-01}
V-49		$1.0 \times 10^{+03}$	$1.0 \times 10^{+03}$	$1.0 \times 10^{+03}$	$1.0 \times 10^{+03}$	$4 \times 10^{+01}$	$4 \times 10^{+01}$
W-178		$8.8 \times 10^{+00}$	$1.0 \times 10^{+03}$	$6.4 \times 10^{+02}$	$4.6 \times 10^{+00}$	$9 \times 10^{+00}$	$5 \times 10^{+00}$
W-181		$2.6 \times 10^{+01}$	$1.0 \times 10^{+03}$	$1.0 \times 10^{+03}$	$5.3 \times 10^{+02}$	$3 \times 10^{+01}$	$3 \times 10^{+01}$
W-185		$1.0 \times 10^{+03}$	$1.0 \times 10^{+03}$	$3.6 \times 10^{+02}$	8.1×10^{-01}	$4 \times 10^{+01}$	8×10^{-01}
W-187		$2.2 \times 10^{+00}$	$2.1 \times 10^{+00}$	$2.5 \times 10^{+02}$	6.2×10^{-01}	$2 \times 10^{+00}$	6×10^{-01}
W-188		$2.0 \times 10^{+01}$	3.7×10^{-01}	$4.4 \times 10^{+01}$	3.5×10^{-01}	4×10^{-01}	3×10^{-01}
Xe-122		$1.1 \times 10^{+00}$	4.0×10^{-01}	—	$8.8 \times 10^{+00}$	4×10^{-01}	4×10^{-01}
Xe-123		$1.8 \times 10^{+00}$	$1.0 \times 10^{+01}$	—	6.8×10^{-01}	$2 \times 10^{+00}$	7×10^{-01}
Xe-127		$3.9 \times 10^{+00}$	$1.0 \times 10^{+03}$	—	$1.7 \times 10^{+00}$	$4 \times 10^{+00}$	$2 \times 10^{+00}$
Xe-131m		$3.8 \times 10^{+01}$	$1.0 \times 10^{+03}$	—	$4.0 \times 10^{+01}$	$4 \times 10^{+01}$	$4 \times 10^{+01}$
Xe-133		$2.1 \times 10^{+01}$	$1.0 \times 10^{+03}$	—	$1.5 \times 10^{+01}$	$2 \times 10^{+01}$	$1 \times 10^{+01}$
Xe-135		$4.5 \times 10^{+00}$	$3.5 \times 10^{+00}$	—	$1.8 \times 10^{+00}$	$3 \times 10^{+00}$	$2 \times 10^{+00}$
Y-87		$1.4 \times 10^{+00}$	$1.0 \times 10^{+03}$	$1.2 \times 10^{+02}$	$3.2 \times 10^{+00}$	$1 \times 10^{+00}$	$1 \times 10^{+00}$
Y-88		4.3×10^{-01}	$1.0 \times 10^{+03}$	$1.2 \times 10^{+01}$	$2.2 \times 10^{+02}$	4×10^{-01}	4×10^{-01}
Y-90		$1.0 \times 10^{+03}$	3.2×10^{-01}	$3.3 \times 10^{+01}$	5.9×10^{-01}	3×10^{-01}	3×10^{-01}
Y-91		$3.1 \times 10^{+02}$	5.9×10^{-01}	$6.0 \times 10^{+00}$	6.1×10^{-01}	6×10^{-01}	6×10^{-01}
Y-91m		$2.0 \times 10^{+00}$	$1.0 \times 10^{+03}$	$1.0 \times 10^{+03}$	$1.2 \times 10^{+01}$	$2 \times 10^{+00}$	$2 \times 10^{+00}$
Y-92		$4.4 \times 10^{+00}$	2.2×10^{-01}	$2.5 \times 10^{+02}$	5.6×10^{-01}	2×10^{-01}	2×10^{-01}
Y-93		$1.3 \times 10^{+01}$	2.6×10^{-01}	$1.2 \times 10^{+02}$	5.8×10^{-01}	3×10^{-01}	3×10^{-01}
Yb-169		$3.5 \times 10^{+00}$	$1.0 \times 10^{+03}$	$1.8 \times 10^{+01}$	$1.0 \times 10^{+00}$	$4 \times 10^{+00}$	$1 \times 10^{+00}$

Radionuclide	a – Q _F tabulated in place of Q _A	Q _A or Q _F (TBq)	Q _B (TBq)	Q _C (TBq)	Q _D or Q _E (TBq)	A ₁ (TBq)	A ₂ (TBq)
Yb-175		$2.7 \times 10^{+01}$	$1.0 \times 10^{+03}$	$7.1 \times 10^{+01}$	$4.2 \times 10^{+01}$	$2 \times 10^{+00}$	$2 \times 10^{+00}$
Zn-69		$1.0 \times 10^{+03}$	$3.2 \times 10^{+00}$	$1.0 \times 10^{+03}$	6.2×10^{-01}	$3 \times 10^{+00}$	6×10^{-01}
Zn-69m		$3.4 \times 10^{+00}$	$4.0 \times 10^{+00}$	$1.7 \times 10^{+02}$	5.9×10^{-01}	$3 \times 10^{+00}$	6×10^{-01}
Zr-88		$2.6 \times 10^{+00}$	$1.0 \times 10^{+03}$	$1.4 \times 10^{+01}$	$2.1 \times 10^{+01}$	$3 \times 10^{+00}$	$3 \times 10^{+00}$
Zr-93		—	$1.0 \times 10^{+03}$	Unlimited	Unlimited	Unlimited	Unlimited
Zr-95		$1.8 \times 10^{+00}$	$4.5 \times 10^{+02}$	$9.1 \times 10^{+00}$	8.5×10^{-01}	$2 \times 10^{+00}$	8×10^{-01}
Zr-97		9.2×10^{-01}	3.7×10^{-01}	$5.0 \times 10^{+01}$	5.6×10^{-01}	4×10^{-01}	4×10^{-01}

Multiple exposure pathways

I.79. Following the 1985 Edition of the Transport Regulations, the application of the Q system treats the derivation of each Q value, and hence each potential exposure pathway, separately. In general, this will result in compliance with the dosimetric criteria defined earlier, provided that the doses incurred by persons exposed near a damaged package are dominated by one pathway. However, if two or more Q values closely approach each other, this will not necessarily be the case. For example, in the case of a radionuclide transported as a special form radioactive material for which $Q_A \approx Q_B$, the effective dose and the equivalent skin dose to an exposed person could approach 50 mSv and 0.5 Sv, respectively, based on the Q system models. Examination of Table I.2 shows that this consideration applies only to a relatively small number of radionuclides, and for this reason the independent treatment of exposure pathways is retained within the Q system.

Mixtures of radionuclides

I.80. It is necessary to consider the package contents limits for mixtures of radionuclides, including the special case of mixed fission products. For mixtures whose identities and activities are known, it is necessary to show that:

$$\sum_i \frac{B(i)}{A_1(i)} + \sum_j \frac{C(j)}{A_2(j)} \leq 1 \quad (\text{I.23})$$

where

B(i) is the activity of radionuclide i as special form radioactive material;

$A_1(i)$ is the A_1 value for radionuclide i ;

$C(j)$ is the activity of radionuclide j as non-special form radioactive material;

$A_2(j)$ is the A_2 value for radionuclide j .

I.81. Alternatively, values for mixtures may be determined as follows:

$$X_m \text{ for mixture} = \frac{1}{\sum_i \frac{f(i)}{X(i)}} \quad (\text{I.24})$$

where

$f(i)$ is the fraction of activity of radionuclide i in the mixture;

$X(i)$ is the appropriate value of A_1 or A_2 for the radionuclide;

X_m is the derived value of A_1 or A_2 , for the mixture.

DECAY CHAINS USED IN THE Q SYSTEM

I.82. The various decay chains that were used in developing A_1 and A_2 values with the Q system, as described in paras I.55–I.57, are listed in footnote (a) of Table 2 of the Transport Regulations.

CONCLUSIONS

I.83. The Q system described here represents an updating of the original A_1/A_2 system used in the 1985 Edition of the Transport Regulations for the determination of Type A package contents and other limits. It incorporates the recommendations of the ICRP Publication 103 [I.8], and by explicitly identifying the dosimetric considerations underlying the derivation of these limits, provides a firm and defensible basis for the Transport Regulations.

I.84. The Q system now has the following features:

- (a) The radiological criteria and exposure assumptions used in the 1985 Edition of the Transport Regulations have been reviewed and retained.
- (b) The effective dose quantity of ICRP Publication 103 [I.8] has been adopted.
- (c) The evaluation of the external dose from photons and beta particles has been rigorously revised.
- (d) The evaluation of intakes by inhalation is now in terms of the effective dose and is based on the dose coefficients from the GSR Part 3 [I. 9].

Further review, based upon future developments, is not precluded.

REFERENCES TO APPENDIX I

- [I.1] INTERNATIONAL ATOMIC ENERGY AGENCY, International Studies on Certain Aspects of the Safe Transport of Radioactive Materials, 1980–1985, IAEA-TECDOC-375, IAEA, Vienna (1986).
- [I.2] GOLDFINCH, E.P., MACDONALD, H.F., Dosimetric aspects of permitted activity leakage rates for Type B packages for the transport of radioactive materials, *Radiat. Prot. Dosim.* **2** (1982) 75.
- [I.3] MACDONALD, H.F., GOLDFINCH, E.P., “An alternative approach to the A₁/A₂ system for determining package contents limits and permitted releases of radioactivity from transport packages”, *Packaging and Transportation of Radioactive Materials, PATRAM 80* (Proc. Int. Symp. Berlin, 1980), Bundesanstalt für Materialprüfung, Berlin (1980).
- [I.4] MACDONALD, H.F., GOLDFINCH, E.P., Dosimetric aspects of Type A package contents limits under the IAEA Regulations, *Radiat. Prot. Dosim.* **1** (1981) 29–42.
- [I.5] MACDONALD, H.F., GOLDFINCH, E.P., Dosimetric aspects of Type A package contents limits under the IAEA Regulations for the Safe Transport of Radioactive Materials — Supplementary list of isotopes, *Radiat. Prot. Dosim.* **1** (1981) 199–202.
- [I.6] GOLDFINCH, E.P., MACDONALD, H.F., “A review of some radiological aspects of the IAEA Regulations for the Safe Transport of Radioactive Materials”, *Radiological Protection — Advances in Theory and Practice* (Proc. Symp. Inverness, 1982), Society for Radiological Protection, Berkeley, UK (1982).
- [I.7] GOLDFINCH, E.P., MACDONALD, H.F., “IAEA regulations for the safe transport of radioactive materials: Revised A₁ and A₂ values”, *Packaging and Transportation of Radioactive Materials, PATRAM 83* (Proc. Int. Symp. New Orleans, 1983), Oak Ridge Natl Lab., TN (1983).
- [I.8] INTERNATIONAL COMMISSION ON RADIOLOGICAL PROTECTION, The 2007 Recommendations of the International Commission on Radiological Protection, ICRP publication 103, *Ann. ICRP* **37** (2-4), 2007.
- [I. 9] EUROPEAN COMMISSION, FOOD AND AGRICULTURE ORGANIZATION OF THE UNITED NATIONS, INTERNATIONAL ATOMIC ENERGY AGENCY, INTERNATIONAL LABOUR ORGANIZATION, OECD NUCLEAR ENERGY AGENCY, PAN AMERICAN HEALTH ORGANIZATION, UNITED NATIONS ENVIRONMENT PROGRAMME, WORLD HEALTH ORGANIZATION, Radiation Protection and Safety of Radiation Sources: International Basic Safety Standards, IAEA Safety Standards Series No. GSR Part 3, IAEA, Vienna (2014).

- [I.10] INTERNATIONAL ATOMIC ENERGY AGENCY, IAEA Safety Glossary: Terminology Used in Nuclear Safety and Radiation Protection, 2018 Edition, IAEA, Vienna 2018.
- [I.11] INTERNATIONAL COMMISSION ON RADIOLOGICAL PROTECTION, Conversion Coefficients for Radiological Protection Quantities for External Radiation Exposures, ICRP publication 116, Ann. ICRP 40(2-5), 2010.
- [I.12] INTERNATIONAL COMMISSION ON RADIOLOGICAL PROTECTION, Task Group on Dose Calculations — Energy and Intensity Data for Emissions Accompanying Radionuclide Transformations, Publication 38, Pergamon Press, Oxford and New York (1984).
- [I.13] INTERNATIONAL COMMISSION ON RADIOLOGICAL PROTECTION, Nuclear Decay Data for Dosimetric Calculations, ICRP Publication 107, Ann. ICRP 38, 2008.
- [I.14] INTERNATIONAL COMMISSION ON RADIOLOGICAL PROTECTION, Data for Use in Protection against External Radiation, Publication 51, Pergamon Press, Oxford and New York (1987).
- [I.15] ECKERMAN, K.F., WESTFALL, R.J., RYMAN, J.C., CRISTY, M., Nuclear Decay Data Files of the Dosimetry Research Group, Rep. ORNL/TM-12350, Oak Ridge Natl Lab., TN (1993).
- [I.16] CROSS, W.G., ING, H., FREEDMAN, N.O., WONG, P.J., Table of beta-ray dose distributions in an infinite water medium, Health Phys. **63** (1992).
- [I.17] CROSS, W.G., ING, H., FREEDMAN, N.O., MAINVILLE, J., Tables of Beta-Ray Dose Distributions in Water, Air, and Other Media, Rep. AECL-7617, Atomic Energy of Canada Ltd, Chalk River, ON (1982).
- [I.18] INTERNATIONAL COMMISSION ON RADIOLOGICAL PROTECTION, Recommendations of the International Commission on Radiological Protection, Publication 26, Pergamon Press, Oxford and New York (1977).
- [I.19] CROSS, W.G., ING, H., FREEDMAN, N.O., MAINVILLE, J., Tables of Beta-Ray Dose Distributions in Water, Air, and Other Media, Rep. AECL-2793, Atomic Energy of Canada Ltd, Chalk River, ON (1967).
- [I.20] BAILEY, M.R., BETA: A Computer Program for Calculating Beta Dose Rates from Point and Plane Sources, Rep. RD/B/N2763, Central Electricity Generating Board, London (1973).
- [I.21] INTERNATIONAL COMMISSION ON RADIOLOGICAL PROTECTION, Limits for Intakes of Radionuclides by Workers, Publication 30, Parts 1–3, Pergamon Press, Oxford and New York (1980).

- [I.22] LOHMANN, D.H., Transport of radioactive materials: A review of damage to packages from the radiochemical centre during transport, Packaging and Transportation of Radioactive Materials, PATRAM 80 (Proc. Int. Symp. Berlin, 1980), Bundesanstalt für Materialprüfung, Berlin (1980).
- [I.23] HADJANTONION, A., ARMIRIOTIS, J., ZANNOS, A., The performance of Type A packaging under air crash and fire accident conditions, *ibid.*
- [I.24] TAYLOR, C.B.G., Radioisotope packages in crush and fire, *ibid.*
- [I.25] STEWART, K., Principal Characteristics of Radioactive Contaminants Which May Appear in the Atmosphere, Progress in Nuclear Energy, Series 12, Health Physics, Vol. 2, Pergamon Press, Oxford and New York (1969).
- [I.26] WEHNER, G., The importance of reportable events in public acceptance, Packaging and Transportation of Radioactive Materials, PATRAM 83 (Proc. Int. Symp. New Orleans, 1983), Oak Ridge Natl Lab., TN (1983).
- [I.27] BRYANT, P.M., Methods of Estimation of the Dispersion of Windborne Material and Data to Assist in their Application, Rep. AHSB(RP)R42, United Kingdom Atomic Energy Authority, Berkeley, UK (1964).
- [I.28] DUNSTER, H.J., Maximum Permissible Levels of Skin Contamination, Rep. AHSB (RP)R78, United Kingdom Atomic Energy Authority, Harwell (1967).
- [I.29] CROSS, W.G., FREEDMAN, N.O., WONG, P.Y., Beta ray dose distributions from skin contamination, *Radiat. Prot. Dosim.* **40** 3 (1992) 149–168.
- [I.30] UNITED STATES ENVIRONMENTAL PROTECTION AGENCY, External Exposure to Radionuclides in Air, Water and Soil, Federal Guidance Rep. No. 12, USEPA, Washington, DC (1993).
- [I.31] INTERNATIONAL COMMISSION ON RADIOLOGICAL PROTECTION, Data for Protection against Ionizing Radiation from External Sources: Supplement to ICRP Publication 15, Publication 21, Pergamon Press, Oxford and New York (1973).
- [I.32] ECKERMAN, K.F., RAWL, R., HUGHES, J.S., BOLOGNA, L., Type A package limits of spontaneous fission radionuclides, Packaging and Transportation of Radioactive Materials, PATRAM 2001 (Proc. Int. Symp. Chicago, 2001), Department of Energy, Washington, DC (2001).
- [I.33] INTERNATIONAL COMMISSION ON RADIOLOGICAL PROTECTION, Conversion Coefficients for use in Radiological Protection against External Radiation, Publication 74, Pergamon Press, Oxford and New York (1996).
- [I.34] FAIRBAIRN, A., MORLEY, F., KOLB, W., The classification of radionuclides for transport purposes, The Safe Transport of Radioactive Materials (GIBSON, R., Ed.), Pergamon Press, Oxford and New York (1966) 44–46.

- [I.35] AMERICAN SOCIETY FOR TESTING AND MATERIALS, Standard Specification for Uranium Hexafluoride Enriched to Less than 5% U-235, ASTM C996-90, ASTM, Philadelphia, PA (1991).
- [I.36] MACDONALD, H.F., Radiological Limits in the Transport of Irradiated Nuclear Fuels, Rep. TPRD/B/0388/N84, Central Electricity Generating Board, Berkeley, UK (1984).
- [I.37] MACDONALD, H.F., Individual and collective doses arising in the transport of irradiated nuclear fuels, Packaging and Transportation of Radioactive Materials, PATRAM 80 (Proc. Int. Symp. Berlin, 1980), Bundesanstalt für Materialprüfung, Berlin (1980).

Appendix II

HALF-LIFE AND SPECIFIC ACTIVITY OF RADIONUCLIDES, DOSE AND DOSE RATE COEFFICIENTS OF RADIONUCLIDES AND SPECIFIC ACTIVITY

II.1. Table II.1 provides a listing of the half-life and the specific activity of each radionuclide calculated using the equation shown in para. 240.2 (see Ref. [II.1]). As specified in para. 240 of the Transport Regulations, the specific activity of a radionuclide is the “activity per unit mass of that nuclide”, whereas the specific activity of a material “shall mean the activity per unit mass or volume of the material in which the radionuclides are essentially uniformly distributed”. The specific activity values listed in Table II.1 relate to the radionuclide and not to the material.

II.2. Table II.2 provides a listing of the dose and dose rate coefficients of each radionuclide.

II.3. Table II.3 provides the specific activity of uranium for various levels of enrichment. These figures for uranium include the activity of U-234, which is concentrated during the enrichment process.

TABLE II.1. HALF-LIFE AND SPECIFIC ACTIVITY OF RADIONUCLIDES

Radionuclide	Element and atomic number	Half-life		Specific activity (Bq/g)
		T _{1/2} (a, d, h, min)	T _{1/2} (s)	
Ac-225	Actinium (89)	10 d	8.640×10^5	2.150×10^{15}
Ac-227		21.773 a	6.866×10^8	2.682×10^{12}
Ac-228		6.13 h	2.207×10^4	8.308×10^{16}
Ag-105	Silver (47)	41 d	3.542×10^6	1.124×10^{15}
Ag-108m		127 a	4.005×10^9	9.664×10^{11}
Ag-110m		249.9 d	2.159×10^7	1.760×10^{14}
Ag-111		7.45 d	6.437×10^5	5.850×10^{15}
Al-26	Aluminium (13)	7.16×10^5 a	2.258×10^{13}	7.120×10^8

Radionuclide	Element and atomic number	Half-life		Specific activity (Bq/g)
		T _{1/2} (a, d, h, min)	T _{1/2} (s)	
Am-241	Americium (95)	432.2 a	1.363 × 10 ¹⁰	1.273 × 10 ¹¹
Am-242m		152 a	4.793 × 10 ⁹	3.603 × 10 ¹¹
Am-243		7380 a	2.327 × 10 ¹¹	7.391 × 10 ⁹
Ar-37	Argon (18)	35.02 d	3.026 × 10 ⁶	3.734 × 10 ¹⁵
Ar-39		269 a	8.483 × 10 ⁹	1.263 × 10 ¹²
Ar-41		1.827 h	6.577 × 10 ³	1.550 × 10 ¹⁸
As-72	Arsenic (33)	26 h	9.360 × 10 ⁴	6.203 × 10 ¹⁶
As-73		80.3 d	6.938 × 10 ⁶	8.253 × 10 ¹⁴
As-74		17.76 d	1.534 × 10 ⁶	3.681 × 10 ¹⁵
As-76		26.32 h	9.475 × 10 ⁴	5.805 × 10 ¹⁶
As-77		38.8 h	1.397 × 10 ⁵	3.886 × 10 ¹⁶
At-211	Astatine (85)	7.214 h	2.597 × 10 ⁴	7.628 × 10 ¹⁶
Au-193	Gold (79)	17.65 h	6.354 × 10 ⁴	3.409 × 10 ¹⁶
Au-194		39.5 h	1.422 × 10 ⁵	1.515 × 10 ¹⁶
Au-195		183 d	1.581 × 10 ⁷	1.356 × 10 ¹⁴
Au-198		2.696 d	2.329 × 10 ⁵	9.063 × 10 ¹⁵
Au-199		3.139 d	2.712 × 10 ⁵	7.745 × 10 ¹⁵
Ba-131	Barium (56)	11.8 d	1.020 × 10 ⁶	3.130 × 10 ¹⁵
Ba-133		10.74 a	3.387 × 10 ⁸	9.279 × 10 ¹²
Ba-133m		38.9 h	1.400 × 10 ⁵	2.244 × 10 ¹⁶

Radionuclide	Element and atomic number	Half-life		Specific activity (Bq/g)
		T _{1/2} (a, d, h, min)	T _{1/2} (s)	
Ba-135m		28.7 h	1.033×10^5	2.995×10^{16}
Ba-140		12.74 d	1.101×10^6	2.712×10^{15}
Be-7	Beryllium (4)	53.3 d	4.605×10^6	1.297×10^{16}
Be-10		1.6×10^6 a	5.046×10^{13}	8.284×10^8
Bi-205	Bismuth (83)	15.31 d	1.323×10^6	1.541×10^{15}
Bi-206		6.243 d	5.394×10^5	3.762×10^{15}
Bi-207		38 a	1.198×10^9	1.685×10^{12}
Bi-210		5.012 d	4.330×10^5	4.597×10^{15}
Bi-210m		3.0×10^6 a	9.461×10^{13}	2.104×10^7
Bi-212		60.55 min	3.633×10^3	5.427×10^{17}
Bk-247	Berkelium (97)	1380 a	4.352×10^{10}	3.889×10^{10}
Bk-249		320 d	2.765×10^7	6.072×10^{13}
Br-76	Bromine (35)	16.2 h	5.832×10^4	9.431×10^{16}
Br-77		56 h	2.016×10^5	2.693×10^{16}
Br-82		35.3 h	1.271×10^5	4.011×10^{16}
C-11	Carbon (6)	20.38 min	1.223×10^3	3.108×10^{19}
C-14		5730 a	1.807×10^{11}	1.652×10^{11}
Ca-41	Calcium (20)	1.4×10^5 a	4.415×10^{12}	2.309×10^9
Ca-45		163 d	1.408×10^7	6.596×10^{14}

Radionuclide	Element and atomic number	Half-life		Specific activity (Bq/g)
		T _{1/2} (a, d, h, min)	T _{1/2} (s)	
Ca-47		4.53 d	3.914×10^5	2.272×10^{16}
Cd-109	Cadmium (48)	464 d	4.009×10^7	9.566×10^{13}
Cd-113m		13.6 a	4.289×10^8	8.625×10^{12}
Cd-115		53.46 h	1.925×10^5	1.889×10^{16}
Cd-115m		44.6 d	3.853×10^6	9.433×10^{14}
Ce-139	Cerium (58)	137.66 d	1.189×10^7	2.528×10^{14}
Ce-141		32.501 d	2.808×10^6	1.056×10^{15}
Ce-143		33 h	1.188×10^5	2.461×10^{16}
Ce-144		284.3 d	2.456×10^7	1.182×10^{14}
Cf-248	Californium (98)	333.5 d	2.881×10^7	5.849×10^{13}
Cf-249		350.6 a	1.106×10^{10}	1.518×10^{11}
Cf-250		13.08 a	4.125×10^8	4.053×10^{12}
Cf-251		898 a	2.832×10^{10}	5.881×10^{10}
Cf-252		2.638 a	8.319×10^7	1.994×10^{13}
Cf-253		17.81 d	1.539×10^6	1.074×10^{15}
Cf-254		60.5 d	5.227×10^6	3.148×10^{14}
Cl-36		Chlorine (17)	3.01×10^5 a	9.492×10^{12}
Cl-38	37.21 min		2.233×10^3	4.927×10^{18}
Cm-240	Curium (96)	27 d	2.333×10^6	7.466×10^{14}
Cm-241		32.8 d	2.834×10^6	6.120×10^{14}

Radionuclide	Element and atomic number	Half-life		Specific activity (Bq/g)
		T _{1/2} (a, d, h, min)	T _{1/2} (s)	
Cm-242		162.8 d	1.407×10^7	1.228×10^{14}
Cm-243		28.5 a	8.988×10^8	1.914×10^{12}
Cm-244		18.11 a	5.711×10^8	3.000×10^{12}
Cm-245		8500 a	2.681×10^{11}	6.365×10^9
Cm-246		4730 a	1.492×10^{11}	1.139×10^{10}
Cm-247		1.56×10^7 a	4.920×10^{14}	3.440×10^6
Cm-248		3.39×10^5 a	1.069×10^{13}	1.577×10^8
Co-55	Cobalt (27)	17.54 h	6.314×10^4	1.204×10^{17}
Co-56		78.76 d	6.805×10^6	1.097×10^{15}
Co-57		270.9 d	2.341×10^7	3.133×10^{14}
Co-58		70.8 d	6.117×10^6	1.178×10^{15}
Co-58m		9.15 h	3.294×10^4	2.188×10^{17}
Co-60		5.271 a	1.662×10^8	4.191×10^{13}
Cr-51	Chromium (24)	27.704 d	2.394×10^6	3.424×10^{15}
Cs-129	Caesium (55)	32.06 h	1.154×10^5	2.808×10^{16}
Cs-131		9.69 d	8.372×10^5	3.811×10^{15}
Cs-132		6.475 d	5.594×10^5	5.660×10^{15}
Cs-134		2.062 a	6.503×10^7	4.797×10^{13}
Cs-134m		2.9 h	1.044×10^4	2.988×10^{17}
Cs-135		2.3×10^6 a	7.253×10^{13}	4.269×10^7
Cs-136		13.1 d	1.132×10^6	2.716×10^{15}
Cs-137		30 a	9.461×10^8	3.225×10^{12}

Radionuclide	Element and atomic number	Half-life		Specific activity (Bq/g)	
		T _{1/2} (a, d, h, min)	T _{1/2} (s)		
Cu-64	Copper (29)	12.701 h	4.572 × 10 ⁴	1.428 × 10 ¹⁷	
Cu-67		61.86 h	2.227 × 10 ⁵	2.801 × 10 ¹⁶	
Dy-159	Dysprosium (66)	144.4 d	1.248 × 10 ⁷	2.107 × 10 ¹⁴	
Dy-165		2.334 h	8.402 × 10 ³	3.015 × 10 ¹⁷	
Dy-166		81.6 h	2.938 × 10 ⁵	8.572 × 10 ¹⁵	
Er-169	Erbium (68)	9.3 d	8.035 × 10 ⁵	3.078 × 10 ¹⁵	
Er-171		7.52 h	2.707 × 10 ⁴	9.029 × 10 ¹⁶	
Eu-147	Europium (63)	24 d	2.074 × 10 ⁶	1.371 × 10 ¹⁵	
Eu-148		54.5 d	4.709 × 10 ⁶	5.998 × 10 ¹⁴	
Eu-149		93.1 d	8.044 × 10 ⁶	3.488 × 10 ¹⁴	
Eu-150(short lived)		12.62 h	4.543 × 10 ⁴	6.134 × 10 ¹⁶	
Eu-150(long lived)		34.2 a	1.079 × 10 ⁹	2.584 × 10 ¹²	
Eu-152		13.33 a	4.204 × 10 ⁸	6.542 × 10 ¹²	
Eu-152m		9.32 h	3.355 × 10 ⁴	8.196 × 10 ¹⁶	
Eu-154		8.8 a	2.775 × 10 ⁸	9.781 × 10 ¹²	
Eu-155		4.96 a	1.564 × 10 ⁸	1.724 × 10 ¹³	
Eu-156		15.19 d	1.312 × 10 ⁶	2.042 × 10 ¹⁵	
F-18		Fluorine (9)	109.77 min	6.586 × 10 ³	3.526 × 10 ¹⁸
Fe-52			Iron (26)	8.275 h	2.979 × 10 ⁴

Radionuclide	Element and atomic number	Half-life		Specific activity (Bq/g)
		T _{1/2} (a, d, h, min)	T _{1/2} (s)	
Fe-55		2.7 a	8.515×10^7	8.926×10^{13}
Fe-59		44.529 d	3.847×10^6	1.841×10^{15}
Fe-60		1.0×10^5 a	3.154×10^{12}	2.209×10^9
Ga-67	Gallium (31)	78.26 h	2.817×10^5	2.214×10^{16}
Ga-68		68 min	4.080×10^3	1.507×10^{18}
Ga-72		14.1 h	5.076×10^4	1.144×10^{17}
Gd-146	Gadolinium (64)	48.3 d	4.173×10^6	6.861×10^{14}
Gd-148		93 a	2.933×10^9	9.630×10^{11}
Gd-153		242 d	2.091×10^7	1.307×10^{14}
Gd-159		18.56 h	6.682×10^4	3.935×10^{16}
Ge-68	Germanium (32)	288 d	2.488×10^7	2.470×10^{14}
Ge-69		39.05 h	1.406×10^5	4.307×10^{16}
Ge-71		11.8 d	1.020×10^6	5.775×10^{15}
Ge-77		11.3 h	4.068×10^4	1.334×10^{17}
Hf-172	Hafnium (72)	1.87 a	5.897×10^7	4.121×10^{13}
Hf-175		70 d	6.048×10^6	3.949×10^{14}
Hf-181		42.4 d	3.663×10^6	6.304×10^{14}
Hf-182		9.0×10^6 a	2.838×10^{14}	8.092×10^6
Hg-194	Mercury (80)	260 a	8.199×10^9	2.628×10^{11}
Hg-195m		41.6 h	1.498×10^5	1.431×10^{16}

Radionuclide	Element and atomic number	Half-life		Specific activity (Bq/g)
		T _{1/2} (a, d, h, min)	T _{1/2} (s)	
Hg-197		64.1 h	2.308×10^5	9.195×10^{15}
Hg-197m		23.8 h	8.568×10^4	2.476×10^{16}
Hg-203		46.6 d	4.026×10^6	5.114×10^{14}
Ho-166	Holmium (67)	26.8 h	9.648×10^4	2.610×10^{16}
Ho-166m		1200 a	3.784×10^{10}	6.655×10^{10}
I-123	Iodine (53)	13.2 h	4.752×10^4	7.151×10^{16}
I-124		4.18 d	3.612×10^5	9.334×10^{15}
I-125		60.14 d	5.196×10^6	6.436×10^{14}
I-126		13.02 d	1.125×10^6	2.949×10^{15}
I-129		1.57×10^7 a	4.951×10^{14}	6.545×10^6
I-131		8.04 d	6.947×10^5	4.593×10^{15}
I-132		2.3 h	8.280×10^3	3.824×10^{17}
I-133		20.8 h	7.488×10^4	4.197×10^{16}
I-134		52.6 min	3.156×10^3	9.884×10^{17}
I-135		6.61 h	2.380×10^4	1.301×10^{17}
In-111	Indium (49)	2.83 d	2.445×10^5	1.540×10^{16}
In-113m		1.658 h	5.969×10^3	6.197×10^{17}
In-114m		49.51 d	4.278×10^6	8.572×10^{14}
In-115m		4.486 h	1.615×10^4	2.251×10^{17}
Ir-189	Iridium (77)	13.3 d	1.149×10^6	1.925×10^{15}
Ir-190		12.1 d	1.045×10^6	2.104×10^{15}

Radionuclide	Element and atomic number	Half-life		Specific activity (Bq/g)
		T _{1/2} (a, d, h, min)	T _{1/2} (s)	
Ir-192		74.02 d	6.395×10^6	3.404×10^{14}
Ir-193m		10.53 d	9.098×10^5	2.378×10^{15}
Ir-194		19.15 h	6.894×10^4	3.125×10^{16}
K-40	Potassium (19)	1.28×10^9 a	4.037×10^{16}	2.589×10^5
K-42		12.36 h	4.450×10^4	2.237×10^{17}
K-43		22.6 h	8.136×10^4	1.195×10^{17}
Kr-81	Krypton (36)	2.1×10^5 a	6.623×10^{12}	7.792×10^8
Kr-85		10.72 a	3.381×10^8	1.455×10^{13}
Kr-85m		4.48 h	1.613×10^4	3.049×10^{17}
Kr-87		76.3 min	4.578×10^3	1.049×10^{18}
La-137	Lanthanum (57)	6.0×10^4 a	1.892×10^{12}	1.612×10^9
La-140		40.272 h	1.450×10^5	2.059×10^{16}
Lu-172	Lutetium (71)	6.7 d	5.789×10^5	4.198×10^{15}
Lu-173		1.37 a	4.320×10^7	5.592×10^{13}
Lu-174		3.31 a	1.044×10^8	2.301×10^{13}
Lu-174m		142 d	1.227×10^7	1.958×10^{14}
Lu-177		6.71 d	5.797×10^5	4.073×10^{15}
Mg-28	Magnesium (12)	20.91 h	7.528×10^4	1.983×10^{17}
Mn-52	Manganese (25)	5.591 d	4.831×10^5	1.664×10^{16}

Radionuclide	Element and atomic number	Half-life		Specific activity (Bq/g)
		T _{1/2} (a, d, h, min)	T _{1/2} (s)	
Mn-53		3.7 × 10 ⁶ a	1.167 × 10 ¹⁴	6.759 × 10 ⁷
Mn-54		312.5 d	2.700 × 10 ⁷	2.867 × 10 ¹⁴
Mn-56		2.5785 h	9.283 × 10 ³	8.041 × 10 ¹⁷
Mo-93	Molybdenum (42)	3500 a	1.104 × 10 ¹¹	4.072 × 10 ¹⁰
Mo-99		66 h	2.376 × 10 ⁵	1.777 × 10 ¹⁶
N-13	Nitrogen (7)	9.965 min	5.979 × 10 ²	5.378 × 10 ¹⁹
Na-22	Sodium (11)	2.602 a	8.206 × 10 ⁷	2.315 × 10 ¹⁴
Na-24		15 h	5.400 × 10 ⁴	3.225 × 10 ¹⁷
Nb-93m	Niobium (41)	13.6 a	4.289 × 10 ⁸	1.048 × 10 ¹³
Nb-94		2.03 × 10 ⁴ a	6.402 × 10 ¹¹	6.946 × 10 ⁹
Nb-95		35.15 d	3.037 × 10 ⁶	1.449 × 10 ¹⁵
Nb-97		72.1 min	4.326 × 10 ³	9.961 × 10 ¹⁷
Nd-147	Neodymium (60)	10.98 d	9.487 × 10 ⁵	2.997 × 10 ¹⁵
Nd-149		1.73 h	6.228 × 10 ³	4.504 × 10 ¹⁷
Ni-57	Nickel (28)	35.60 h	1.282 × 10 ⁵	5.718 × 10 ¹⁶
Ni-59		7.5 × 10 ⁴ a	2.365 × 10 ¹²	2.995 × 10 ⁹
Ni-63		96 a	3.027 × 10 ⁹	2.192 × 10 ¹²
Ni-65		2.52 h	9.072 × 10 ³	7.089 × 10 ¹⁷

Radionuclide	Element and atomic number	Half-life		Specific activity (Bq/g)
		T _{1/2} (a, d, h, min)	T _{1/2} (s)	
Np-235	Neptunium (93)	396.1 d	3.422×10^7	5.197×10^{13}
Np-236(long lived)		1.15×10^5 a	3.627×10^{12}	4.884×10^8
Np-236(short lived)		22.5 h	8.100×10^4	2.187×10^{16}
Np-237		2.14×10^6 a	6.749×10^{13}	2.613×10^7
Np-239		2.355 d	2.035×10^5	8.596×10^{15}
Os-185	Osmium (76)	94 d	8.122×10^6	2.782×10^{14}
Os-191		15.4 d	1.331×10^6	1.645×10^{15}
Os-191m		13.03 h	4.691×10^4	4.665×10^{16}
Os-193		30 h	1.080×10^5	2.005×10^{16}
Os-194		6 a	1.892×10^8	1.139×10^{13}
P-32		Phosphorus (15)	14.29 d	1.235×10^6
P-33	25.4 d		2.195×10^6	5.772×10^{15}
Pa-230	Protactinium (91)	17.4 d	1.503×10^6	1.209×10^{15}
Pa-231		32760 a	1.033×10^{12}	1.752×10^9
Pa-233		27 d	2.333×10^6	7.690×10^{14}
Pb-201	Lead (82)	9.4 h	3.384×10^4	6.145×10^{16}
Pb-202		3.0×10^5 a	9.461×10^{12}	2.187×10^8
Pb-203		52.05 h	1.874×10^5	1.099×10^{16}

Radionuclide	Element and atomic number	Half-life		Specific activity (Bq/g)
		T _{1/2} (a, d, h, min)	T _{1/2} (s)	
Pb-205		1.43 × 10 ⁷ a	4.510 × 10 ¹⁴	4.521 × 10 ⁶
Pb-210		22.3 a	7.033 × 10 ⁸	2.830 × 10 ¹²
Pb-212		10.64 h	3.830 × 10 ⁴	5.147 × 10 ¹⁶
Pd-103	Palladium (46)	16.96 d	1.465 × 10 ⁶	2.769 × 10 ¹⁵
Pd-107		6.5 × 10 ⁶ a	2.050 × 10 ¹⁴	1.906 × 10 ⁷
Pd-109		13.427 h	4.834 × 10 ⁴	7.934 × 10 ¹⁶
Pm-143	Promethium (61)	265 d	2.290 × 10 ⁷	1.277 × 10 ¹⁴
Pm-144		363 d	3.136 × 10 ⁷	9.255 × 10 ¹³
Pm-145		17.7 a	5.582 × 10 ⁸	5.165 × 10 ¹²
Pm-147		2.6234 a	8.273 × 10 ⁷	3.437 × 10 ¹³
Pm-148m		41.3 d	3.568 × 10 ⁶	7.915 × 10 ¹⁴
Pm-149		53.08 h	1.911 × 10 ⁵	1.468 × 10 ¹⁶
Pm-151		28.4 h	1.022 × 10 ⁵	2.708 × 10 ¹⁶
Po-210	Polonium (84)	138.38 d	1.196 × 10 ⁷	1.665 × 10 ¹⁴
Pr-142	Praseodymium (59)	19.13 h	6.887 × 10 ⁴	4.274 × 10 ¹⁶
Pr-143		13.56 d	1.172 × 10 ⁶	2.495 × 10 ¹⁵
Pt-188	Platinum (78)	10.2 d	8.813 × 10 ⁵	2.523 × 10 ¹⁵
Pt-191		2.8 d	2.419 × 10 ⁵	9.046 × 10 ¹⁵
Pt-193		50 a	1.577 × 10 ⁹	1.374 × 10 ¹²

Radionuclide	Element and atomic number	Half-life		Specific activity (Bq/g)
		T _{1/2} (a, d, h, min)	T _{1/2} (s)	
Pt-193m		4.33 d	3.741×10^5	5.789×10^{15}
Pt-195m		4.02 d	3.473×10^5	6.172×10^{15}
Pt-197		18.3 h	6.588×10^4	3.221×10^{16}
Pt-197m		94.4 min	5.664×10^3	3.746×10^{17}
Pu-236	Plutonium (94)	2.851 a	8.991×10^7	1.970×10^{13}
Pu-237		45.3 d	3.914×10^6	4.506×10^{14}
Pu-238		87.74 a	2.767×10^9	6.347×10^{11}
Pu-239		24065 a	7.589×10^{11}	2.305×10^9
Pu-240		6537 a	2.062×10^{11}	8.449×10^9
Pu-241		14.4 a	4.541×10^8	3.819×10^{12}
Pu-242		3.763×10^5 a	1.187×10^{13}	1.456×10^8
Pu-244		8.26×10^7 a	2.605×10^{15}	6.577×10^5
Ra-223	Radium (88)	11.434 d	9.879×10^5	1.897×10^{15}
Ra-224		3.66 d	3.162×10^5	5.901×10^{15}
Ra-225		14.8 d	1.279×10^6	1.453×10^{15}
Ra-226		1600 a	5.046×10^{10}	3.666×10^{10}
Ra-228		5.75 a	1.813×10^8	1.011×10^{13}
Rb-81	Rubidium (37)	4.58 h	1.649×10^4	3.130×10^{17}
Rb-83		86.2 d	7.448×10^6	6.762×10^{14}
Rb-84		32.77 d	2.831×10^6	1.758×10^{15}
Rb-86		18.66 d	1.612×10^6	3.015×10^{15}

Radionuclide	Element and atomic number	Half-life		Specific activity (Bq/g)
		T _{1/2} (a, d, h, min)	T _{1/2} (s)	
Rb-87		4.7 × 10 ¹⁰ a	1.482 × 10 ¹⁸	3.242 × 10 ³
Re-184	Rhenium (75)	38 d	3.283 × 10 ⁶	6.919 × 10 ¹⁴
Re-184m		165 d	1.426 × 10 ⁷	1.594 × 10 ¹⁴
Re-186		90.64 h	3.263 × 10 ⁵	6.887 × 10 ¹⁵
Re-187		5.0 × 10 ¹⁰ a	1.577 × 10 ¹⁸	1.418 × 10 ³
Re-188		16.98 h	6.113 × 10 ⁴	3.637 × 10 ¹⁶
Re-189		24.3 h	8.748 × 10 ⁴	2.528 × 10 ¹⁶
Rh-99	Rhodium (45)	16 d	1.382 × 10 ⁶	3.054 × 10 ¹⁵
Rh-101		3.2 a	1.009 × 10 ⁸	4.101 × 10 ¹³
Rh-102		2.9 a	9.145 × 10 ⁷	4.481 × 10 ¹³
Rh-102m		207 d	1.788 × 10 ⁷	2.291 × 10 ¹⁴
Rh-103m		56.12 min	3.367 × 10 ³	1.205 × 10 ¹⁸
Rh-105		35.36 h	1.273 × 10 ⁵	3.127 × 10 ¹⁶
Rn-222	Radon (86)	3.8235 d	3.304 × 10 ⁵	5.700 × 10 ¹⁵
Ru-97	Ruthenium (44)	2.9 d	2.506 × 10 ⁵	1.720 × 10 ¹⁶
Ru-103		39.28 d	3.394 × 10 ⁶	1.196 × 10 ¹⁵
Ru-105		4.44 h	1.598 × 10 ⁴	2.491 × 10 ¹⁷
Ru-106		368.2 d	3.181 × 10 ⁷	1.240 × 10 ¹⁴
S-35	Sulphur (16)	87.44 d	7.555 × 10 ⁶	1.581 × 10 ¹⁵

Radionuclide	Element and atomic number	Half-life		Specific activity (Bq/g)
		T _{1/2} (a, d, h, min)	T _{1/2} (s)	
Sb-122	Antimony (51)	2.7 d	2.333×10^5	1.469×10^{16}
Sb-124		60.2 d	5.201×10^6	6.481×10^{14}
Sb-125		2.77 a	8.735×10^7	3.828×10^{13}
Sb-126		12.4 d	1.071×10^6	3.096×10^{15}
Sc-44	Scandium (21)	3.927 h	1.414×10^4	6.720×10^{17}
Sc-46		83.83 d	7.243×10^6	1.255×10^{15}
Sc-47		3.351 d	2.895×10^5	3.072×10^{16}
Sc-48		43.7 h	1.573×10^5	5.535×10^{16}
Se-75	Selenium (34)	119.8 d	1.035×10^7	5.384×10^{14}
Se-79		6.5×10^4 a	2.050×10^{12}	2.581×10^9
Si-31	Silicon (14)	157.3 min	9.438×10^3	1.429×10^{18}
Si-32		450 a	1.419×10^{10}	9.205×10^{11}
Sm-145	Samarium (62)	340 d	2.938×10^7	9.813×10^{13}
Sm-147		1.06×10^{11} a	3.343×10^{18}	8.506×10^2
Sm-151		90 a	2.838×10^9	9.753×10^{11}
Sm-153		46.7 h	1.681×10^5	1.625×10^{16}
Sn-113	Tin (50)	115.1 d	9.945×10^6	3.720×10^{14}
Sn-117m		13.61 d	1.176×10^6	3.038×10^{15}
Sn-119m		293 d	2.532×10^7	1.388×10^{14}
Sn-121m		55 a	1.734×10^9	1.992×10^{12}

Radionuclide	Element and atomic number	Half-life		Specific activity (Bq/g)
		T _{1/2} (a, d, h, min)	T _{1/2} (s)	
Sn-123		129.2 d	1.116×10^7	3.044×10^{14}
Sn-125		9.64 d	8.329×10^5	4.015×10^{15}
Sn-126		1.0×10^5 a	3.154×10^{12}	1.052×10^9
Sr-82	Strontium (38)	25 d	2.160×10^6	2.360×10^{15}
Sr-83		32.41 h	1.167×10^5	4.314×10^{16}
Sr-85		64.84 d	5.602×10^6	8.778×10^{14}
Sr-85m		69.5 min	4.170×10^3	1.179×10^{18}
Sr-87m		2.805 h	1.010×10^4	4.758×10^{17}
Sr-89		50.5 d	4.363×10^6	1.076×10^{15}
Sr-90		29.12 a	9.183×10^8	5.057×10^{12}
Sr-91		9.5 h	3.420×10^4	1.343×10^{17}
Sr-92		2.71 h	9.756×10^3	4.657×10^{17}
T(H-3)	Tritium (1)	12.35 a	3.895×10^8	3.578×10^{14}
Ta-178(long lived)	Tantalum (73)	2.2 h	7.920×10^3	2.965×10^{17}
Ta-179		664.9 d	5.745×10^7	4.065×10^{13}
Ta-182		115 d	9.936×10^6	2.311×10^{14}
Tb-149	Terbium (65)	4.12 h	1.483×10^4	1.889×10^{17}
Tb-157		150 a	4.730×10^9	5.628×10^{11}
Tb-158		150 a	4.730×10^9	5.593×10^{11}
Tb-160		72.3 d	6.247×10^6	4.182×10^{14}
Tb-161		6.91 d	5.970×10^5	4.340×10^{15}

Radionuclide	Element and atomic number	Half-life		Specific activity (Bq/g)
		T _{1/2} (a, d, h, min)	T _{1/2} (s)	
Tc-95m	Technetium (43)	61 d	5.270×10^6	8.349×10^{14}
Tc-96		4.28 d	3.698×10^5	1.177×10^{16}
Tc-96m		51.5 min	3.090×10^3	1.409×10^{18}
Tc-97		2.6×10^6 a	8.199×10^{13}	5.256×10^7
Tc-97m		87 d	7.517×10^6	5.733×10^{14}
Tc-98		4.2×10^6 a	1.325×10^{14}	3.220×10^7
Tc-99		2.13×10^5 a	6.717×10^{12}	6.286×10^8
Tc-99m		6.02 h	2.167×10^4	1.948×10^{17}
Te-121	Tellurium (52)	17 d	1.469×10^6	2.352×10^{15}
Te-121m		154 d	1.331×10^7	2.596×10^{14}
Te-123m		119.7 d	1.034×10^7	3.286×10^{14}
Te-125m		58 d	5.011×10^6	6.673×10^{14}
Te-127		9.35 h	3.366×10^4	9.778×10^{16}
Te-127m		109 d	9.418×10^6	3.495×10^{14}
Te-129		69.6 min	4.176×10^3	7.759×10^{17}
Te-129m		33.6 d	2.903×10^6	1.116×10^{15}
Te-131m		30 h	1.080×10^5	2.954×10^{16}
Te-132		78.2 h	2.815×10^5	1.125×10^{16}
Th-227	Thorium (90)	18.718 d	1.617×10^6	1.139×10^{15}
Th-228		1.9131 a	6.033×10^7	3.039×10^{13}
Th-229		7340 a	2.315×10^{11}	7.886×10^9

Radionuclide	Element and atomic number	Half-life		Specific activity (Bq/g)
		$T_{1/2}$ (a, d, h, min)	$T_{1/2}$ (s)	
Th-230		7.7×10^4 a	2.428×10^{12}	7.484×10^8
Th-231		25.52 h	9.187×10^4	1.970×10^{16}
Th-232		1.405×10^{10} a	4.431×10^{17}	4.066×10^3
Th-234		24.1 d	2.082×10^6	8.579×10^{14}
Ti-44	Titanium (22)	47.3 a	1.492×10^9	6.369×10^{12}
Tl-200	Thallium (81)	26.1 h	9.396×10^4	2.224×10^{16}
Tl-201		3.044 d	2.630×10^5	7.907×10^{15}
Tl-202		12.23 d	1.057×10^6	1.958×10^{15}
Tl-204		3.779 a	1.192×10^8	1.719×10^{13}
Tm-167	Thulium (69)	9.24 d	7.983×10^5	3.135×10^{15}
Tm-170		128.6 d	1.111×10^7	2.213×10^{14}
Tm-171		1.92 a	6.055×10^7	4.037×10^{13}
U-230	Uranium (92)	20.8 d	1.797×10^6	1.011×10^{15}
U-232		72 a	2.271×10^9	7.935×10^{11}
U-233		1.585×10^5 a	4.998×10^{12}	3.589×10^8
U-234		2.445×10^5 a	7.711×10^{12}	2.317×10^8
U-235		7.038×10^8 a	2.220×10^{16}	8.014×10^4
U-236		2.3415×10^7 a	7.384×10^{14}	2.399×10^6
U-238		4.468×10^9 a	1.409×10^{17}	1.246×10^4

Radionuclide	Element and atomic number	Half-life		Specific activity (Bq/g)
		T _{1/2} (a, d, h, min)	T _{1/2} (s)	
V-48	Vanadium (23)	16.238 d	1.403 × 10 ⁶	6.207 × 10 ¹⁵
V-49		330 d	2.851 × 10 ⁷	2.992 × 10 ¹⁴
W-178	Tungsten (74)	21.7 d	1.875 × 10 ⁶	1.253 × 10 ¹⁵
W-181		121.2 d	1.047 × 10 ⁷	2.205 × 10 ¹⁴
W-185		75.1 d	6.489 × 10 ⁶	3.482 × 10 ¹⁴
W-187		23.9 h	8.604 × 10 ⁴	2.598 × 10 ¹⁶
W-188		69.4 d	5.996 × 10 ⁶	3.708 × 10 ¹⁴
Xe-122		Xenon (54)	20.1 h	7.236 × 10 ⁴
Xe-123	2.08 h		7.488 × 10 ³	4.538 × 10 ¹⁷
Xe-127	36.41 d		3.146 × 10 ⁶	1.046 × 10 ¹⁵
Xe-131m	11.9 d		1.028 × 10 ⁶	3.103 × 10 ¹⁵
Xe-133	5.245 d		4.532 × 10 ⁵	6.935 × 10 ¹⁵
Xe-135	9.09 h		3.272 × 10 ⁴	9.462 × 10 ¹⁶
Y-87	Yttrium (39)		80.3 h	2.891 × 10 ⁵
Y-88		106.64 d	9.214 × 10 ⁶	5.155 × 10 ¹⁴
Y-90		64 h	2.304 × 10 ⁵	2.016 × 10 ¹⁶
Y-91		58.51 d	5.055 × 10 ⁶	9.086 × 10 ¹⁴
Y-91m		49.71 min	2.983 × 10 ³	1.540 × 10 ¹⁸
Y-92		3.54 h	1.274 × 10 ⁴	3.565 × 10 ¹⁷
Y-93		10.1 h	3.636 × 10 ⁴	1.236 × 10 ¹⁷
Yb-169		Ytterbium (70)	32.01 d	2.766 × 10 ⁶

Radionuclide	Element and atomic number	Half-life		Specific activity (Bq/g)
		T _{1/2} (a, d, h, min)	T _{1/2} (s)	
Yb-175		4.19 d	3.620×10^5	6.598×10^{15}
Zn-65	Zinc (30)	243.9 d	2.107×10^7	3.052×10^{14}
Zn-69		57 min	3.420×10^3	1.771×10^{18}
Zn-69m		13.76 h	4.954×10^4	1.223×10^{17}
Zr-88	Zirconium (40)	83.4 d	7.206×10^6	6.592×10^{14}
Zr-93		1.53×10^6 a	4.825×10^{13}	9.315×10^7
Zr-95		63.98 d	5.528×10^6	7.960×10^{14}
Zr-97		16.9 h	6.084×10^4	7.083×10^1

TABLE II.2. DOSE AND DOSE RATE COEFFICIENTS OF RADIONUCLIDES

EXPLANATORY NOTES

- (a) Effective dose rate coefficient for external dose due to photons calculated at 1 m.
- (b) Equivalent skin dose rate coefficient for external dose due to beta emission calculated at 1 m.
- (c) Effective dose coefficient for inhalation.
- (d) Equivalent skin dose coefficient for the skin dose contamination.

(*) For the effective dose coefficient and the equivalent skin dose coefficient for submersion dose due to gaseous isotopes see Table I.1 of Appendix I.

Radionuclide	\dot{e}_{pt} (a)	\dot{e}_{β} (b)	e_{inh} (c)	\dot{h}_{skin} (d)
	(Sv·Bq ⁻¹ ·h ⁻¹)	(Sv·Bq ⁻¹ ·h ⁻¹)	(Sv·Bq ⁻¹)	(Sv·m ² ·TBq ⁻¹ ·s ⁻¹)
Ac-225	2.0×10^{-14}	1.2×10^{-12}	7.9×10^{-06}	9.3×10^{-02}
Ac-227	9.6×10^{-17}	7.7×10^{-15}	5.4×10^{-04}	7.6×10^{-04}
Ac-228	8.3×10^{-14}	1.8×10^{-12}	2.5×10^{-08}	5.3×10^{-02}
Ag-105	5.0×10^{-14}	1.0×10^{-15}	7.8×10^{-10}	1.1×10^{-03}
Ag-108m	1.5×10^{-13}	1.7×10^{-13}	3.5×10^{-08}	4.7×10^{-03}
Ag-110m	2.4×10^{-13}	5.3×10^{-14}	1.2×10^{-08}	1.4×10^{-02}
Ag-111	2.4×10^{-15}	5.3×10^{-13}	1.7×10^{-09}	4.5×10^{-02}
Al-26	2.3×10^{-13}	7.1×10^{-12}	1.8×10^{-08}	3.9×10^{-02}
Am-241	3.3×10^{-15}	1.0×10^{-15}	3.9×10^{-05}	7.4×10^{-05}
Am-242m	2.5×10^{-15}	2.0×10^{-14}	3.5×10^{-05}	3.3×10^{-02}
Am-243	2.0×10^{-14}	3.8×10^{-15}	3.9×10^{-05}	6.8×10^{-02}
Ar-37	1.0×10^{-16}	1.0×10^{-15}	—	2.8×10^{-05}
Ar-39	(*) —	1.4×10^{-14}	—	—
Ar-41	(*) 1.1×10^{-13}	3.2×10^{-12}	—	—
As-72	1.6×10^{-13}	3.6×10^{-12}	9.2×10^{-10}	4.2×10^{-02}
As-73	1.1×10^{-15}	1.0×10^{-15}	9.3×10^{-10}	2.8×10^{-05}
As-74	7.1×10^{-14}	5.9×10^{-13}	2.1×10^{-09}	2.9×10^{-02}
As-76	4.0×10^{-14}	4.0×10^{-12}	7.4×10^{-10}	4.7×10^{-02}
As-77	7.7×10^{-16}	5.6×10^{-14}	3.8×10^{-10}	4.2×10^{-02}
At-211	4.0×10^{-15}	1.0×10^{-15}	9.8×10^{-08}	6.3×10^{-05}
Au-193	1.4×10^{-14}	1.0×10^{-15}	1.2×10^{-10}	1.5×10^{-02}
Au-194	9.1×10^{-14}	1.0×10^{-15}	2.5×10^{-10}	4.6×10^{-03}
Au-195	7.7×10^{-15}	1.0×10^{-15}	1.6×10^{-09}	5.0×10^{-03}
Au-198	3.8×10^{-14}	9.1×10^{-13}	8.4×10^{-10}	4.6×10^{-02}
Au-199	7.1×10^{-15}	1.0×10^{-15}	7.5×10^{-10}	4.4×10^{-02}

Radionuclide	\dot{e}_{pt} (a)	\dot{e}_{β} (b)	e_{inh} (c)	\dot{h}_{skin} (d)
	(Sv·Bq ⁻¹ ·h ⁻¹)	(Sv·Bq ⁻¹ ·h ⁻¹)	(Sv·Bq ⁻¹)	(Sv·m ² ·TBq ⁻¹ ·s ⁻¹)
Ba-131	6.3×10^{-14}	1.0×10^{-15}	2.6×10^{-10}	1.3×10^{-02}
Ba-133	3.8×10^{-14}	1.0×10^{-15}	1.5×10^{-09}	2.7×10^{-03}
Ba-133m	6.7×10^{-15}	1.0×10^{-15}	1.9×10^{-10}	4.5×10^{-02}
Ba-135m	6.3×10^{-15}	1.0×10^{-15}	1.5×10^{-10}	4.7×10^{-02}
Ba-140	1.6×10^{-13}	2.2×10^{-12}	2.1×10^{-09}	9.0×10^{-02}
Be-7	4.8×10^{-15}	1.0×10^{-15}	5.2×10^{-11}	2.8×10^{-05}
Be-10	—	1.7×10^{-14}	3.2×10^{-08}	14.8×10^{-02}
Bi-205	1.4×10^{-13}	1.0×10^{-15}	9.2×10^{-10}	2.5×10^{-03}
Bi-206	2.9×10^{-13}	1.0×10^{-15}	1.7×10^{-09}	2.4×10^{-02}
Bi-207	1.4×10^{-13}	1.0×10^{-15}	5.2×10^{-09}	5.5×10^{-03}
Bi-210	—	7.7×10^{-13}	8.4×10^{-08}	4.5×10^{-02}
Bi-210m	2.3×10^{-14}	1.6×10^{-12}	3.1×10^{-06}	5.7×10^{-02}
Bi-212	1.0×10^{-13}	1.5×10^{-12}	3.0×10^{-08}	4.8×10^{-02}
Bk-247	9.1×10^{-15}	1.0×10^{-15}	6.5×10^{-05}	2.0×10^{-02}
Bk-249	1.0×10^{-16}	1.0×10^{-15}	1.5×10^{-07}	2.3×10^{-03}
Br-76	2.3×10^{-13}	1.6×10^{-12}	4.2×10^{-10}	2.8×10^{-02}
Br-77	2.9×10^{-14}	1.0×10^{-15}	8.7×10^{-11}	1.2×10^{-03}
Br-82	2.4×10^{-13}	1.0×10^{-15}	6.4×10^{-10}	3.6×10^{-02}
C-11	1.0×10^{-13}	5.0×10^{-13}	5.0×10^{-11}	4.8×10^{-02}
C-14	—	1.0×10^{-15}	5.8×10^{-10}	8.8×10^{-03}
Ca-41	1.0×10^{-16}	1.0×10^{-15}	—	—
Ca-45	1.0×10^{-16}	1.0×10^{-15}	2.7×10^{-09}	2.3×10^{-02}
Ca-47	3.7×10^{-14}	2.7×10^{-14}	2.5×10^{-09}	8.4×10^{-02}
Cd-109	3.4×10^{-15}	1.0×10^{-15}	8.1×10^{-09}	1.4×10^{-02}
Cd-113m		1.1×10^{-14}	1.1×10^{-07}	4.0×10^{-02}
Cd-115	2.6×10^{-14}	3.0×10^{-13}	1.1×10^{-09}	7.1×10^{-02}
Cd-115m	2.0×10^{-15}	1.9×10^{-12}	7.3×10^{-09}	4.6×10^{-02}
Ce-139	1.5×10^{-14}	1.0×10^{-15}	1.8×10^{-09}	1.3×10^{-02}
Ce-141	6.3×10^{-15}	3.1×10^{-15}	3.6×10^{-09}	4.8×10^{-02}
Ce-143	2.7×10^{-14}	1.1×10^{-12}	8.1×10^{-10}	4.6×10^{-02}
Ce-144	4.5×10^{-15}	4.0×10^{-12}	4.9×10^{-08}	7.3×10^{-02}
Cf-248	1.5×10^{-16}	1.0×10^{-15}	8.2×10^{-06}	2.8×10^{-05}
Cf-249	3.1×10^{-14}	1.0×10^{-15}	6.6×10^{-05}	6.1×10^{-03}
Cf-250	1.5×10^{-16}	1.0×10^{-15}	3.2×10^{-05}	2.8×10^{-05}
Cf-251	1.1×10^{-14}	1.0×10^{-15}	6.7×10^{-05}	5.4×10^{-02}
Cf-252	7.5×10^{-13}	1.0×10^{-15}	1.8×10^{-05}	5.4×10^{-05}
Cf-253	8.1×10^{-18}	1.0×10^{-15}	1.2×10^{-06}	2.3×10^{-02}
Cf-254	7.1×10^{-11}	1.0×10^{-15}	3.7×10^{-05}	2.8×10^{-05}
Cl-36	1.0×10^{-16}	1.0×10^{-13}	6.9×10^{-09}	4.4×10^{-02}
Cl-38	1.2×10^{-13}	4.5×10^{-12}	4.7×10^{-11}	5.0×10^{-02}

Radionuclide	\dot{e}_{pt} (a)	\dot{e}_{β} (b)	e_{inh} (c)	\dot{h}_{skin} (d)
	(Sv·Bq ⁻¹ ·h ⁻¹)	(Sv·Bq ⁻¹ ·h ⁻¹)	(Sv·Bq ⁻¹)	(Sv·m ² ·TBq ⁻¹ ·s ⁻¹)
Cm-240	2.2×10^{-16}	1.0×10^{-15}	2.9×10^{-06}	2.8×10^{-05}
Cm-241	4.5×10^{-14}	1.0×10^{-15}	3.8×10^{-08}	1.9×10^{-02}
Cm-242	2.0×10^{-16}	1.0×10^{-15}	4.8×10^{-06}	2.8×10^{-05}
Cm-243	1.2×10^{-14}	1.0×10^{-15}	3.8×10^{-05}	3.4×10^{-02}
Cm-244	1.9×10^{-16}	1.0×10^{-15}	3.1×10^{-05}	2.8×10^{-05}
Cm-245	7.9×10^{-15}	1.0×10^{-15}	5.5×10^{-05}	1.0×10^{-02}
Cm-246	1.7×10^{-16}	1.0×10^{-15}	5.5×10^{-05}	2.8×10^{-05}
Cm-247	3.1×10^{-14}	6.3×10^{-15}	5.1×10^{-05}	—
Cm-248	5.6×10^{-12}	1.0×10^{-15}	2.0×10^{-04}	—
Co-55	1.9×10^{-13}	1.0×10^{-12}	5.5×10^{-10}	3.6×10^{-02}
Co-56	3.0×10^{-13}	6.7×10^{-14}	6.3×10^{-09}	9.5×10^{-03}
Co-57	1.0×10^{-14}	1.0×10^{-15}	9.4×10^{-10}	2.1×10^{-03}
Co-58	9.1×10^{-14}	1.3×10^{-15}	2.0×10^{-09}	7.4×10^{-03}
Co-58m	1.0×10^{-16}	1.0×10^{-15}	5.0×10^{-11}	2.8×10^{-05}
Co-60	2.2×10^{-13}	1.4×10^{-15}	2.9×10^{-08}	2.9×10^{-02}
Cr-51	2.9×10^{-15}	1.0×10^{-15}	5.0×10^{-11}	2.8×10^{-05}
Cs-129	2.8×10^{-14}	1.0×10^{-15}	5.0×10^{-11}	7.4×10^{-04}
Cs-131	3.2×10^{-15}	1.0×10^{-15}	5.0×10^{-11}	2.8×10^{-05}
Cs-132	6.7×10^{-14}	1.0×10^{-15}	2.4×10^{-10}	1.1×10^{-03}
Cs-134	1.4×10^{-13}	2.8×10^{-13}	6.8×10^{-09}	3.0×10^{-02}
Cs-134m	2.7×10^{-15}	1.0×10^{-15}	5.0×10^{-11}	4.4×10^{-02}
Cs-135	—	1.0×10^{-15}	—	1.9×10^{-02}
Cs-136	2.0×10^{-13}	1.2×10^{-15}	1.3×10^{-09}	4.0×10^{-02}
Cs-137	5.6×10^{-14}	1.2×10^{-13}	4.8×10^{-09}	4.4×10^{-02}
Cu-64	1.8×10^{-14}	9.1×10^{-15}	1.2×10^{-10}	2.4×10^{-02}
Cu-67	1.0×10^{-14}	2.4×10^{-15}	5.8×10^{-10}	4.0×10^{-02}
Dy-159	5.0×10^{-15}	1.0×10^{-15}	3.5×10^{-10}	2.8×10^{-05}
Dy-165	2.4×10^{-15}	1.1×10^{-12}	6.1×10^{-11}	4.6×10^{-02}
Dy-166	2.9×10^{-15}	1.2×10^{-12}	2.5×10^{-09}	8.1×10^{-02}
Er-169	1.0×10^{-16}	1.0×10^{-15}	9.8×10^{-10}	2.9×10^{-02}
Er-171	3.4×10^{-14}	1.2×10^{-12}	2.2×10^{-10}	5.5×10^{-02}
Eu-147	4.5×10^{-14}	1.0×10^{-15}	1.0×10^{-09}	7.4×10^{-03}
Eu-148	2.0×10^{-13}	1.0×10^{-15}	2.7×10^{-09}	1.4×10^{-03}
Eu-149	6.7×10^{-15}	1.0×10^{-15}	2.7×10^{-10}	3.8×10^{-04}
Eu-150 (long lived)	1.4×10^{-13}	1.0×10^{-15}	5.0×10^{-08}	3.9×10^{-03}
Eu-150 (short lived)	4.3×10^{-15}	6.7×10^{-13}	1.9×10^{-10}	4.0×10^{-02}
Eu-152	1.0×10^{-13}	5.9×10^{-15}	3.9×10^{-08}	2.1×10^{-02}
Eu-152m	2.7×10^{-14}	1.2×10^{-12}	2.2×10^{-10}	3.6×10^{-02}
Eu-154	1.1×10^{-13}	6.3×10^{-13}	5.0×10^{-08}	5.0×10^{-02}
Eu-155	5.3×10^{-15}	1.0×10^{-15}	6.5×10^{-09}	8.7×10^{-03}
Eu-156	1.1×10^{-13}	1.4×10^{-12}	3.3×10^{-09}	4.2×10^{-02}
F-18	1.0×10^{-13}	3.6×10^{-14}	6.0×10^{-11}	4.8×10^{-02}
Fe-52	2.4×10^{-13}	3.1×10^{-12}	6.3×10^{-10}	7.4×10^{-02}

Radionuclide	\dot{e}_{pt} (a)	\dot{e}_{β} (b)	e_{inh} (c)	\dot{h}_{skin} (d)
	(Sv·Bq ⁻¹ ·h ⁻¹)	(Sv·Bq ⁻¹ ·h ⁻¹)	(Sv·Bq ⁻¹)	(Sv·m ² ·TBq ⁻¹ ·s ⁻¹)
Fe-55	1.0×10^{-16}	1.0×10^{-15}	7.7×10^{-10}	2.8×10^{-05}
Fe-59	1.1×10^{-13}	2.3×10^{-14}	3.5×10^{-09}	3.1×10^{-02}
Fe-60	5.0×10^{-16}	1.0×10^{-15}	2.4×10^{-07}	7.6×10^{-03}
Ga-67	1.4×10^{-14}	1.0×10^{-15}	2.3×10^{-10}	8.6×10^{-03}
Ga-68	9.1×10^{-14}	2.2×10^{-12}	5.1×10^{-11}	4.2×10^{-02}
Ga-72	2.3×10^{-13}	2.7×10^{-12}	5.5×10^{-10}	4.5×10^{-02}
Gd-146	1.9×10^{-13}	3.4×10^{-15}	6.8×10^{-09}	2.7×10^{-02}
Gd-148			2.5×10^{-05}	
Gd-153	1.1×10^{-14}	1.0×10^{-15}	2.1×10^{-09}	3.1×10^{-03}
Gd-159	4.8×10^{-15}	3.2×10^{-13}	2.7×10^{-10}	4.4×10^{-02}
Ge-68	9.1×10^{-14}	2.2×10^{-12}	1.3×10^{-08}	4.2×10^{-02}
Ge-69	9.1×10^{-14}	4.5×10^{-13}	2.9×10^{-10}	1.6×10^{-02}
Ge-71	1.9×10^{-16}	1.0×10^{-15}	5.0×10^{-11}	2.8×10^{-05}
Ge-77	9.1×10^{-14}	3.0×10^{-12}	3.6×10^{-10}	4.6×10^{-02}
Hf-172	1.7×10^{-13}	1.0×10^{-15}	3.2×10^{-08}	1.6×10^{-02}
Hf-175	3.4×10^{-14}	1.0×10^{-15}	1.1×10^{-09}	5.9×10^{-03}
Hf-181	5.3×10^{-14}	1.0×10^{-15}	4.7×10^{-09}	5.6×10^{-02}
Hf-182	2.2×10^{-14}	1.0×10^{-15}	—	—
Hg-194	9.1×10^{-14}	1.0×10^{-15}	4.0×10^{-08}	4.6×10^{-03}
Hg-195m	3.2×10^{-14}	1.0×10^{-15}	9.4×10^{-09}	3.8×10^{-02}
Hg-197	6.3×10^{-15}	1.0×10^{-15}	4.4×10^{-09}	1.8×10^{-03}
Hg-197m	7.7×10^{-15}	1.0×10^{-15}	6.2×10^{-09}	7.9×10^{-02}
Hg-203	2.2×10^{-14}	1.0×10^{-15}	7.5×10^{-09}	2.5×10^{-02}
Ho-166	2.6×10^{-15}	2.3×10^{-12}	6.6×10^{-10}	4.8×10^{-02}
Ho-166m	1.6×10^{-13}	1.0×10^{-15}	1.1×10^{-07}	2.2×10^{-02}
I-123	1.6×10^{-14}	1.0×10^{-15}	2.1×10^{-10}	9.5×10^{-03}
I-124	9.1×10^{-14}	1.7×10^{-13}	1.2×10^{-08}	1.1×10^{-02}
I-125	6.3×10^{-15}	1.0×10^{-15}	1.4×10^{-08}	2.8×10^{-05}
I-126	4.3×10^{-14}	1.6×10^{-13}	2.9×10^{-08}	2.1×10^{-02}
I-129	3.4×10^{-15}	1.0×10^{-15}	—	—
I-131	3.6×10^{-14}	5.0×10^{-14}	2.0×10^{-08}	4.0×10^{-02}
I-132	2.1×10^{-13}	2.3×10^{-12}	2.8×10^{-10}	4.6×10^{-02}
I-133	5.6×10^{-14}	1.4×10^{-12}	4.5×10^{-09}	4.5×10^{-02}
I-134	2.4×10^{-13}	3.1×10^{-12}	7.2×10^{-11}	4.7×10^{-02}
I-135	1.2×10^{-13}	1.6×10^{-12}	9.6×10^{-10}	4.5×10^{-02}
In-111	3.6×10^{-14}	1.0×10^{-15}	2.3×10^{-10}	9.3×10^{-03}
In-113m	2.4×10^{-14}	1.0×10^{-15}	5.0×10^{-11}	1.7×10^{-02}
In-114m	9.1×10^{-15}	1.0×10^{-15}	9.3×10^{-09}	5.8×10^{-02}
In-115m	1.5×10^{-14}	1.0×10^{-15}	6.0×10^{-11}	2.7×10^{-02}
Ir-189	7.7×10^{-15}	1.0×10^{-15}	5.5×10^{-10}	1.6×10^{-03}
Ir-190	1.3×10^{-13}	1.0×10^{-15}	2.3×10^{-09}	3.7×10^{-02}
Ir-192	7.7×10^{-14}	2.2×10^{-14}	6.2×10^{-09}	4.5×10^{-02}
Ir-193m	1.3×10^{-16}	1.0×10^{-15}	1.2×10^{-09}	9.3×10^{-03}

Radionuclide	\dot{e}_{pt} (a)	\dot{e}_{β} (b)	e_{inh} (c)	\dot{h}_{skin} (d)
	(Sv·Bq ⁻¹ ·h ⁻¹)	(Sv·Bq ⁻¹ ·h ⁻¹)	(Sv·Bq ⁻¹)	(Sv·m ² ·TBq ⁻¹ ·s ⁻¹)
Ir-194	8.3×10^{-15}	3.0×10^{-12}	5.6×10^{-10}	4.7×10^{-02}
K-40	1.4×10^{-14}	1.1×10^{-12}	—	—
K-42	2.4×10^{-14}	4.5×10^{-12}	1.3×10^{-10}	4.9×10^{-02}
K-43	9.1×10^{-14}	1.4×10^{-12}	1.5×10^{-10}	4.5×10^{-02}
Kr-81	(*) 9.1×10^{-16}	1.0×10^{-15}	—	—
Kr-85	(*) 2.1×10^{-16}	7.1×10^{-14}	—	—
Kr-85m	(*) 1.3×10^{-14}	1.3×10^{-13}	—	—
Kr-87	(*) 6.7×10^{-14}	4.8×10^{-12}	—	—
La-137	3.3×10^{-15}	1.0×10^{-15}	8.6×10^{-09}	2.8×10^{-05}
La-140	2.0×10^{-13}	2.7×10^{-12}	1.1×10^{-09}	4.7×10^{-02}
Lu-172	1.7×10^{-13}	1.0×10^{-15}	1.5×10^{-09}	1.3×10^{-02}
Lu-173	1.3×10^{-14}	1.0×10^{-15}	2.3×10^{-09}	1.6×10^{-03}
Lu-174	1.2×10^{-14}	1.0×10^{-15}	4.0×10^{-09}	9.6×10^{-04}
Lu-174m	6.3×10^{-15}	1.0×10^{-15}	3.8×10^{-09}	7.5×10^{-04}
Lu-177	3.0×10^{-15}	1.0×10^{-15}	1.1×10^{-09}	3.8×10^{-02}
Mg-28	2.7×10^{-13}	4.0×10^{-12}	1.9×10^{-09}	8.7×10^{-02}
Mn-52	3.1×10^{-13}	1.4×10^{-15}	1.4×10^{-09}	1.5×10^{-02}
Mn-53	1.0×10^{-16}	1.0×10^{-15}	—	—
Mn-54	7.7×10^{-14}	1.0×10^{-15}	1.5×10^{-09}	2.8×10^{-05}
Mn-56	1.5×10^{-13}	3.3×10^{-12}	1.3×10^{-10}	4.7×10^{-02}
Mo-93	1.2×10^{-15}	1.0×10^{-15}	2.2×10^{-09}	2.8×10^{-05}
Mo-99	1.6×10^{-14}	8.0×10^{-13}	9.7×10^{-10}	5.1×10^{-02}
N-13	1.0×10^{-13}	1.1×10^{-12}	—	4.8×10^{-02}
Na-22	2.0×10^{-13}	2.6×10^{-13}	1.3×10^{-09}	4.2×10^{-02}
Na-24	3.3×10^{-13}	5.0×10^{-12}	2.9×10^{-10}	4.7×10^{-02}
Nb-93m	2.0×10^{-16}	1.0×10^{-15}	1.6×10^{-09}	2.8×10^{-05}
Nb-94	1.5×10^{-13}	1.0×10^{-15}	4.5×10^{-08}	4.0×10^{-02}
Nb-95	7.1×10^{-14}	1.0×10^{-15}	1.6×10^{-09}	7.0×10^{-03}
Nb-97	6.3×10^{-14}	1.1×10^{-12}	4.7×10^{-11}	4.6×10^{-02}
Nd-147	1.4×10^{-14}	1.8×10^{-13}	2.3×10^{-09}	4.3×10^{-02}
Nd-149	3.4×10^{-14}	1.6×10^{-12}	9.0×10^{-11}	5.4×10^{-02}
Ni-57	1.7×10^{-13}	1.5×10^{-13}	5.1×10^{-10}	2.2×10^{-02}
Ni-59	1.0×10^{-16}	1.0×10^{-15}	—	—
Ni-63		1.0×10^{-15}	1.7×10^{-09}	2.8×10^{-05}
Ni-65	4.8×10^{-14}	2.3×10^{-12}	8.7×10^{-11}	4.6×10^{-02}
Np-235	7.1×10^{-16}	1.0×10^{-15}	4.0×10^{-10}	2.8×10^{-05}
Np-236 (long lived)	1.1×10^{-14}	1.0×10^{-15}	3.0×10^{-06}	5.6×10^{-02}
Np-236 (short lived)	4.3×10^{-15}	1.0×10^{-15}	5.0×10^{-09}	1.9×10^{-02}

Radionuclide	\dot{e}_{pt} (a)	\dot{e}_{β} (b)	e_{inh} (c)	\dot{h}_{skin} (d)
	(Sv·Bq ⁻¹ ·h ⁻¹)	(Sv·Bq ⁻¹ ·h ⁻¹)	(Sv·Bq ⁻¹)	(Sv·m ² ·TBq ⁻¹ ·s ⁻¹)
Np-237	3.3×10^{-15}	1.0×10^{-15}	2.1×10^{-05}	—
Np-239	1.5×10^{-14}	3.8×10^{-15}	9.0×10^{-10}	6.7×10^{-02}
Os-185	6.7×10^{-14}	1.0×10^{-15}	1.5×10^{-09}	1.2×10^{-03}
Os-191	6.7×10^{-15}	1.0×10^{-15}	1.8×10^{-09}	1.2×10^{-02}
Os-191m	7.7×10^{-16}	1.0×10^{-15}	1.5×10^{-10}	1.0×10^{-03}
Os-193	6.7×10^{-15}	6.3×10^{-13}	5.1×10^{-10}	4.7×10^{-02}
Os-194	8.3×10^{-15}	3.2×10^{-12}	7.9×10^{-08}	4.7×10^{-02}
P-32	—	2.2×10^{-12}	3.2×10^{-09}	4.7×10^{-02}
P-33	—	1.0×10^{-15}	1.4×10^{-09}	2.3×10^{-02}
Pa-230	6.0×10^{-14}	1.0×10^{-15}	7.6×10^{-07}	1.3×10^{-02}
Pa-231	1.1×10^{-14}	1.0×10^{-15}	1.3×10^{-04}	1.5×10^{-03}
Pa-233	1.9×10^{-14}	1.0×10^{-15}	3.7×10^{-09}	4.2×10^{-02}
Pb-201	6.7×10^{-14}	1.0×10^{-15}	6.5×10^{-11}	8.4×10^{-03}
Pb-202	1.1×10^{-16}	1.0×10^{-15}	—	1.7×10^{-03}
Pb-203	2.8×10^{-14}	1.0×10^{-15}	9.1×10^{-11}	1.1×10^{-02}
Pb-205	1.2×10^{-16}	1.0×10^{-15}	—	—
Pb-210	4.2×10^{-16}	7.7×10^{-13}	9.8×10^{-07}	4.5×10^{-02}
Pb-212	1.0×10^{-13}	1.4×10^{-12}	2.3×10^{-07}	1.0×10^{-01}
Pd-103	2.1×10^{-15}	1.0×10^{-15}	4.0×10^{-10}	2.8×10^{-05}
Pd-107	—	1.0×10^{-15}	—	—
Pd-109	1.4×10^{-15}	5.3×10^{-13}	3.6×10^{-10}	5.9×10^{-02}
Pm-143	3.0×10^{-14}	1.0×10^{-15}	1.4×10^{-09}	7.7×10^{-05}
Pm-144	1.5×10^{-13}	1.0×10^{-15}	7.8×10^{-09}	8.2×10^{-04}
Pm-145	3.8×10^{-15}	1.0×10^{-15}	3.4×10^{-09}	2.8×10^{-05}
Pm-147	1.0×10^{-16}	1.0×10^{-15}	4.7×10^{-09}	1.6×10^{-02}
Pm-148m	1.2×10^{-13}	1.3×10^{-13}	5.4×10^{-09}	3.9×10^{-02}
Pm-149	1.0×10^{-15}	5.9×10^{-13}	7.2×10^{-10}	4.5×10^{-02}
Pm-151	3.0×10^{-14}	5.6×10^{-13}	4.5×10^{-10}	4.5×10^{-02}
Po-210	7.9×10^{-19}	1.0×10^{-15}	3.0×10^{-06}	2.8×10^{-05}
Pr-142	5.0×10^{-15}	2.8×10^{-12}	5.6×10^{-10}	4.6×10^{-02}
Pr-143	1.0×10^{-16}	3.3×10^{-13}	2.3×10^{-09}	4.4×10^{-02}
Pt-188	1.0×10^{-13}	1.0×10^{-15}	8.8×10^{-10}	3.6×10^{-02}
Pt-191	2.8×10^{-14}	1.0×10^{-15}	1.1×10^{-10}	7.9×10^{-03}
Pt-193	1.1×10^{-16}	1.0×10^{-15}	5.0×10^{-11}	2.8×10^{-05}
Pt-193m	1.1×10^{-15}	1.0×10^{-15}	1.3×10^{-10}	5.1×10^{-02}
Pt-195m	6.7×10^{-15}	1.0×10^{-15}	1.9×10^{-10}	5.7×10^{-02}
Pt-197	2.1×10^{-15}	4.2×10^{-14}	9.1×10^{-11}	4.4×10^{-02}
Pt-197m	7.7×10^{-15}	1.0×10^{-15}	5.0×10^{-11}	4.8×10^{-02}
Pu-236	2.2×10^{-16}	1.0×10^{-15}	1.8×10^{-05}	4.3×10^{-05}
Pu-237	4.3×10^{-15}	1.0×10^{-15}	3.6×10^{-10}	2.3×10^{-04}
Pu-238	1.9×10^{-16}	1.0×10^{-15}	4.3×10^{-05}	2.8×10^{-05}
Pu-239	7.5×10^{-17}	1.0×10^{-15}	4.7×10^{-05}	—
Pu-240	1.8×10^{-16}	1.0×10^{-15}	4.7×10^{-05}	—

Radionuclide	\dot{e}_{pt} (a)	\dot{e}_{β} (b)	e_{inh} (c)	\dot{h}_{skin} (d)
	(Sv·Bq ⁻¹ ·h ⁻¹)	(Sv·Bq ⁻¹ ·h ⁻¹)	(Sv·Bq ⁻¹)	(Sv·m ² ·TBq ⁻¹ ·s ⁻¹)
Pu-241	1.0×10^{-16}	1.0×10^{-15}	8.5×10^{-07}	2.8×10^{-05}
Pu-242	1.5×10^{-16}	1.0×10^{-15}	4.4×10^{-05}	—
Pu-244	3.2×10^{-14}	2.6×10^{-12}	4.4×10^{-05}	—
Ra-223	2.6×10^{-14}	2.5×10^{-12}	6.9×10^{-06}	1.1×10^{-01}
Ra-224	9.1×10^{-14}	2.3×10^{-12}	3.1×10^{-06}	1.0×10^{-01}
Ra-225	8.3×10^{-15}	4.5×10^{-12}	1.4×10^{-05}	1.2×10^{-01}
Ra-226	1.5×10^{-13}	4.0×10^{-12}	1.9×10^{-05}	1.0×10^{-01}
Ra-228	8.3×10^{-14}	1.8×10^{-12}	2.6×10^{-06}	5.3×10^{-02}
Rb-81	5.9×10^{-14}	6.7×10^{-14}	5.0×10^{-11}	3.4×10^{-02}
Rb-83	4.8×10^{-14}	1.0×10^{-15}	7.1×10^{-10}	6.4×10^{-05}
Rb-84	8.3×10^{-14}	2.5×10^{-14}	1.1×10^{-09}	1.2×10^{-02}
Rb-86	8.3×10^{-15}	2.1×10^{-12}	9.6×10^{-10}	4.6×10^{-02}
Rb-87	—	1.0×10^{-15}	—	—
Rb(nat)	—	1.0×10^{-15}	—	—
Re-184	8.3×10^{-14}	1.0×10^{-15}	1.8×10^{-09}	1.6×10^{-02}
Re-184m	3.6×10^{-14}	1.0×10^{-15}	6.1×10^{-09}	2.2×10^{-02}
Re-186	1.7×10^{-15}	5.0×10^{-13}	1.1×10^{-09}	4.7×10^{-02}
Re-187	—	1.0×10^{-15}	—	—
Re-188	5.0×10^{-15}	2.9×10^{-12}	5.5×10^{-10}	5.2×10^{-02}
Re-189	3.1×10^{-15}	4.0×10^{-13}	4.3×10^{-10}	4.9×10^{-02}
Re(nat)	—	1.0×10^{-15}	—	—
Rh-99	5.6×10^{-14}	1.0×10^{-15}	8.3×10^{-10}	3.7×10^{-03}
Rh-101	2.3×10^{-14}	1.0×10^{-15}	5.0×10^{-09}	1.1×10^{-02}
Rh-102	2.0×10^{-13}	1.0×10^{-15}	1.6×10^{-08}	5.1×10^{-04}
Rh-102m	4.5×10^{-14}	1.1×10^{-13}	6.7×10^{-09}	1.5×10^{-02}
Rh-103m	2.2×10^{-16}	1.0×10^{-15}	5.0×10^{-11}	2.8×10^{-05}
Rh-105	7.1×10^{-15}	5.6×10^{-15}	3.4×10^{-10}	3.5×10^{-02}
Rn-222	1.5×10^{-13}	3.8×10^{-12}	—	—
Ru-97	2.1×10^{-14}	1.0×10^{-15}	1.1×10^{-10}	2.1×10^{-03}
Ru-103	4.5×10^{-14}	5.0×10^{-15}	2.8×10^{-09}	1.8×10^{-02}
Ru-105	7.1×10^{-14}	8.3×10^{-13}	1.8×10^{-10}	4.5×10^{-02}
Ru-106	1.9×10^{-14}	4.5×10^{-12}	6.2×10^{-08}	4.9×10^{-02}
S-35	—	1.0×10^{-15}	1.3×10^{-09}	9.4×10^{-03}
Sb-122	4.2×10^{-14}	2.3×10^{-12}	1.0×10^{-09}	4.5×10^{-02}
Sb-124	1.6×10^{-13}	1.4×10^{-12}	6.1×10^{-09}	4.0×10^{-02}
Sb-125	4.2×10^{-14}	4.0×10^{-15}	4.5×10^{-09}	2.1×10^{-02}
Sb-126	2.6×10^{-13}	7.7×10^{-13}	2.7×10^{-09}	3.9×10^{-02}
Sc-44	2.0×10^{-13}	1.6×10^{-12}	1.9×10^{-10}	4.5×10^{-02}
Sc-46	1.9×10^{-13}	1.0×10^{-15}	6.4×10^{-09}	3.3×10^{-02}
Sc-47	9.1×10^{-15}	5.9×10^{-15}	7.0×10^{-10}	3.9×10^{-02}
Sc-48	3.0×10^{-13}	1.1×10^{-12}	1.1×10^{-09}	4.3×10^{-02}
Se-75	3.4×10^{-14}	1.0×10^{-15}	1.4×10^{-09}	2.8×10^{-03}

Radionuclide	\dot{e}_{pt} (a) (Sv·Bq ⁻¹ ·h ⁻¹)	\dot{e}_{β} (b) (Sv·Bq ⁻¹ ·h ⁻¹)	e_{inh} (c) (Sv·Bq ⁻¹)	\dot{h}_{skin} (d) (Sv·m ² ·TBq ⁻¹ ·s ⁻¹)
Se-79	—	1.0×10^{-15}	2.9×10^{-09}	1.2×10^{-02}
Si-31	1.0×10^{-16}	1.7×10^{-12}	8.0×10^{-11}	4.7×10^{-02}
Si-32	—	1.0×10^{-15}	1.1×10^{-07}	1.7×10^{-02}
Sm-145	7.7×10^{-15}	1.0×10^{-15}	1.5×10^{-09}	2.8×10^{-05}
Sm-147	—	—	—	—
Sm-151	1.0×10^{-16}	1.0×10^{-15}	3.7×10^{-09}	2.8×10^{-05}
Sm-153	5.9×10^{-15}	1.1×10^{-13}	6.1×10^{-10}	4.5×10^{-02}
Sn-113	2.7×10^{-14}	1.0×10^{-15}	2.5×10^{-09}	1.7×10^{-02}
Sn-117m	1.4×10^{-14}	1.0×10^{-15}	2.3×10^{-09}	7.0×10^{-02}
Sn-119m	1.6×10^{-15}	1.0×10^{-15}	2.0×10^{-09}	2.8×10^{-05}
Sn-121m	7.0×10^{-16}	1.0×10^{-15}	4.2×10^{-09}	3.3×10^{-02}
Sn-123	6.3×10^{-16}	1.3×10^{-12}	7.7×10^{-09}	4.5×10^{-02}
Sn-125	2.8×10^{-14}	2.7×10^{-12}	3.0×10^{-09}	4.5×10^{-02}
Sn-126	1.5×10^{-13}	1.7×10^{-12}	2.7×10^{-08}	7.7×10^{-02}
Sr-82	1.0×10^{-13}	4.2×10^{-12}	1.0×10^{-08}	4.7×10^{-02}
Sr-83	7.7×10^{-14}	3.7×10^{-13}	3.4×10^{-10}	1.3×10^{-02}
Sr-85	4.8×10^{-14}	1.0×10^{-15}	7.7×10^{-10}	3.3×10^{-04}
Sr-85m	1.9×10^{-14}	1.0×10^{-15}	5.0×10^{-11}	1.5×10^{-03}
Sr-87m	3.0×10^{-14}	1.0×10^{-15}	5.0×10^{-11}	8.5×10^{-03}
Sr-89	1.0×10^{-16}	1.6×10^{-12}	7.5×10^{-09}	4.6×10^{-02}
Sr-90	1.0×10^{-16}	3.1×10^{-12}	1.5×10^{-07}	8.8×10^{-02}
Sr-91	6.6×10^{-14}	3.3×10^{-12}	4.1×10^{-10}	4.6×10^{-02}
Sr-92	1.2×10^{-14}	9.1×10^{-13}	4.2×10^{-10}	8.9×10^{-02}
T(H-3)	—	1.0×10^{-15}	5.0×10^{-11}	—
Ta-178 (2.2 h)	9.1×10^{-14}	1.0×10^{-15}	6.9×10^{-11}	3.4×10^{-02}
Ta-179	3.2×10^{-15}	1.0×10^{-15}	5.2×10^{-10}	2.8×10^{-05}
Ta-182	1.1×10^{-13}	7.7×10^{-14}	9.7×10^{-09}	5.2×10^{-02}
Tb-149	1.2×10^{-13}	2.2×10^{-14}	4.3×10^{-09}	1.3×10^{-02}
Tb-157	3.2×10^{-16}	1.0×10^{-15}	1.1×10^{-09}	2.8×10^{-05}
Tb-158	7.1×10^{-14}	6.3×10^{-15}	4.3×10^{-08}	1.5×10^{-02}
Tb-160	1.0×10^{-13}	4.3×10^{-13}	6.6×10^{-09}	4.8×10^{-02}
Tb-161	4.0×10^{-15}	4.2×10^{-15}	1.2×10^{-09}	3.9×10^{-02}
Tc-95m	6.7×10^{-14}	1.0×10^{-15}	8.7×10^{-10}	2.3×10^{-03}
Tc-96	2.3×10^{-13}	1.0×10^{-15}	7.1×10^{-10}	2.0×10^{-04}
Tc-96m	2.3×10^{-13}	1.0×10^{-15}	7.0×10^{-10}	2.0×10^{-04}
Tc-97	1.3×10^{-15}	1.0×10^{-15}	—	—
Tc-97m	1.2×10^{-15}	1.0×10^{-15}	3.1×10^{-09}	1.9×10^{-02}
Tc-98	1.3×10^{-13}	1.0×10^{-15}	—	4.1×10^{-02}
Tc-99	—	1.0×10^{-15}	—	3.1×10^{-02}
Tc-99m	1.0×10^{-14}	1.0×10^{-15}	5.0×10^{-11}	6.5×10^{-03}
Te-121	5.6×10^{-14}	1.0×10^{-15}	3.9×10^{-10}	2.8×10^{-04}
Te-121m	2.0×10^{-14}	1.0×10^{-15}	4.2×10^{-09}	1.1×10^{-02}
Te-123m	1.3×10^{-14}	1.0×10^{-15}	3.9×10^{-09}	2.4×10^{-02}

Radionuclide	\dot{e}_{pt} (a)	\dot{e}_{β} (b)	e_{inh} (c)	\dot{h}_{skin} (d)
	(Sv·Bq ⁻¹ ·h ⁻¹)	(Sv·Bq ⁻¹ ·h ⁻¹)	(Sv·Bq ⁻¹)	(Sv·m ² ·TBq ⁻¹ ·s ⁻¹)
Te-125m	5.0×10^{-15}	1.0×10^{-15}	3.3×10^{-09}	3.1×10^{-02}
Te-127	4.5×10^{-16}	5.3×10^{-14}	1.2×10^{-10}	4.2×10^{-02}
Te-127m	2.0×10^{-15}	5.3×10^{-14}	7.2×10^{-09}	5.6×10^{-02}
Te-129	5.9×10^{-15}	1.5×10^{-12}	5.0×10^{-11}	4.6×10^{-02}
Te-129m	7.7×10^{-15}	1.2×10^{-12}	6.3×10^{-09}	6.3×10^{-02}
Te-131m	1.3×10^{-13}	8.3×10^{-13}	1.1×10^{-09}	5.7×10^{-02}
Te-132	2.0×10^{-13}	2.0×10^{-12}	2.2×10^{-09}	6.6×10^{-02}
Th-227	9.1×10^{-15}	1.0×10^{-15}	9.6×10^{-06}	5.9×10^{-03}
Th-228	1.3×10^{-13}	1.9×10^{-12}	3.9×10^{-05}	1.0×10^{-01}
Th-229	8.1×10^{-15}	1.0×10^{-15}	9.9×10^{-05}	1.6×10^{-02}
Th-230	1.4×10^{-16}	1.0×10^{-15}	4.0×10^{-05}	—
Th-231	2.6×10^{-15}	1.0×10^{-15}	3.1×10^{-06}	2.3×10^{-02}
Th-232	8.3×10^{-14}	1.0×10^{-15}	—	—
Th-234	2.4×10^{-15}	3.3×10^{-12}	7.3×10^{-09}	5.6×10^{-02}
Th(nat)	2.2×10^{-13}	3.7×10^{-12}	—	—
Ti-44	2.1×10^{-13}	1.6×10^{-12}	1.2×10^{-07}	4.5×10^{-02}
Tl-200	1.2×10^{-13}	1.0×10^{-15}	1.4×10^{-10}	3.9×10^{-03}
Tl-201	8.3×10^{-15}	1.0×10^{-15}	4.7×10^{-11}	7.0×10^{-03}
Tl-202	4.3×10^{-14}	1.0×10^{-15}	2.0×10^{-10}	1.7×10^{-03}
Tl-204	1.0×10^{-16}	1.0×10^{-13}	4.4×10^{-10}	4.0×10^{-02}
Tm-167	1.4×10^{-14}	1.0×10^{-15}	1.1×10^{-09}	3.4×10^{-02}
Tm-170	5.0×10^{-16}	3.8×10^{-13}	6.6×10^{-09}	4.5×10^{-02}
Tm-171	1.0×10^{-16}	1.0×10^{-15}	1.3×10^{-09}	2.7×10^{-04}
U-230 (F)	1.9×10^{-15}	1.0×10^{-15}	3.6×10^{-07}	9.0×10^{-03}
U-230 (M)	1.9×10^{-15}	1.0×10^{-15}	1.2×10^{-05}	9.0×10^{-03}
U-230 (S)	1.9×10^{-15}	1.0×10^{-15}	1.5×10^{-05}	9.0×10^{-03}
U-232 (F)	2.1×10^{-16}	1.0×10^{-15}	4.0×10^{-06}	1.5×10^{-04}
U-232 (M)	2.1×10^{-16}	1.0×10^{-15}	7.2×10^{-06}	1.5×10^{-04}
U-232 (S)	2.1×10^{-16}	1.0×10^{-15}	3.5×10^{-05}	1.5×10^{-04}
U-233 (F)	1.3×10^{-16}	1.0×10^{-15}	5.7×10^{-07}	—
U-233 (M)	1.3×10^{-16}	1.0×10^{-15}	3.2×10^{-06}	—
U-233 (S)	1.3×10^{-16}	1.0×10^{-15}	8.7×10^{-06}	—
U-234 (F)	1.7×10^{-16}	1.0×10^{-15}	5.5×10^{-07}	—
U-234 (M)	1.7×10^{-16}	1.0×10^{-15}	3.1×10^{-06}	—
U-234 (S)	1.7×10^{-16}	1.0×10^{-15}	8.5×10^{-06}	—
U-235 (F)	1.6×10^{-14}	1.0×10^{-15}	—	—
U-235 (M)	1.6×10^{-14}	1.0×10^{-15}	—	—
U-235 (S)	1.6×10^{-14}	1.0×10^{-15}	—	—
U-236 (F)	1.5×10^{-16}	1.0×10^{-15}	—	—
U-236 (M)	1.5×10^{-16}	1.0×10^{-15}	2.9×10^{-06}	—
U-236 (S)	1.5×10^{-16}	1.0×10^{-15}	7.9×10^{-06}	—
U-238 (F)	1.3×10^{-16}	1.0×10^{-15}	—	—
U-238 (M)	1.3×10^{-16}	1.0×10^{-15}	—	—
U-238 (S)	1.3×10^{-16}	1.0×10^{-15}	—	—
U(nat)	1.6×10^{-13}	7.9×10^{-12}	—	—
U(dep)	2.2×10^{-15}	3.1×10^{-12}	—	—

Radionuclide		\dot{e}_{pt} (a)	\dot{e}_{β} (b)	e_{inh} (c)	\dot{h}_{skin} (d)
		(Sv·Bq ⁻¹ ·h ⁻¹)	(Sv·Bq ⁻¹ ·h ⁻¹)	(Sv·Bq ⁻¹)	(Sv·m ² ·TBq ⁻¹ ·s ⁻¹)
V-48		2.6×10^{-13}	3.3×10^{-13}	2.3×10^{-09}	2.5×10^{-02}
V-49		1.0×10^{-16}	1.0×10^{-15}	5.0×10^{-11}	2.8×10^{-05}
W-178		1.1×10^{-14}	1.0×10^{-15}	7.6×10^{-11}	6.1×10^{-03}
W-181		3.8×10^{-15}	1.0×10^{-15}	5.0×10^{-11}	5.2×10^{-05}
W-185		1.0×10^{-16}	1.0×10^{-15}	1.4×10^{-10}	3.4×10^{-02}
W-187		4.5×10^{-14}	4.8×10^{-13}	2.0×10^{-10}	4.5×10^{-02}
W-188		5.0×10^{-15}	2.7×10^{-12}	1.1×10^{-09}	7.9×10^{-02}
Xe-122	(*)	9.1×10^{-14}	2.5×10^{-12}	—	—
Xe-123	(*)	5.6×10^{-14}	1.0×10^{-13}	—	—
Xe-127	(*)	2.6×10^{-14}	1.0×10^{-15}	—	—
Xe-131m	(*)	2.6×10^{-15}	1.0×10^{-15}	—	—
Xe-133	(*)	4.8×10^{-15}	1.0×10^{-15}	—	—
Xe-135	(*)	2.2×10^{-14}	2.9×10^{-13}	—	—
Y-87		7.1×10^{-14}	1.0×10^{-15}	4.0×10^{-10}	8.7×10^{-03}
Y-88		2.3×10^{-13}	1.0×10^{-15}	4.1×10^{-09}	1.3×10^{-04}
Y-90		1.0×10^{-16}	3.1×10^{-12}	1.5×10^{-09}	4.7×10^{-02}
Y-91		3.2×10^{-16}	1.7×10^{-12}	8.4×10^{-09}	4.6×10^{-02}
Y-91m		5.0×10^{-14}	1.0×10^{-15}	5.0×10^{-11}	2.3×10^{-03}
Y-92		2.3×10^{-14}	4.5×10^{-12}	2.0×10^{-10}	4.9×10^{-02}
Y-93		7.7×10^{-15}	3.8×10^{-12}	4.3×10^{-10}	4.8×10^{-02}
Yb-169		2.9×10^{-14}	1.0×10^{-15}	2.8×10^{-09}	2.7×10^{-02}
Yb-175		3.7×10^{-15}	1.0×10^{-15}	7.0×10^{-10}	3.2×10^{-02}
Zn-65		5.3×10^{-14}	1.0×10^{-15}	2.9×10^{-09}	6.7×10^{-04}
Zn-69		1.0×10^{-16}	3.1×10^{-13}	5.0×10^{-11}	4.5×10^{-02}
Zn-69m		2.9×10^{-14}	2.5×10^{-13}	2.9×10^{-10}	4.7×10^{-02}
Zr-88		3.8×10^{-14}	1.0×10^{-15}	3.5×10^{-09}	1.3×10^{-03}
Zr-93			1.0×10^{-15}	-	
Zr-95		5.6×10^{-14}	2.2×10^{-15}	5.5×10^{-09}	3.3×10^{-02}
Zr-97		1.1×10^{-13}	2.7×10^{-12}	1.0×10^{-09}	4.9×10^{-02}

TABLE II.3. SPECIFIC ACTIVITY VALUES FOR URANIUM AT VARIOUS LEVELS OF ENRICHMENT

Mass per cent of U-235 present in uranium mixture	Specific activity ^{a,b}	
	Bq/g	Ci/g
0.45	1.8×10^4	5.0×10^{-7}
0.72 (natural)	2.6×10^4	7.06×10^{-7}
1.0	2.8×10^4	7.6×10^{-7}
1.5	3.7×10^4	1.0×10^{-6}
5.0	1.0×10^5	2.7×10^{-6}
10.0	1.8×10^5	4.8×10^{-6}
20.0	3.7×10^5	1.0×10^{-5}
35.0	7.4×10^5	2.0×10^{-5}
50.0	9.3×10^5	2.5×10^{-5}
90.0	2.2×10^6	5.8×10^{-5}
93.0	2.6×10^6	7.0×10^{-5}
95.0	3.4×10^6	9.1×10^{-5}

^a The values of the specific activity include the activity of U-234, which is concentrated during the enrichment process; these values do not include any daughter product contribution. The values are for the material originating from natural uranium enriched by a gaseous diffusion method.

^b If the origin of the material is not known, the specific activity should be either measured or calculated by using isotopic ratio data.

REFERENCE TO APPENDIX II

- [II.1] INTERNATIONAL COMMISSION ON RADIATION PROTECTION, Nuclear Decay Data for Dosimetric Calculations, ICRP Publication 107, Ann. ICRP 38, 2008.

Appendix III

EXAMPLE CALCULATIONS FOR ESTABLISHING MINIMUM SEGREGATION DISTANCES

INTRODUCTION

III.1. Segregation is used in the Transport Regulations for transport and storage in transit in three ways:

- (a) To separate radioactive material packages from places regularly occupied by people and provide adequate radiation protection (para. 562(a) and (b));
- (b) To separate radioactive material packages from packages of undeveloped photographic film and provide protection of the film from inadvertent exposure or fogging (para. 562(c));
- (c) To separate radioactive material packages from packages of other dangerous goods (paras 506 and 562(d)).

III.2. This appendix provides guidance on one way of developing criteria for segregating radioactive material packages from areas regularly occupied by workers and members of the public. A similar procedure can be used for developing criteria for protection of undeveloped film. A method for segregating radioactive material packages from other dangerous goods is briefly summarized in para. 562.11.

III.3. Generally, modal transport authorities accomplish segregation for radiation protection by establishing tables of minimum segregation distances, which are based upon the dose criteria in para. 562 of the Transport Regulations (see also footnotes b and c in Table 11 in the Transport Regulations for segregation distances for criticality safety purpose).

III.4. The method for establishing segregation distances outlined below is conservative in many ways. For example, the dose criteria in para. 562 are applied at the boundary to a regularly occupied area. Since individuals will move around within the occupied area during the period when radioactive material packages are present, their resultant exposure will be less than these dose criteria [III.1]. The dose rates used in the calculations are based on the TI of a package or on the summation of the TIs in an array of packages. Thus, for arrays of packages, self-shielding within the array is not considered, and actual dose rates will be lower than those upon which the calculations are based.

III.5. To establish minimum segregation distances by this method, it is first necessary to develop a model of transport conditions for a given mode of transport. Numerous variables need to be considered in the development of the model. These considerations are well known and have been documented in previous calculations made for air transport [III.2, III.3] and for sea transport [III.2]. Important parameters in such a model include:

- (a) The maximum annual travel periods (MATPs) for crew and for members of the public (i.e. the representative person).

- (b) The radioactive traffic factor (RTF), defined as the ratio of the annual number of journeys made with category II-YELLOW and category III-YELLOW packages of radioactive material⁵ to the annual total of all journeys.
- (c) The maximum annual exposure times (MAETs) for both crew and members of the public, which are the relevant MATP multiplied by the appropriate RTF, i.e.:

$$\text{MAET (h/year)} = \text{MATP (h/year)} \times \text{RTF} \quad (\text{III.1})$$

- (d) The applicable dose values (DVs) from para. 562 for crew and members of the public.
- (e) The reference dose rates (RDRs) for crew and members of the public, which are used as the basis for establishing the minimum segregation distances and are derived by dividing the dose values by the applicable maximum annual exposure time, i.e.:

$$\text{RDR (mSv/h)} = \text{DV (mSv/year)} / \text{MAET (h/year)} \quad (\text{III.2})$$

III.6. The following example shows how segregation distances may be determined for passenger aircraft and for cargo aircraft. This example is based on a particular set of assumptions and calculational techniques; other calculational techniques are also possible. Three possible configurations are considered, as follows:

- (a) Below main deck stowage in a passenger aircraft of radioactive material packages in a single group;
- (b) Below main deck stowage in a passenger aircraft of radioactive material packages in multiple groups with prescribed spacing distances between groups;
- (c) Main deck stowage on either a combined cargo and passenger aircraft (known in the airline industry as a 'combi' aircraft) or a cargo aircraft.

III.7. In the following calculations, all packages and groups of packages are treated as single point sources for which dose rates can be described by the inverse square relationship. Consideration of the details of package dimensions and of the stowage configurations will generally lead to a small decrease in the segregation distance required. Thus, treating all groups of packages as single point sources is conservative.

BELOW MAIN DECK STOWAGE OF ONE GROUP OF PACKAGES IN PASSENGER AIRCRAFT

III.8. In a typical passenger aircraft, packages are loaded in a cargo compartment directly below the passenger compartment. The highest dose rate would be experienced by a passenger located in a seat directly above a package or group of packages of radioactive material. All other passengers would be exposed at lower levels. This situation is depicted in Fig. III.1.

⁵ Category I-WHITE packages are excluded from this because they present no essential radiation exposure hazard.

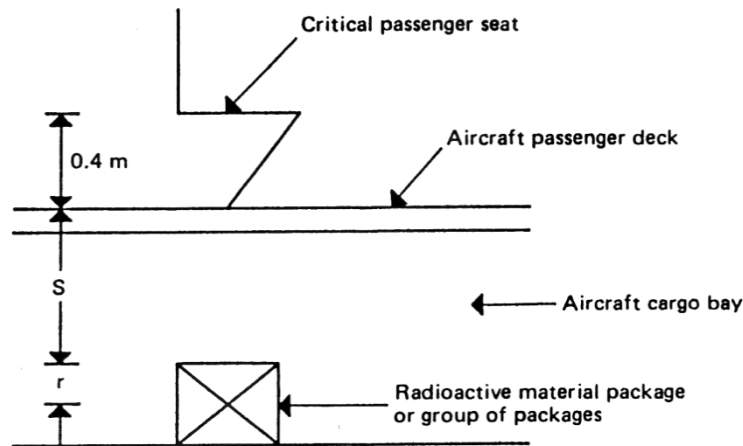

FIG. III.1. Typical configuration of passenger and cargo in passenger aircraft, used for determining the segregation distance, S .

III.9. The actual minimum distance (AMD) of segregation needed between a source within a package (or group of packages) and the point of interest (representing a passenger) on a typical aircraft will be the sum of the required segregation distance (S , in metres) between the package and the passenger compartment boundary, the height of the seat (although the actual seat height in most aircraft would be approximately 0.5 m, it is conservatively assumed to be 0.4 m here) and the radius of the package (r , in metres):

$$\text{AMD} = S + 0.4 + r \quad (\text{III.3})$$

III.10. The TI provides an accurate measure of the maximum dose rate at 1 m from the package surface. The TI needs to be divided by a factor of 100 to obtain the dose rate in mSv/h. Hence, the inverse square law gives:

$$\text{RDR} = (\text{TI}/100)(\text{TF}_f)(1.0 + r)^2/(\text{AMD})^2 \quad (\text{III.4})$$

where

RDR is the reference dose rate at seat height (mSv/h);

TI is the transport index;

TF_f is the transmission factor of the passenger compartment floor, the fraction of radiation that passes through the aircraft structures between the source and the passenger (dimensionless);

r is the radius of a package or a collection of packages (half of the minimum dimension) (m);

AMD is the actual minimum distance to the dose point (m).

III.11. Substitution of Eq. (III.3) into Eq. (III.4) yields:

$$\text{RDR} = (\text{TI}/100)(\text{TF}_f)(1.0 + r)^2 / (S + 0.4 + r)^2 \quad (\text{III.5})$$

III.12. Solving for S, gives:

$$S = [(TI \times TF_f)/(100 \times RDR)]^{1/2} (1.0 + r) - (r + 0.4) \quad (III.6)$$

III.13. The transmission factor (TF_f) varies with the energy of the radiation emitted from the package and the aircraft floor construction. Typical transmission factors range from 0.7 to 1.0. The combinations of TI, transmission factor and package size shown in Table III.1 were selected as conservative but realistic models.

TABLE III.1. TRANSMISSION FACTORS

Transport index (TI)	Transmission factor (TF_f)	Package radius (r) (m)
0–1.0	1.0	0.05
1.1–2.0	0.8	0.1
2.1–50	0.7	0.4

III.14. The reference dose rate (RDR) is determined from Eqs (III.1, III.2). It is assumed that RTF is 1 in 10 [III.4]. It is estimated that regular travellers could fly 500 h each year, hence the MATP for the representative person is assumed to equal 500 h/year. Thus, from Eq. (III.1):

$$MAET = (500 \text{ h/year}) \times (0.1) = 50 \text{ h/year}$$

III.15. The applicable DV for a passenger, from para. 562(b) of the Transport Regulations, is 1 mSv/year, and thus the applicable RDR, from Eq. (III.2), is:

$$RDR = (1 \text{ mSv/year})/(50 \text{ h/year}) = 0.02 \text{ mSv/h}$$

III.16. For below main deck stowage on passenger aircraft, the exposure to pilots should be minimal because of the location of the cockpit relative to the cargo areas.

III.17. With these assumptions, Eq. (III.6) is used to calculate the segregation distances shown in column two of Table III.2. Also shown for comparison are the segregation values used in the ICAO Technical Instructions for the Safe Transport of Dangerous Goods by Air [III.5]. For use in international transport organization regulations, values such as these are often rounded for convenience.

BELOW MAIN DECK STOWAGE OF MULTIPLE GROUPS OF PACKAGES IN PASSENGER AIRCRAFT

III.18. It should be noted that the calculated vertical segregation distance of 1.05 m for a single package or group of packages with a TI of 5 can be obtained in most aircraft, but that for many aircraft, it would be impossible to obtain a vertical segregation distance above 1.6 m. This would limit the total TI in a group of packages that could be placed on a passenger aircraft. To increase the total TI that can be carried on a passenger aircraft, it would be necessary to space the packages or groups of packages within the belly cargo compartments of the aircraft. A configuration of five groups of packages, each having a different total TI value, with equal

spacing distance, S', between groups, is depicted in Fig. III.2. The highest dose rate for passengers would be at the seat directly above the centre group of packages.

TABLE III.2. VARIATION OF SEGREGATION DISTANCE WITH TRANSPORT INDEX FOR A SINGLE GROUP OF PACKAGES STOWED BELOW THE MAIN DECK OF A PASSENGER AIRCRAFT

Total of TIs for packages in the group	Vertical segregation distance (top of group of packages to floor of main deck (m))	
	Calculated here ^a	In 2017–2018 ICAO Technical Instructions ^b
1.0	0.29	0.30
2.0	0.48	0.50
3.0	0.63	0.70
4.0	0.86	0.85
5.0	1.05	1.00
6.0	1.23	1.15
7.0	1.39	1.30
8.0	1.54	1.45
9.0	1.68	1.55
10.0	1.82	1.65

^a Calculated using Eq. (III.6) and assumptions outlined in this appendix.

^b ICAO Technical Instructions for the Safe Transport of Dangerous Goods by Air [III.5].

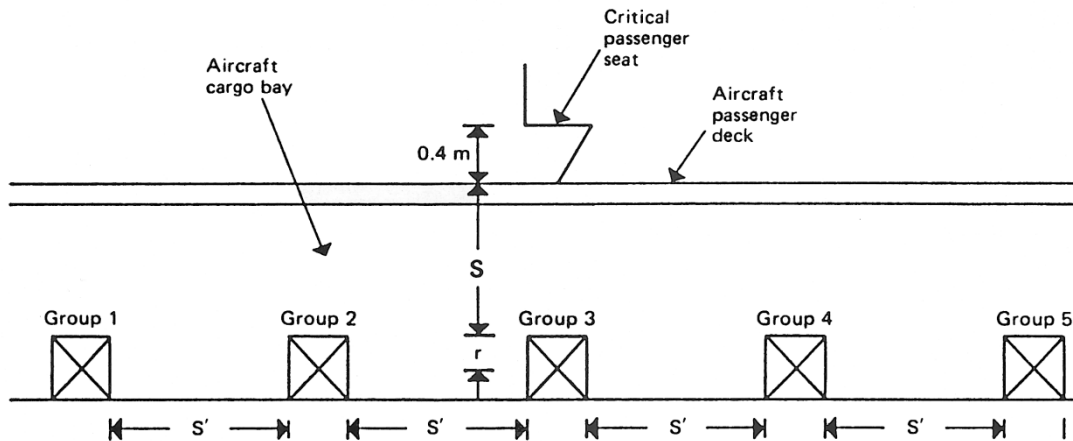

FIG. III.2. Typical configuration of passenger and special cargo in passenger aircraft, used for determining the segregation distance, S , and spacing distance, S' .

III.19. For a configuration such as that shown in Fig. III.2, the inverse square law gives:

$$RDR = TF_f \sum_{i=1}^5 (TI_i/100)(1.0+r_i)^2 / (AMD_i)^2 \quad (III.7)$$

III.20. It is assumed that:

$$TI_i = 4, \quad i = 1 \text{ to } 5$$

$$r_i = 0.4 \text{ m}, \quad i = 1 \text{ to } 5$$

$$TF_f = 0.7$$

$RDR = 0.02 \text{ mSv/h}$. It is noted that:

$$AMD_1 = AMD_5 = \sqrt{(r+S+0.4)^2 + (4r+S')^2} \quad (III.8)$$

$$AMD_2 = AMD_4 = \sqrt{(r+S+0.4)^2 + (2r+S')^2} \quad (III.9)$$

$$AMD_3 = r+S+0.4 \quad (III.10)$$

III.21. Equations (III.7) - (III.10) combine to give one equation with two unknowns, S and S' . Various combinations of S and S' would allow a consignment of packages having a total TI of

20 to be carried with a segregation distance, S , of less than 2.9 m. For example, placing the five groups, each with a total TI of 4, as shown in Fig. III.2, a segregation distance S of 1.6 m with a spacing distance S' of 2.11 m would give a maximum dose rate at seat height of 0.02 mSv/h. Thus, various combinations of segregation and spacing would safely control the radiation exposure of passengers for large TI consignments.

MAIN DECK STOWAGE ON COMBI OR CARGO AIRCRAFT

III.22. For this configuration, all parameters previously assumed are used, except TF_w (transmission factor for the wall of an occupied compartment) is assumed to be greater than or equal to 0.8.

III.23. For the crew, the following assumptions⁶ are made:

$$MATP = 1000 \text{ h/year}$$

$$RTF = 1/4$$

$$MAET = (1000 \text{ h/year}) \times (1/4) = 250 \text{ h/year}$$

$$DV = 5 \text{ mSv/year (from para. 562(a) of the Transport Regulations)}$$

$$RDR = (5 \text{ mSv/year}) / (250 \text{ h/year}) = 0.02 \text{ mSv/h}$$

III.24. The MATP and MAET values used for passengers in passenger aircraft are also used here. With these assumptions, the calculations for passengers in a combi and for crew in a cargo aircraft will result in the same segregation distances.

III.25. The situation for combi or cargo aircraft is depicted in Fig. III.3. The minimum horizontal distance between the seat back of a seated person and the inside wall of the occupied compartment is also assumed to be 0.4 m. This is probably a conservative value because, if the cargo is forward, the passenger's feet will be against the partition, and if the cargo is aft, there will usually be instruments, a galley, toilets or at least luggage or seat-reclining space between the partition and the rear seat. For this situation, Eq. (III.3) applies for AMD, and S can be obtained from:

$$S = [(TI \times TF_w) / (100 \times RDR)]^{1/2} (1 + r) - (r + 0.4) \quad \text{(III.11)}$$

⁶ The values of MATP and RTF assumed here for crew members have not been verified for actual flight situations.

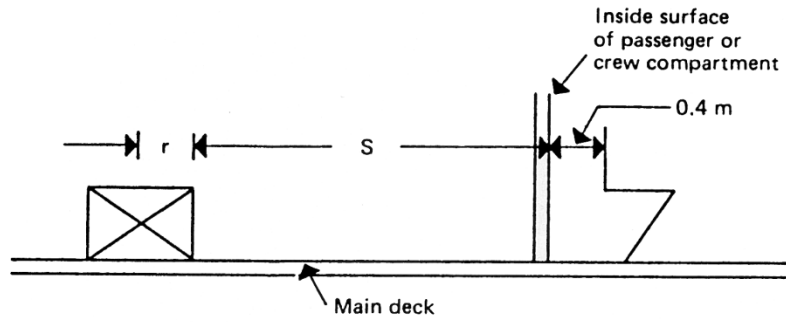

FIG. III.3. Typical configuration of main deck stowage on a combi or cargo aircraft.

III.26. The calculated segregation distances for combi and cargo aircraft are shown in Table III.3.

TABLE III.3. VARIATION OF SEGREGATION DISTANCE WITH TRANSPORT INDEX FOR MAIN DECK STOWAGE ON A COMBI OR CARGO AIRCRAFT

Total of TIs for packages in the group	Horizontal segregation distance (forward face of group of packages to inside wall of occupied compartment (m))
1.0	0.29
2.0	0.48
5.0	1.18
10.0	2.00
20.0	3.16
30.0	4.05
40.0	4.80
50.0	5.46
100.0	8.05
150.0	10.04
200.0	11.72

REFERENCES TO APPENDIX III

- [III.1] WILSON, C.K., The air transport of radioactive materials, *Radiat. Prot. Dosim.* **48** 1 (1993) 129–133.
- [III.2] GIBSON, R., *The Safe Transport of Radioactive Materials*, Pergamon Press, Oxford and New York (1966)
- [III.3] UNITED STATES ATOMIC ENERGY COMMISSION, *Recommendations for Revising Regulations Governing the Transportation of Radioactive Material in Passenger Aircraft* (July 1994) (available at the Nuclear Regulatory Commission's Public Document Room, Washington, DC).
- [III.4] GELDER, R., *Radiological Impact of the Normal Transport of Radioactive Materials by Air*, Rep. NRPB M219, National Radiological Protection Board, Chilton, UK (1990).
- [III.5] INTERNATIONAL CIVIL AVIATION ORGANIZATION, *Technical Instructions for the Safe Transport of Dangerous Goods by Air*, 2017–2018 Edition, ICAO, Montreal (2017).

Appendix IV

PACKAGE STOWAGE AND RETENTION DURING TRANSPORT

INTRODUCTION

IV.1. For radioactive packages to be transported safely, the Transport Regulations require packages to be restrained from movement within or on the conveyance during the transport operation. The relevant requirements of the Transport Regulations apply in the following ways:

- Paragraph 564: It is required that the consignments are securely stowed— this can be ensured by a variety of retention systems (see below).
- Paragraph 607: It is required that each package is designed with due consideration being given to its retention systems for each intended mode of transport.
- Paragraph 612: It is required that retention systems that are not part of the package do not reduce the safety of the package.
- Paragraph 613: It is required that the components of the package, its contents and their respective retention systems are designed so that the package integrity will not be affected during routine conditions of transport.
- Paragraph 638: It is required that the integrity of the package is not impaired by the stresses imposed on the package or its attachment points by the tie-downs or other retention systems in either normal or accident transport conditions.

Some aspects relating to these paragraphs are noted in the respective advisory paragraphs in the main text of this publication, but additional detail is contained in this appendix and in Refs [IV.1–IV.36].

IV.2. This appendix provides guidance on considering the effects of the retention system loads applied to the package during routine conditions of transport. It describes possible methods for demonstrating compliance with package design requirements. The package will include the attachment points but not the remainder of the retention system. Other components of the retention system, which are not part of the package, are addressed by modal and national requirements.

IV.3. The inertial forces that act on the packages during routine conditions of transport (see para 106) might be caused by, for example:

- (a) Uneven road or track;
- (b) Vibration;
- (c) Braking and accelerations;
- (d) Direction changes;
- (e) Rail shunting (when permitted);
- (f) Motions of a ship in heavy seas;
- (g) Turbulence in air transport.

The inertial forces that act on the packages during the following circumstances are not considered as routine conditions of transport and are not addressed in this appendix:

- (a) Minor impacts with vehicles and obstacles;
- (b) Rail shunting (when not permitted);
- (c) Very exceptional seas;
- (d) Emergency landings in air transport.

IV.4. Package retention systems have to be designed to perform in a predictable manner under all conditions of transport. However, in normal or accident conditions of transport (see para 106), the package is permitted, and may be required as part of the design, to separate from the conveyance by the breakage or designed release of its restraint in order to preserve package integrity.

DEFINITIONS AND GENERAL REMARKS

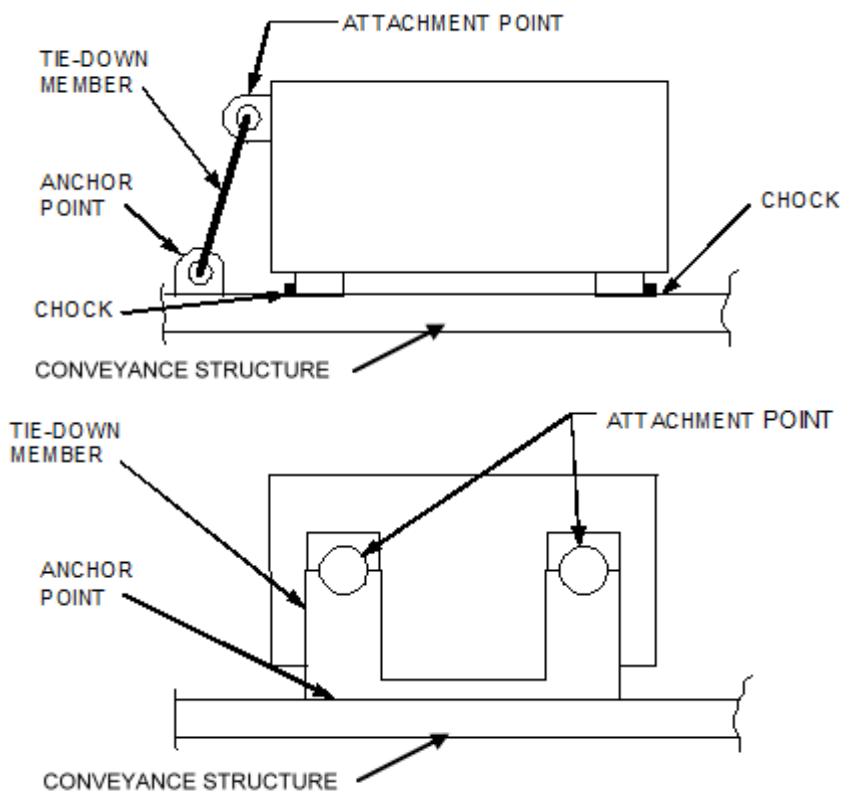

FIG. IV.1. Retention system components

IV.5. Typical retention systems may consist of, among other items, tensile tie-downs or lashings, nets, trunnions on the package secured to bearers on (or flanges bolted to) a transport frame or conveyance, ISO twistlocks, chocks or stillages. Some of these methods of retention may be combined. Figure IV.1 shows examples of components of retention systems.

IV.6. For the purposes of the guidance in this appendix, the following definitions of terms apply:

Attachment point:	A fitting on the package to which a retention member is secured.
Anchor point:	A fitting on the conveyance to which a retention member is secured.
Chock:	A fitting secured to the conveyance for the purpose of resisting horizontal inertial forces.
Dunnage:	Loose material used to protect cargo in a ship's hold, or padding in a shipping container.
Retention:	The use of mechanical devices to restrain a package and prevent movement within or on a conveyance during routine transport..
Retention member:	A mechanical device, such as dunnage, a brace, a block, a tie-down member, a stillage, a cargo net, used as a component of a retention system.
Retention system:	An assembly or arrangement of retention members, attachment points and anchor points, as applicable, designed for package retention.
Stillage:	A framework fitted to a conveyance for carrying unsecured packages.
Stowage:	The emplacement within or on a conveyance of a radioactive material package relative to other cargo (both radioactive and non-radioactive).
Tie-down member:	A type of retention member (e.g. wire rope, chain or tie-rod) that connects one or more attachment points to one or more anchor points.
Tie-down system:	A type of retention system consisting of one or more attachment points, tie-down members, and anchor points.

IV.7. Attachment points are integral parts of the package. All other parts of the retention system such as tie-down members (e.g. lashings, ropes, chains or straps), anchor points and chocks, are not part of the package.

IV.8. The methods of retention should not cause the package to be damaged, or generate stresses in the components of the package or its attachment points beyond the yield stress of the constituent materials, during routine conditions of transport.

IV.9. The consignor and carrier have the responsibility to ensure that the transport of the package is conducted in compliance with the regulatory and transport modal requirements. Persons involved in tie-down should be adequately trained and qualified commensurate with their responsibilities. The design of some tie-down members requires pre-tensioning to avoid slackening during use. In this case, tension in tie-down members should be maintained throughout the journey (e.g. through checking and tightening as required). Potential loosening by vibration during transit should be taken into account (e.g. by using vibration resistant connections). Frequently, larger and heavier packages are secured to the conveyance by means of a dedicated method of retention. Such retention members should be consistent with the package design. Operating, handling, and maintenance instructions should be developed for the use of any dedicated retention member.

IV.10. Training for persons involved in the retention of packages of radioactive material should be commensurate with their tasks. Typical training programmes should include:

- Legal responsibilities of the parties involved (e.g. consignors, carriers) in retention operations for the intended modes of transport;
- Specific hazards presented by packages of radioactive material related to retention operations (see para 311);
- Forces induced by the transport on the packages for the intended modes of transport;
- Requirements for securing packages specific to each intended mode of transport;
- Description of the conveyance and equipment (e.g. anchor points) for the intended modes of transport;
- Methods of retention, associated equipment, design and justification of the retention of a package in accordance with the applicable rules;
- Stowage instructions;
- Checks and controls of retention members, attachment points and anchor points of the package and the conveyance, respectively, prior to the retention operations and associated criteria for acceptance;
- Implementation of the different methods of retention and securing (practical application);
- Checking correct stowage before and during carriage.

IV.11. This appendix does not focus on handling loads. However, when an attachment point is used both for lifting and retention then the lifting operation loads, including snatch lifting loads (see para 608), should be taken into account in the design.

DEMONSTRATING COMPLIANCE THROUGH ANALYSIS

IV.12. Structural analysis of attachment points under routine conditions of transport should include strength analysis and fatigue analysis of relevant components. If necessary, issues such as brittle fracture and structural stability should be considered. The temperature range of the attachment points under routine conditions of transport should be taken into account.

IV.13. Structural analysis of attachment points can generally be performed by analytical methods (e.g. beam theory) or by numerical methods (e.g. finite element analysis). Numerical methods lead to more detailed stress and strain results for complex structures. The accuracy of the finite element analysis is dependent on the accuracy of the input (i.e. meshing, boundary conditions, material behaviour and properties). Thus, the finite element analysis should be verified to gain the required confidence in the output. The interpretation of these detailed results depends upon the assessment technique (e.g. nominal stress, local stress or stress linearization). The analysis methods, assessment techniques and design criteria should be acceptable to the relevant competent authorities. Examples of various approaches are given in Refs [IV.25, IV.28, IV.30].

IV.14. Owing to the differences in transport infrastructures and practices, the national competent authorities and the national and international transport modal standards and regulations need to be consulted to confirm the mandatory or recommended package loads, together with any special

conditions for transport, which should be taken into account in the design of the packages. These loads are generally specified by acceleration values to represent the package inertial effects for structural analysis, and are usually applied at the package centre of gravity as equivalent quasi-static forces. The load case data may differ according to the type of structural analysis (strength analysis or fatigue analysis).

IV.15. If the design has more than two attachment points then load sharing between them should be carefully considered.

IV.16. For strength analysis of the attachment points, the acceleration values representing routine conditions of transport are given in Table IV.1. The values given in Table IV.1 are derived from different national and international standards and guidelines (Refs [IV.1–IV.3, IV.6, IV.8, IV.14, IV.27, IV.29, IV.31]), and applying a factor of 1.25, which increases the confidence that the proposed range of loading will not be exceeded. Use of these acceleration values is generally appropriate; however, for ground transport in some transit facilities (e.g. handling of packages at an airport), different values may be relevant. If a specific design code is used in the analysis, an additional safety factor consistent with the applied code may be required. If no specific design code is used, then a safety factor should be considered and justified in the analysis (e.g. see Ref [IV.36]). The forces imposed on the package are determined by multiplying the acceleration values listed in Table IV.1 by the mass of the package, and are applied at its centre of gravity. The analysis should first consider application of each directional acceleration value separately and then all combinations for each line in Table IV.1 for the relevant transport mode.

TABLE IV.1. ACCELERATION VALUES FOR STRENGTH ANALYSIS

Mode	Longitudinal	Lateral	Vertical ^a
Road	1g	-	1g down ± 0.3g ^b
	-	0.7g	1g down ± 0.3g ^b
Rail	1.3g/5g ^c	-	1g down ± 0.4g
	-	0.7g	1g down ± 0.4g
Sea/water	0.5g	-	1g down ± 1g
	0.3g	1g	1g down ± 0.6g
Air	1.3g	-	1g down
	-	1.3g	1g down
	-	-	2.5g up, 2.5g down

^a The effect of gravity is included.

^b For packages transported in vehicles lighter than 3 500 kg, higher acceleration values should be considered (Ref [IV.29]). No precise value can presently be proposed due to lack of data.

^c 1.3g should be used if wagons equipped with long-stroke shock-absorbers or if hump and fly shunting operations are explicitly excluded.

IV.17. The package designer is responsible for ensuring that the package attachment points are designed in compliance with values acceptable to the relevant competent authorities, and defined in modal requirements. Table IV.2 provides acceleration values for specific applications. For some specific package designs, there have already been agreements with many competent authorities and the transport modal organizations that different acceleration values may be used. Table IV.2 details a limited number of such packages and other examples can be found in Refs [IV.1–IV.36], in particular Refs [IV.10–IV.12]. The acceleration values given in Table IV.2 are taken from the references quoted and may not be on the same basis as Table IV.1. The original references should be referred to, as necessary, for clarification.

TABLE IV.2. ACCELERATION VALUES FOR STRENGTH ANALYSIS FOR SPECIFIC PACKAGES

Type of Package	Longitudinal	Lateral	Vertical
Certified fissile and Type B(U) or Type B(M) packages in the USA (all modes of transport) [IV.7]	10g	5g	2g
Carriage of irradiated nuclear fuel, plutonium and high level radioactive waste (INF) on sea going vessels [IV.9]	1.5g	1.5g	1g up, 2g down
Portable tanks (road, rail, inland water ways and sea) [IV.32, 33]	2g	2g	1g up, 2g down

IV.18. In addition to the strength analysis, the package designer should also take into account the effects of cyclic loads under routine conditions of transport that could lead to the failure of components of the package. For fatigue analysis, it is preferable to design the attachment point for infinite endurance but, as an alternative, it is also acceptable to determine the fatigue life of the attachment point and to control it in service (e.g. change of component after a defined service time). A detailed fatigue analysis might not be necessary if the number of load cycles applied to the attachment point do not exceed a threshold specified in the relevant design code. Acceleration values for fatigue analysis [IV.31] imparted by rail wagons are reproduced in Table IV.3. The use of these values is possible if the conditions and criteria in Ref. [IV.31] are relevant. Other acceleration values for fatigue analysis for different transport modes can be found in Ref [IV.3]. Cyclic load measurements made during transport are given in Refs [IV.18, 19, 22]. If the data in the reference are not applicable, appropriate measurement data should be provided by the package designer. Acceleration values, number of cycles, allowable stress levels and acceptable design criteria for fatigue assessment should be agreed with the relevant competent authorities. For attachment points that are also used for lifting, the lifting cycles should be included in the fatigue analysis. Fatigue analysis is not a substitute for inspection and maintenance.

TABLE IV.3. ACCELERATION VALUES FOR FATIGUE ANALYSIS

Transport mode	Longitudinal	Lateral	Vertical
Rail	± 0.3g	± 0.4g	1g down ± 0.3g

IV.19. If the package can be secured on the conveyance in more than one orientation then acceleration values in the appropriate directions should be used in the analysis (e.g. longitudinal could become lateral).

DEMONSTRATING COMPLIANCE THROUGH TESTING

IV.20. When using measured data from acceleration sensors, the cut-off frequency should be considered relative to equivalent quasi-static loads. The cut-off frequency should be selected to suit the mass, shape and dimensions of the package and the conveyance under consideration. For initial consideration, for ground transport of a package with a mass of 100 tonnes, the cut-off frequency could be of the order of 10–20 Hz [IV.8]. For smaller packages, the cut-off frequency above should be multiplied by $(100/m)^{1/3}$, where m is the mass of the package in tonnes. This initial consideration should be verified.

REFERENCES TO APPENDIX IV

- [IV.1] IMO/ILO/UNECE Code of Practice for Packing of Cargo Transport Units (CTU Code) (2014).
- [IV.2] INTERNATIONAL ORGANIZATION FOR STANDARDIZATION, Air cargo equipment – Restraint straps – Part 2: Utilization guidelines and lashing calculations, ISO 16049-2:2013 (2013).
- [IV.3] TRANSPORT CONTAINER STANDARDISATION COMMITTEE, Transport of Radioactive Material Code of Practice, Guide to the Securing/Retention of Radioactive Material Payloads and Packages During Transport, Rep. TCSC 1006, (2014).
- [IV.4] UNITED STATES DEPARTMENT OF ENERGY, Fuel Shipping Containers Tie-Down for Truck Transport, RTD Standard F8-11T, USDOE, Washington, DC (1975).
- [IV.5] OAK RIDGE NATIONAL LABORATORY, Structure Analysis of Shipping Casks, Vol. 7, Cask Tie-down Design Manual, Technical Report, Rep. ORNL-TM-1312, Oak Ridge Natl Lab., TN (1969).
- [IV.6] NATIONAL TRANSPORT COMMISSION & ROADS & TRAFFIC AUTHORITY NSW - LOAD RESTRAINT GUIDE - Guidelines and Performance Standards for the Safe Carriage of Loads on Road Vehicles – Second Edition – 2004
- [IV.7] NUCLEAR REGULATORY COMMISSION, Lifting and Tie-down Standards for All Packages, 10 CFR 71.45, US Government Printing Office, Washington, DC (2014).
- [IV.8] UNION INTERNATIONALE DES CHEMINS DE FER, Railway Technical Publications, Appendix II, Vol. 1 — Loading Guidelines, UIC, Paris (2015).
- [IV.9] INTERNATIONAL MARITIME ORGANIZATION, Code for the Safe Carriage of Packaged Irradiated Nuclear Fuel, Plutonium and High-Level Radioactive Wastes on Board Ships (INF Code), Resolution MSC.178(79), IMO, London (2009).

- [IV.10] INTERNATIONAL ORGANIZATION FOR STANDARDIZATION, Series 1 Freight Containers — Specification and Testing — Part 3: Tank Containers for Liquids, Gases, and Pressurized Dry Bulk, ISO 1496-3:1995, ISO, Geneva (1995) and subsequent Amendment 1:2006.
- [IV.11] VEREIN DEUTSCHER INGENIEURE, VDI 2700 Part 2, Securing of loads on road vehicles – Calculation of tie-down forces – Fundamentals, Beuth Verlag, Berlin (2014).
- [IV.12] UNITED STATES OFFICE OF THE FEDERAL REGISTER, Title 49, US Code of Federal Regulations, Part 393.100-102, US Government Printing Office, Washington, DC (1990).
- [IV.13] DETR Radioactive Materials Transport Division, Guide to an Application for Competent Authority Approval for Radioactive Material in Transport, Rep. DETR/RMTD/0003 (2001).
- [IV.14] UN Recommendations on the Transport of Dangerous Goods - Model Regulations Eighteenth revised edition (2013).
- [IV.15] SHAPPERT, L.B., RATLEDGE, J.E., MOORE, R.S., DORSEY, E.A., “Computed calculation of wire rope tiedown designs for radioactive material packages”, Packaging and Transportation of Radioactive Materials, PATRAM 95 (Proc. Int. Symp. Las Vegas, 1995), United States Department of Energy, Washington, DC (1995).
- [IV.16] GWINN, K.W., GLASS, R.E., EDWARDS, K.R., Over-the-Road Tests of Nuclear Materials Package Response to Normal Environments, Rep. SAND 91-0079, Sandia Natl Labs, Albuquerque, NM (1991).
- [IV.17] TRANSPORT CONTAINER STANDARDISATION COMMITTEE, Tie-down Systems Proofs of Design Calculations, Rep. TCSP(93)P1072 (1994).
- [IV.18] CORY, A.R., Flask Tie-down Design and Experience of Monitoring Forces, RAMTRANS Vol. 2 No. 1–3 pp. 15–22 (1991).
- [IV.19] PUJET, D., MALESYS, P., Measurement of the Acceleration Undergone by the Trunnions of Irradiated Fuel Transport Flasks During Normal Use, Proceedings of PATRAM 1989, Washington, USA(1989).
- [IV.20] RAIL SAFETY and STANDARDS BOARD, Guidance on the Structural Design of Rail Wagons including Rail Tank Wagons, GM/GN2688 Issue 1, RSSB, London (2010).
- [IV.21] DEPARTMENT OF TRANSPORT, Safety of Loads on Vehicles, HMSO, London (2002).
- [IV.22] DIXON, P., Package Tie-downs — A Programme of Measurement and Assessment, RAMTRANS Vol 8 Nos 3-4, pp. 339-344 (1997), Nuclear Technology Publishing.
- [IV.23] GILLES, P., et al., Stowing of Packages Containing Radioactive Materials During their Road Transportation with Trucks for Loads up to 38 Tonnes, Rep. TNB 8601-02, Transnubel SA, Brussels (1985).

- [IV.24] DRAULANS, J., et al., Stowing of Packages Containing Radioactive Materials on Conveyances, Rep. N/Ref:23.906/85D-JoD/IP, Transnubel SA, Brussels (1985).
- [IV.25] KERNTECHNISCHER AUSSCHUSS, Load Attaching Points on Loads in Nuclear Power Plants, KTA Safety Standard KTA 3905 (2012-11), KTA Geschäftsstelle, Bundesamt für Strahlenschutz, Salzgitter, Germany (2012).
- [IV.26] INTERNATIONAL ORGANIZATION FOR STANDARDIZATION, Series 1 Freight Containers — Specification and Testing — Part 1: General Cargo Containers for General Purposes, ISO 1496-1:1990(E), ISO, Geneva (2013) and subsequent Amendments 1:1993, 2:1998, 3:2005, 4:2006 and 5:2006.
- [IV.27] INTERNATIONAL MARITIME ORGANIZATION, IMO/ILO/UNECE Guidelines for Packing of Cargo Transport Units (CTUs), IMDG Code Supplement (Amdt. 33-06), IMO, London (2006).
- [IV.28] INTERNATIONAL ORGANIZATION FOR STANDARDIZATION, Nuclear Energy — Fuel Technology — Trunnions for Packages Used to Transport Radioactive Material, ISO 10276:2010, ISO, Geneva (2010).
- [IV.29] DIN EN 12195-1, Load restraining on road vehicles-Safety-Part 1: Calculation of securing forces, (2011).
- [IV.30] BAM-GGR 012 Guideline on Design Assessment of Lid Systems and Load Attachment Systems of Transport Packages for Radioactive Materials. Bundesanstalt für Materialforschung und -prüfung (BAM), Edition 2012-11.
- [IV.31] EUROPEAN COMMITTEE FOR STANDARDIZATION Railway applications-Structural requirements of railway vehicle bodies-Part 2: Freight wagons, EN 12663-2:2010-07, CEN, Brussels (2010)
- [IV.32] UNITED NATIONS ECONOMIC COMMISSION FOR EUROPE, INLAND TRANSPORT COMMITTEE, European Agreement Concerning the International Carriage of Dangerous Goods by Road (ADR), 2019 Edition, UNECE, New York and Geneva (2018).
- [IV.33] INTERGOVERNMENTAL ORGANIZATION FOR INTERNATIONAL CARRIAGE BY RAIL (OTIF), Regulations Concerning the International Carriage of Dangerous Goods by Rail (RID), 2017 Edition, OTIF, Bern (2016).
- [IV.34] STERTHAUS, J.; BALLHEIMER, V.; WILLE, F.: Analysis Methodology and Assessment Criteria for Bolted Trunnion Systems of Type B Packages for Radioactive Materials. Proceedings of PATRAM 2010, London, UK (2010).
- IV.35] STERTHAUS, J.; BALLHEIMER, V.; KUSCHKE C.; WILLE, F.: Numerical Analysis of Bolted Trunnion Systems of Packages for Radioactive Materials. Proceedings of the ASME 2012 Pressure Vessels & Piping Division Conference (PVP2012), Toronto, Canada (2012).
- [IV.36] AMERICAN SOCIETY OF MECHANICAL ENGINEERS, Boiler and Pressure Vessel Code, ASME, New York , (2015).

Appendix V

GUIDELINES FOR THE SAFE DESIGN OF PACKAGES AGAINST BRITTLE FRACTURE

INTRODUCTION

V.1. This appendix is based on material that was published originally as Chapter 2 of IAEA-TECDOC-717 [V.1] and revised in a series of subsequent consultants' meetings. This publication contains further information on the assessment of fracture resistance based on design evaluation using fracture mechanics.

V.2. Packages for the transport of radioactive material have to meet the requirements of the Transport Regulations. The packages have to meet stringent criteria to limit dose rate, to ensure containment of the radioactive material and to prevent nuclear criticality. Compliance is required to be maintained under severe accident conditions. Thus, in the design of such packages, consideration has to be given to the prevention of all modes of failure of the package that could result in non-compliance with these requirements. The requirements of para. 701(d) of the Transport Regulations are always applicable (i.e. the calculation procedures and parameters are required to be reliable or conservative).

V.3. This appendix provides guidance for the evaluation of designs to prevent brittle fracture of structural components in radioactive material packages. Three methods are discussed:

- Method 1: Evaluation and use of materials that remain ductile and tough throughout the required service temperature range, including down to -40°C .
- Method 2: Evaluation of ferritic steels using nil-ductility transition temperature (NDTT) measurements correlated to fracture resistance.
- Method 3: Assessment of fracture resistance based on a design evaluation using fracture mechanics.

V.4. Method 1 is included to cover the approach that seeks to ensure that, whatever the loading conditions required to cause failure, such a failure will always involve extensive plasticity and/or ductile tearing, and unstable brittle fracture will not occur under any circumstances. Method 2 is addressed to provide consistency with generally accepted practice for evaluating ferritic steels. Method 3 provides an approach for evaluating brittle fracture that is suitable for a wide range of materials. This guidance does not preclude alternative methods that are properly justified by the package designer and accepted by the competent authority.

GENERAL CONSIDERATION OF EVALUATION METHODS

V.5. Many materials are known to be less ductile at low temperatures or high loading rates than at moderate temperatures and under static loading conditions. For example, the ability of ferritic steels with crack-like flaws to absorb energy when stressed in tension changes markedly over a narrow temperature range. Fracture toughness of ferritic steel changes markedly over the transition temperature range. Toughness increases rapidly over a relatively narrow range of temperature from a 'lower shelf' or brittle plane strain region with cleavage fracture, through an elastic plastic region, to an 'upper shelf' or region with ductile tearing fracture and plasticity, in which the fracture toughness is generally high enough to preclude brittle fracture. The temperature at which the toughness starts to rise rapidly with increasing temperature corresponds to the NDTT. This type of transition temperature behaviour only occurs in the presence of crack-like flaws that produce a triaxial stress state, and when the materials show an increase in yield strength with decreasing temperature. The same materials often show an increase of yield strength with increasing loading rate and hence the transition temperature may also be dependent on loading rate. In all these cases, when the material is effectively in a brittle

state, tensile loading of such materials can lead to unstable crack propagation with subsequent brittle fracture, even when the nominal stresses are less than the material yield strength. Small crack-like defects in the material may be sufficient to initiate this unstable growth.

V.6. Criteria for the prevention of fracture initiation and potentially unstable fracture propagation in ferritic steel components, such as pressure vessels and piping used in the power, petroleum and chemical process industries, are well developed and have been codified into a number of national and international standards. These criteria can be classified into two general types:

- (i) Criteria based solely on material testing requirements. These are usually intended to demonstrate that some material property (e.g. impact energy) has been shown by previous experience or by full scale prototype tests to give satisfactory performance, or may be correlated to fracture toughness to provide an adequate margin against brittle fracture.
- (ii) Criteria based on a combination of material testing, calculation of applied stresses and workmanship and inspection standards. These are intended to demonstrate that a sufficient margin exists between the calculated design state and the measured material response state.

V.7. Methods 1 and 2 in para. V.3 are based on the criteria in para. V.6 (i), whilst Method 3 follows the basic fracture mechanics approach or the extensions to elastic plastic fracture mechanics described later. While linear elastic fracture mechanics can be used if small scale yielding limits prevail, if more extensive yielding occurs then elastic plastic fracture mechanics methods should be used. Other evaluation methods are possible. Any approach suggested by the package designer is subject to the approval of the competent authority.

Method 1

V.8. Brittle fracture can occur suddenly, without warning, and have disastrous consequences for the packaging. Consequently, the Method 1 approach requires that packaging be constructed of materials that are not subject to brittle failure before ductile failure when subjected to the normal and accident conditions specified in the Transport Regulations.

V.9. An example of Method 1 is the use of austenitic stainless steels for flask material. These materials do not have fracture toughness behaviour that is sensitive to temperature over the range of interest in package designs and generally have good ductility and toughness performance. It is not always the case that cast austenitic steels have good properties, however, and some form of mechanical testing to confirm ductile behaviour and high fracture toughness may be required.

V.10. Method 1 also has the benefit of not having to rely on limiting stress level, flaw size and fracture toughness for brittle fracture resistance, although normal design procedures have to be applied for ductile or other modes of failure.

Method 2

V.11. The basis for determining the NDTT is the highest temperature at which brittle fracture does not run in the parent material from a brittle weld bead in the standard drop weight test [V.2]. This can be thought of as the bottom of the transition temperature curve, either for propagation or crack arrest or for dynamic initiation from small initial cracks.

V.12. Examples of the use of the NDTT approach of Method 2 include Refs [V.3–V.6]. These methods address, for example, ferritic steels, for which there are substantial databases relating impact energy (Charpy testing) to fracture toughness. In such cases, the Charpy impact energy can be used as an indirect indicator of material toughness. This approach may be used for a variety of high quality carbon

and carbon–manganese ferritic steels. The basic acceptance criterion in Refs [V.3–V.5] is the requirement of a minimum impact energy (or lateral expansion) from a Charpy V-notch test at a prescribed temperature, although the underlying justification is based on NDTT approaches.

V.13. Further examples of Method 2 are in Refs [V.7, V.8]. These prescribe levels of NDTT that need to be achieved for ferritic steels, based on section thickness and temperature. They require a minimum temperature difference between the NDTT of the material and the lowest temperature to be considered for accident conditions (taken as -29°C), as a function of section thickness. This temperature difference is based on correlations between NDTT and fracture toughness. While these regulatory guides specifically address ferritic steels, the same approach could be considered for other materials showing transition temperature behaviour and for which a correlation between NDTT and fracture resistance can be demonstrated. The standardized test procedure in Ref. [V.9] is only applicable for ferritic steels. There are no standardized test methods for measuring the NDTT of other materials. There is, however, the possibility of using the dynamic tear test to obtain the NDTT, or at least an indication of tearing resistance for other materials [V.10]. This will give more severe (conservative) values than those derived from Charpy tests.

V.14. In Refs [V.7, V.8] consideration is given to different safety margins for different types of package and contents and the crack arrest behaviour of materials is also taken into account. This is achieved by specifying a maximum allowable NDTT based on technical reports in Refs [V.11, V.12] and the following equation:

$$\beta = \frac{1}{B} \left(\frac{K_{ID}}{\sigma_{yd}} \right)^2 \quad (\text{V.1})$$

where

σ_{yd} is the dynamic yield stress;

K_{ID} is the critical dynamic fracture toughness;

B is the section thickness.

V.15. For packages containing spent fuel, high level waste or plutonium, the United States Nuclear Regulatory Commission looks for sufficient fracture toughness to prevent the extension of a through thickness crack at dynamic yield stress level. This is similar to a crack arrest philosophy, and – regarding Eq. (V.1) in para. V.14 – necessitates a value of β of not less than 1.0. This is equivalent to the nominal plastic zone being of such a size that plane strain conditions would not be expected to be maintained and therefore that the fracture toughness should be towards the upper shelf region and the material be ductile. For other Type B(U) or Type B(M) packages, the value of β should be not less than 0.6. This is equivalent to the fracture toughness being off the bottom shelf and in the transition region with elastic plastic failure expected to dominate. For packages that contain only LSA material or less than 30A₁ or 30A₂, the United States Nuclear Regulatory Commission is prepared to consider the use of linear elastic fracture mechanics approaches to prevent fracture initiation. This can be achieved by requiring β to be not less than 0.4. For these cases, for thicknesses of less than 0.1 m, the use of fine grained normalized steels without further analysis or testing may be considered. For all these approaches the required fracture toughness can be specified by the use of the maximum NDTT. These approaches also have the benefit of not having to rely on limiting stress levels and flaw sizes. However, normal design procedures have still to be applied for ductile or other modes of failure.

Method 3

V.16. For the transport of radioactive material, Methods 1 and 2 do not take advantage of the ability to limit stresses through the provision of impact limiting devices and non-destructive examination (NDE) sufficient to detect and size prescribed flaws. Furthermore, the correlation of impact energy to fracture toughness may not be applicable to a broad range of materials, thereby restricting the use of alternative containment boundary materials.

V.17. Numerous examples of Method 3 that are valid for nuclear power plant components can be identified. Such examples, although not directly applicable to the evaluation of transport package design, may be instructive in terms of their use of fracture mechanics principles. These examples include Refs [V.13–V.18]. These examples allow some latitude in the design in terms of material selection, together with the ability to determine stresses and NDE requirements such that fracture initiation and brittle fracture are precluded. The fundamental approach for linear elastic fracture mechanics is applied in all of these examples, although differences arise in the application of safety factors. These examples are mainly concerned with slowly applied loads, which may fluctuate. For application of these principles for loads encountered in drop or penetration tests, account should be taken both of the magnitude of the resulting stresses and of the material response to the rate of loading.

CONSIDERATIONS FOR FRACTURE MECHANICS

V.18. The mechanical property that characterizes a material's resistance to crack initiation from pre-existing crack-like defects is its initiation fracture toughness. The curve with the results of the measurements of this property, as a function of temperature and loading rate, illustrates the transition from brittle to ductile behaviour for those materials that show transition temperature behaviour. Depending on the localized state of stress around the defect and the extent of plasticity, the fracture toughness is measured in terms of the critical level of the stress intensity factor (K_I), if the stress–strain conditions are linear–elastic; or, if the stress–strain conditions are elastic–plastic, the toughness may be represented by the critical level of the energy line contour integral, J_I , or by the critical level of the crack tip opening displacement (CTOD), δ . In accordance with fundamental fracture mechanics theory, the level of the applied crack tip driving force (represented by stress intensity factor K_I , contour integral J_I or CTOD δ_I) has to be less than the critical value for the material's fracture toughness (in the same form, $K_{I(mat)}$, $J_{I(mat)}$ or $\delta_{I(mat)}$) to preclude fracture initiation and subsequent brittle fracture. Standard testing methods for critical values of K_I are given in Refs [V.19–V.24]. A single set of recommendations to cover the various fracture toughness parameters is given in Ref. [V.25]. The value of $K_{I(mat)}$, $J_{I(mat)}$ or $\delta_{I(mat)}$ necessary to avoid fracture initiation depends on loading and environmental combinations of interest. For plane strain conditions, appropriate for the high thicknesses often necessary for many Type B(U) or Type B(M) packages, the critical fracture toughness for static loading shows a minimum value that is termed K_{Ic} , J_{Ic} or δ_{Ic} . The fracture toughness under increased loading rate or impact conditions, which is termed K_{Id} for dynamic loading, may be significantly lower for some materials than the corresponding static value at the same temperature, K_{Ic} . If the initial depth of the defect, in combination with the applied loading, results in an applied stress intensity factor that equals the material toughness, crack initiation will occur and the depth of the defect is referred to as the critical depth. Under these conditions, continued propagation may occur, leading to instability and failure.

V.19. For some materials, results of fracture toughness tests that are valid in accordance with Ref. [V.19] cannot be obtained in the standard tests because of excessive plasticity. Furthermore, some materials may not show unstable fracture propagation when initiation occurs, but further crack extension requires an increase in the crack driving force (i.e. in the early stages an increase in load is required to cause further crack growth). Both processes (i.e. plasticity and stable ductile tearing) absorb energy and are clearly desirable attributes for materials that need to meet the demanding design requirements for transport flasks. It should be noted that the geometric and metallurgical effects of

large section thicknesses often used in package designs make it difficult to be certain of the ductile tearing response in service as compared with standard test geometries.

V.20. The recommended approach for fracture mechanics evaluation of transport package designs is based on ‘prevention of fracture initiation’ and hence of unstable crack propagation (growth) in the presence of crack-like defects. The principles of linear–elastic fracture mechanics may sometimes be sufficient. Under some conditions, and as justified by the package designer and accepted by the competent authority, the principles of elastic–plastic fracture mechanics may be appropriate. In such cases, the prevention of crack initiation remains the governing criterion and no reliance in design should be placed on any predicted ductile tearing resistance. Guidance is provided in paras V.21–V.46 for design against fracture initiation in packages subjected to the mechanical tests prescribed in paras 722, 725 and 727 of the Transport Regulations.

V.21. The implication of adopting an approach based on fracture mechanics is that quantitative analysis should be carried out. The analysis should cover the interaction between postulated flaws in the package, stress levels that may occur, and the properties of the materials, particularly fracture toughness and yield strength. Thus, consideration should be given to the possible presence of flaws at the manufacturing stage, and the design method has to postulate maximum flaw sizes that could credibly occur and remain after any inspection and repair programme. This, in turn, means that the types of inspection method and their capability to detect and size such flaws at critical geometric locations also have to be considered. In this appendix, this is the basis of the reference flaw concept. It is likely that a combination of NDE will be necessary. The appropriate combination to be specified by the designer should include locations to be inspected by each method and the acceptance levels for any flaws found. The inspectability of the geometry in relation to the size and location of flaws that might be missed is an important element of any design approach making use of fracture mechanics principles. These aspects are discussed further in this appendix. Furthermore, it should be possible to determine the stress levels that would occur in different parts of the package under the various accident conditions and to have some estimate of the uncertainties in such determinations. Finally, there needs to be knowledge of the fracture toughness of the material used for the package over the full temperature range of operating conditions, based on either test results, lower bound estimates or reference curves, and including the effects of increased rates of loading that will occur under impact accidents.

V.22. The fundamental linear–elastic fracture mechanics equation that describes structural behaviour in terms of the crack tip driving force as a function of applied stress and flaw depth is as follows:

$$K_I = Y\sigma\sqrt{\pi a} \quad (\text{V.2})$$

where

K_I is the applied stress intensity factor (MPa $\sqrt{\text{m}}$);

Y is the constant based on size, orientation and geometry of flaw and structure;

σ is the applied nominal stress (MPa);

a is the flaw depth (m).

V.23. Further, to preclude brittle fracture, the applied stress intensity factor should satisfy the relationship:

$$K_I < K_{I(\text{mat})} \quad (\text{V.3})$$

where $K_{I(\text{mat})}$ defines the fracture toughness.

V.24. This should be obtained from tests at the appropriate rate of loading relevant to that which will be experienced by the package, with account taken of the effects of any stress limiters included in the design.

V.25. For

$$K_I = K_{I(mat)} \quad (V.4)$$

equation (V.2) can be combined with Eq. (V.4) to give an expression for the critical flaw depth a_{cr} as follows:

$$a_{cr} = \frac{1}{\pi} \left(\frac{K_{I(mat)}}{Y \sigma} \right)^2 \quad (V.5)$$

V.26. The purpose of the brittle fracture evaluation process is to ensure that the three parameters of this characterization (material fracture toughness, applied stress and flaw size) satisfy Eqs (V.2) and (V.3), or corresponding elastic–plastic treatments, thereby precluding fracture initiation.

V.27. The effect of plasticity and local yielding at the tip of a crack is to increase the crack tip severity above that for the same crack size and stress level under linear–elastic stressing conditions alone. In elastic–plastic fracture mechanics, there are a number of ways of taking into account the interaction between plasticity and crack tip severity. For example, two of these approaches have been codified into various national documents — the applied J-integral [V.26] and the failure assessment diagram (FAD) [V.17, V.27] — and can be justified for use in packaging evaluations. Acceptance criteria for these elastic–plastic methods are typically more complex than the simple limit provided by Eq. (V.3). For the case of the applied J-integral method, acceptance criteria should include a limit on the applied J-integral itself at the prescribed definition of initiation. For the FAD method, the assessment coordinates L_r and K_r for plastic collapse and brittle fracture can be calculated for stresses and postulated flaw depths, with an acceptance criterion that such assessment points lie inside the FAD surface (see Fig. V.1). It is important to recognize that when significant yielding occurs, the use of linear–elastic fracture mechanics may be non-conservative if the stress intensity factor is estimated only from the stress level and crack size without taking account of yielding. For further details, Refs [V.18, V.26, V.27] should be consulted.

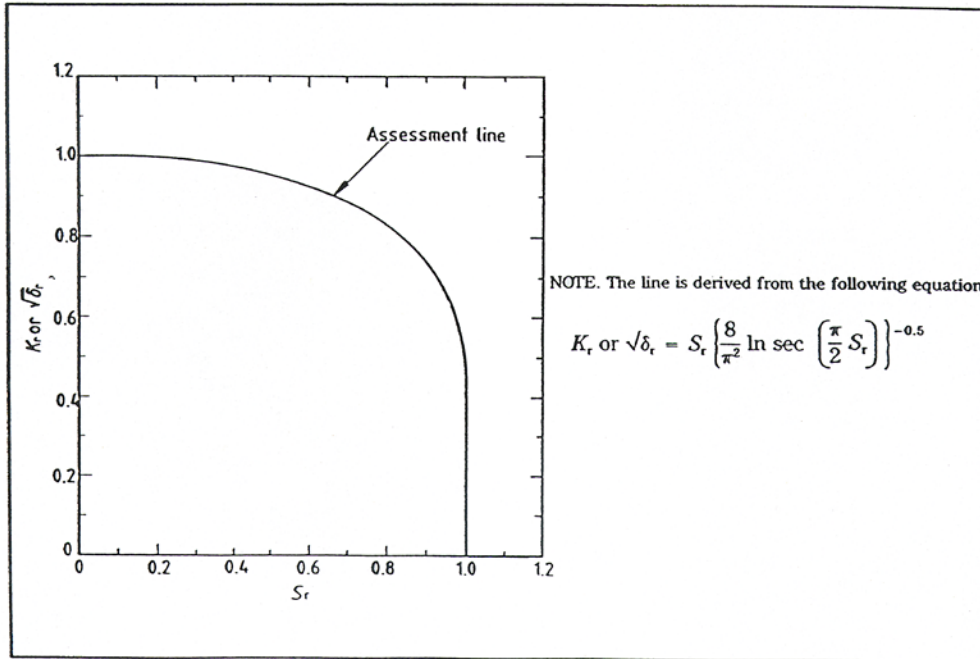

(a)

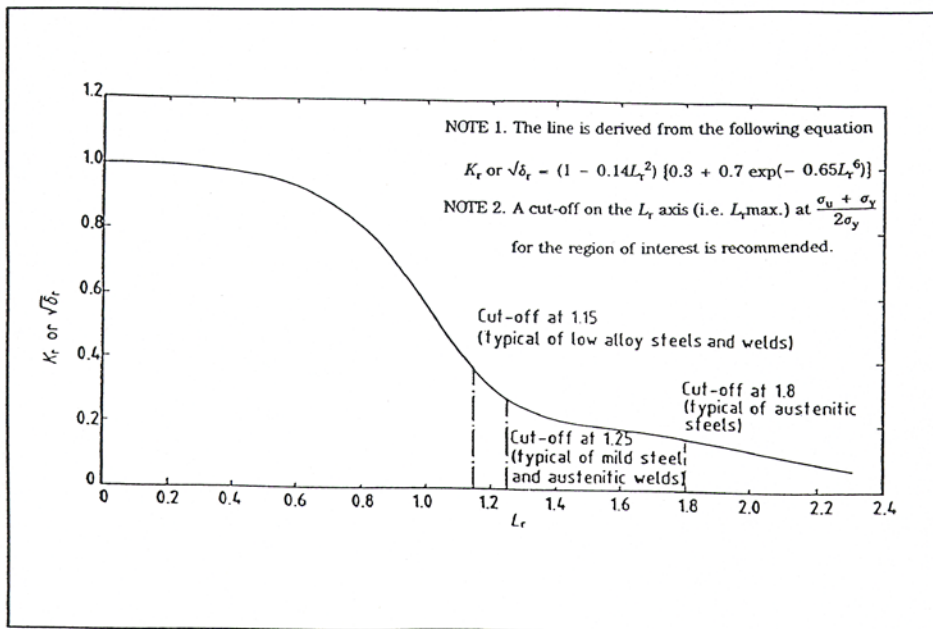

(b)

FIG. V.1. Failure assessment diagrams for elastic plastic fracture mechanics treatments [V.17]. (a) Level 2 assessment diagram; (b) level 3 assessment diagram.

V.28. The yielding of components outside the containment boundary, which are specifically designed to absorb energy by plastic flow, should not be regarded as unacceptable.

SAFETY FACTORS FOR METHOD 3

V.29. Any safety factors that might be applied to Eq. (V.3), or to the parameters that make up Eq. (V.3) and its elastic–plastic extensions, should take into account any uncertainties in the calculation or measurement of these parameters. These uncertainties might include those associated with the calculation of the state of stress in the package, the examination of the package for defects and the measurement of material fracture toughness. Thus, the overall safety factor depends on whether the values used for the different input parameters are best estimate (mean) values or upper bounds for loading parameters and postulated defect sizes and lower bounds for fracture toughness. In particular, concerns about uncertainties in NDE can be accommodated by appropriate conservatism in the selection of the reference flaw.

V.30. For the purposes of prevention of fracture initiation in package materials, the safety factors for normal conditions of transport and accident conditions should be in general agreement with safety factors that have been developed for similar loading conditions in the referenced applications of the linear–elastic fracture mechanics approach. For example, for loading conditions that are expected to occur as part of normal operation during service life, Ref. [28] for in-service inspection of nuclear power plant components provides for an overall minimum safety factor of $\sqrt{10}$ (approximately 3) on fracture toughness to be applied to Eq. (V.3). For unexpected (but design basis) loading conditions, such as the accident conditions, Ref. [28] provides for an overall minimum safety factor of $\sqrt{2}$ (approximately 1.4) on fracture toughness to be applied to Eq. (V.3). Such minimum safety factors to Eq. (V.3) should use upper bounds for loading parameters and postulated defect sizes and lower bounds for fracture toughness, by using statistical assessments, if appropriate. The factors of safety should be selected and justified by the package designer, with acceptance by the competent authority, taking into account confidence in the validation of methods used for stress analysis (e.g. finite element analysis codes), scatter in material properties and uncertainties in flaw detection and sizing by NDE.

EVALUATION PROCEDURE FOR METHOD 3

V.31. The general steps to be followed should be as follows:

- (a) Postulation of a reference or design basis flaw at the most critical location in the packaging and in the most critical orientation;
- (b) Calculation of the stresses due to the mechanical tests described in paras 722, 725 and 727 of the Transport Regulations, and ensuring that any required load combinations are considered;
- (c) Calculation of the applied stress intensity factor at the tip of the design basis flaw;
- (d) Determination or lower bound estimate of the fracture toughness of the material for the loading rates to which the package may be subjected;
- (e) Calculation of the ratio of applied net section stress to yield stress under the relevant loading conditions;
- (f) Satisfaction of any margin of safety between the applied net stress intensity factor and the accepted material fracture toughness value and between the applied stress and yield stress.

This will ensure that the flaw will not initiate or grow as a result of mechanical tests specified by the Transport Regulations and therefore will not lead to unstable crack propagation and/or brittle fracture.

The net stress is the evaluated stress that takes into account the reduced section due to the presence of the crack.

V.32. A variation on the sequence in para. V.31 is for the mechanical tests to be used to directly demonstrate the resistance to brittle fracture. In this case, the test measurements may be used: (i) to provide inference of the stress field for calculations of applied stress intensity factors; and/or (ii) to provide direct confirmation of the recommended margin against fracture initiation. For the second of these, a crack is placed at a location in the prototype test packaging that is most vulnerable to flaw initiation and growth from the mechanical test loads at a minimum temperature of -40°C . The reference flaw shape should be semi-elliptical, with an aspect ratio (length to depth) of 6:1 or greater. The tip of this artificial flaw should be as crack-like as possible, with a reference flaw acuity that is justified by the package designer and accepted by the competent authority. An acuity of the radius at the extreme tip of the crack of not greater than 0.1 mm has been suggested for ductile iron [V.29]. The depth of this flaw is determined by using stresses as previously calculated or inferred from strain measurements, and an appropriate factor of safety should also be considered when computing the artificial flaw depth.

V.33. Recommendations for each of these procedural steps are provided in paras V.34–V.46.

Flaw considerations

V.34. Three different flaw sizes are referred to in this appendix. The ‘reference flaw size’ is a postulated flaw size used for analysis purposes. The ‘rejection flaw size’ is a flaw size that, if discovered during pre-service inspection, would fail to meet quality control requirements. The ‘critical flaw size’ is that size that would potentially be unstable under design basis loading conditions.

V.35. With respect to either demonstration by analysis or demonstration by test, the reference flaw should be placed at the surface of the packaging containment wall at the location of the highest applied stress. The possibility of fatigue cracks developing in service should be considered where the package is subjected to cyclic or fluctuating loads. Where the location of the highest applied stress is uncertain, multiple demonstrations may be necessary. The orientation of the reference flaw should be such that the highest component of surface stress, as determined from calculation or experimental measurement, is normal to the plane of the flaw. This consideration should take account of the presence of any stress concentration regions. The depth of the reference flaw should be such that its relationship to volumetric examination sensitivity, detection uncertainty, rejection flaw size and critical flaw size is justified. The reference flaw depth should be such that, in association with the demonstrated volumetric and surface examination sensitivities, the non-detection probability is ensured as being sufficiently small, as justified by the package designer. A limiting small depth may be chosen at the size where the probability of non-detection can be demonstrated as being statistically insignificant, with due allowance for uncertainties in the testing method.

V.36. The reference flaw of 6:1 aspect ratio should have an area, normal to the direction of maximum stress, greater than typical pre-service inspection indications that might be the cause of rejection or repair of a fabricated packaging containment wall. However, since the reference flaw is a crack-like surface defect, rather than a more typical real defect (e.g. subsurface porosity cloud or slag inclusion), the selection of this flaw size is extremely conservative relative to workmanship standards.

Management system and non-destructive examination (NDE) considerations

V.37. For the satisfactory performance of any transport package, it should be designed and manufactured to satisfactory standards, with suitable materials, and free of gross flaws, irrespective of whether a design approach based on fracture mechanics has been used or not. The implication is that the design and manufacturing stages should be subject to management system principles, and the materials should be subject to quality control to ensure that they are within specification requirements.

For metallic packages, samples should be taken to check that chemical analysis, heat treatment and microstructure are satisfactory and that no inherent flaws are present. Metallic packages should be subject to NDE with a combination of surface crack detection and volumetric testing. Surface crack detection should be done by appropriate means, such as magnetic crack detection, dye penetrant or eddy current testing in accordance with standard procedures.

V.38. Volumetric testing should normally be by radiographic or ultrasonic methods, again in accordance with standard procedures. The design of the package should be suitable for such non-destructive testing. Where an approach based on fracture mechanics is used with a reference flaw concept, the designer of the package should demonstrate that the specified NDE methods are able to detect any such flaw and that these NDE methods are carried out in practice.

V.39. Consideration should be given by the designer to the possibility of flaws developing or growing and to possible material degradation in service. Requirements for repeat or periodic NDE should be specified by the designer and approved by the competent authority.

Fracture toughness considerations

V.40. The calculated applied stress intensity factor should be shown to be less than the material fracture toughness value in Eq. (V.3), with appropriate allowance for plasticity effects and factors of safety. The method for determining the material fracture toughness should be selected from three options, all of which are illustrated in Fig. V.2. Each of these options includes the generalization of a statistically significant database of material fracture toughness values obtained on product forms that are representative of material suppliers and package applications. The first two options should include material fracture toughness values that are representative of the strain rate, temperature and constraint conditions (e.g. thickness) of the actual package application. These same considerations apply to material fracture toughness measurements used to support an elastic-plastic fracture evaluation.

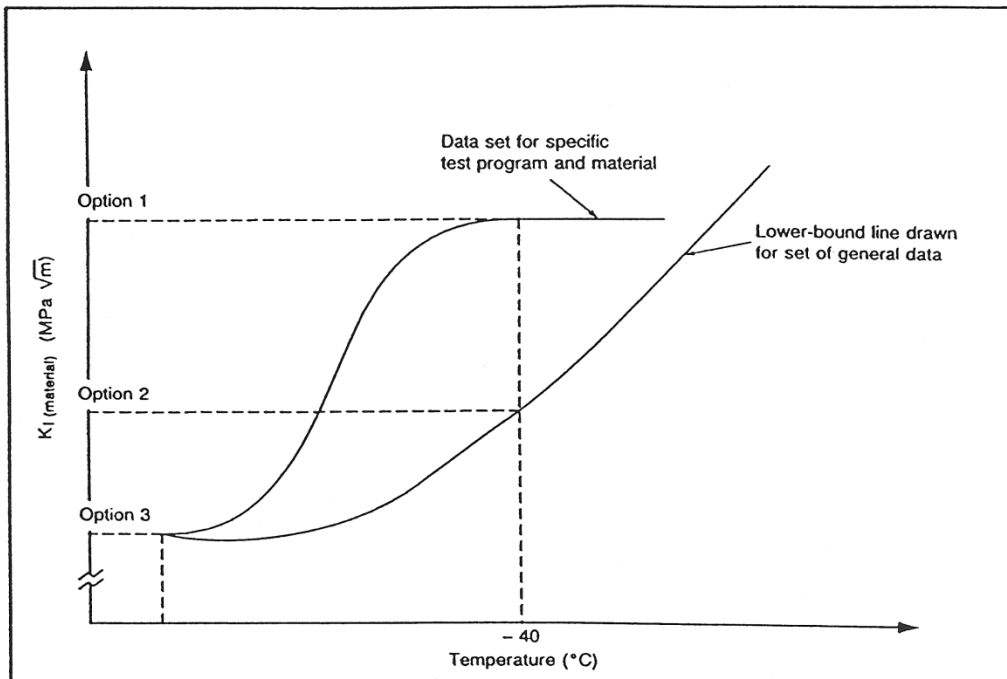

FIG. V.2. Relative values of $K_{I(material)}$ measurements based on the selection of options 1, 2 or 3.

V.41. Option 1 should be based on the determination of a minimum value of fracture toughness at a temperature of -40°C for a specific material. The minimum value is shown in Fig. V.2 as representing a statistically significant data set for a limited number of samples from a limited number of material suppliers, obtained at appropriate loading rate and geometric constraint conditions. The samples should be representative of product forms appropriate for the particular package application.

V.42. Option 2 should be based on the determination of a lower bound or near lower bound value of the material fracture toughness, $K_{I(mat)} = K_{Ib}$, as shown in Fig. V.2. This option would encompass, as a limiting case, the reference material fracture toughness determination for ferritic steels that is prescribed, for example, in Ref. [V.4]. The lower bound or near lower bound value can be based on a composite of data for static, dynamic and crack arrest fracture toughness. An advantage of this option is the potential for reducing the testing programme for materials that can be referenced to the lower bound or near lower bound curve. A relatively small, but suitable, number of data points may be sufficient to demonstrate the applicability of the curve to specific heats, grades or types of material.

V.43. Option 3 should be based either on the minimum value of a statistically significant fracture toughness data set satisfying the static loading rate and crack tip constraint requirements of Ref. [V.19], or on elastic-plastic methods of measuring fracture toughness [V.3, V.4]. The test temperature for linear elastic fracture mechanics tests in accordance with Ref. [V.19] should be at least as low as -40°C , but may have to be even lower to satisfy the Ref. [V.19] conditions, as shown in Fig. V.2. Fracture toughness tests using elastic-plastic methods should be carried out at the minimum design temperature. The conservatism of this option, particularly if tests are carried out at temperatures lower than -40°C , may be such that, if justified by the package designer and accepted by the competent authority, a reduced factor of safety could be used.

Stress consideration

V.44. With respect to either demonstration by test or demonstration by analysis, the calculation of the applied stress intensity factor at the tip of the reference flaw should be based on maximum tensile stresses in the fracture critical components that are justified by the package designer and accepted by the competent authority. The fracture critical components are defined as those components whose failure by fracture could lead to penetration or rupture of the containment system. The stresses may be determined by calculations for an unflawed package. Methods commonly used include direct stress calculations by specialist finite element codes for dynamic analysis, or indirect stress calculation from test results. With finite element analysis, the approach to impact loading may either be to attempt to model inertia effects or may be quasi-static, provided that the response of impact limiters and the packaging body can be decoupled. The use of finite element computer codes should be limited to those capable of performing impact analysis and to designers who have demonstrated their qualification to the satisfaction of the competent authority. The computer model should be adjusted to give accurate results in the critical areas for each impact point and attitude examined. When the stress field is inferred from surface strain measurements on either a scale model or full scale package performance test, the inferred stress field should also be justified. Account should be taken of possible errors in measured strains due either to placement errors or to gauge length effects when strain gauges are used on local stress concentration regions. The applied stress intensity factor may be calculated directly from stress analysis or calculated conservatively from handbook formulas that take into account flaw shape and other geometric and material factors.

V.45. Since the calculated stress fields may be dependent on impact limiter performance, mass distributions and structural characteristics of the package itself, the justification of the stresses will, in turn, depend on the justification of the analytical models. Where reliance is placed on impact limiters to ensure that design stress levels used in conjunction with reference flaws and assumed minimum fracture toughness are not exceeded, validation of the analysis should be provided by the designer to the competent authority, including justification of safety factors to allow for uncertainties. Experience of using dynamic finite element analysis has shown that sufficiently reliable or conservative estimates of peak stress can be obtained provided that (i) the computer code is capable of analysing impact events, (ii) reliable or conservative property data are used, (iii) the model is either accurate or has conservative simplifications and (iv) the analysis is carried out by qualified personnel. The justification of stress fields inferred from performance tests will depend on the justification of test instrumentation characteristics, locations and data interpretation. Evaluation of either calculated or inferred stress fields may also require an understanding of relevant dynamic material and structural characteristics.

V.46. Additional guidance in the application of Option 3 can be found in Refs [V.30–V.32].

REFERENCES TO APPENDIX V

- [V.1] INTERNATIONAL ATOMIC ENERGY AGENCY, Guidelines for Safe Design of Shipping Packages Against Brittle Fracture, IAEA-TECDOC-717, IAEA, Vienna (1993).
- [V.2] AMERICAN SOCIETY FOR TESTING AND MATERIALS, Annual Book of ASTM Standards: Standard Test Method for Drop Weight Test to Determine Nil Ductility Transition Temperature of Ferritic Steels, Vol. 03.01, ASTM E208-87a, ASTM, Philadelphia, PA (1987).

- [V.3] BRITISH STANDARDS INSTITUTION, Specification for Unfired Fusion Welded Pressure Vessels, BS 5500, BSI, London (1991).
- [V.4] AMERICAN SOCIETY OF MECHANICAL ENGINEERS, Boiler and Pressure Vessel Code, Section III, Division 1, Rules for the Construction of Nuclear Power Plant Components, ASME, New York (1992).
- [V.5] AMERICAN SOCIETY OF MECHANICAL ENGINEERS, Boiler and Pressure Vessel Code, Section VIII, Division 1, Rules for the Construction of Pressure Vessels, ASME, New York (1992).
- [V.6] ASSOCIATION FRANÇAISE POUR LES RÈGLES DE CONCEPTION ET DE CONSTRUCTION DES CHAUDIÈRES ÉLECTRONUCLÉAIRES (AFCEN), French Nuclear Construction Code, RCCM: Design and Construction Rules For Mechanical Components of PWR Nuclear Facilities, Subsection Z, Appendix ZG, Fast Fracture Resistance, Framatome, Paris (1985).
- [V.7] NUCLEAR REGULATORY COMMISSION, Fracture Toughness Criteria for Ferritic Steel Shipping Cask Containment Vessels with a Wall Thickness Greater than 4 Inches (0.1 m) But Not Exceeding 12 Inches (0.3 m), Regulatory Guide 7.12, NRC, Washington, DC (1991).
- [V.8] NUCLEAR REGULATORY COMMISSION, Fracture Toughness Criteria of Base Material for Ferritic Steel Shipping Cask Containment Vessels with a Maximum Wall Thickness of 4 Inches (0.1 m), Regulatory Guide 7.11, USNRC, Washington, DC (1991).
- [V.9] AMERICAN SOCIETY FOR TESTING AND MATERIALS, ASTM A208 Withdrawn 1941: Method of Test for Uniformity of Coating by the Preece Test (Copper Sulfate Dip) on Zinc or Steel Articles, Replaced by ASTM A239, ASTM, Philadelphia, PA (2009).
- [V.10] ROLFE, S.T., BARSOM, J.M., Fracture and fatigue control in structures, Prentice-Hall, Englewood Cliffs, NJ (1977).
- [V.11] HOLMAN, W.R., LANGLAND, R.T., Recommendations for Protecting Against Failure by Brittle Fracture in Ferritic Steel Shipping Containers up to Four Inches Thick, Rep. NUREG/CR-1815, Nuclear Regulatory Commission, Washington, DC (1981).
- [V.12] SCHWARTZ, M.W., Recommendations for Protecting Against Failure by Brittle Fracture in Ferritic Steel Shipping Containers Greater than Four Inches Thick, Rep. NUREG/CR-3826, Nuclear Regulatory Commission, Washington, DC (1984).
- [V.13] AMERICAN SOCIETY OF MECHANICAL ENGINEERS, Boiler and Pressure Vessel Code, Section III, Division 1 — Appendices, Appendix G: Protection Against Nonductile Failure, ASME, New York (1992).

- [V.14] ASSOCIATION FRANÇAISE POUR LES RÈGLES DE CONCEPTION ET DE CONSTRUCTION DES CHAUDIÈRES ÉLECTRONUCLÉAIRES (AFCEN), French Nuclear Construction Code, RCC-MR: Design and Construction Rules For Mechanical Components of FBR Nuclear Islands, Framatome, Paris (1985, with addendum 1987).
- [V.15] MINISTRY FOR INTERNATIONAL TRADE AND INDUSTRY, Technical Criteria for Nuclear Power Structure, Notification No. 501, MITI, Tokyo (1980).
- [V.16] KERNTECHNISCHER AUSSCHUSS, Sicherheitstechnische Regeln des KTA, Komponenten des Primärkreises von Leichtwasserreaktoren, Teil 2: Auslegung, Konstruktion und Berechnung, KTA 3201.2, Fassung 11/2017, KTA Geschäftsstelle, Bundesamt für Strahlenschutz, Salzgitter, Germany (2017).
- [V.17] BRITISH STANDARDS INSTITUTION, Guidance on Methods for Assessing the Acceptability of Flaws in Fusion Welded Structures, PD 6493, BSI, London (1991).
- [V.18] RUSSIAN FEDERATION FOR STANDARDIZATION AND METROLOGY, Determination of Fracture Toughness Characteristics Under Static Loading, Rep. GOST 25.506-85, Moscow (1985); and Determination of Fracture Toughness Characteristics Under Dynamic Loading, Rep. R D-50-344-8, Moscow (1983).
- [V.19] AMERICAN SOCIETY FOR TESTING AND MATERIALS, Annual Book of ASTM Standards: Standard Test Method for Plane Strain Fracture Toughness of Metallic Materials, Vol. 03.01, ASTM E399-83, ASTM, Philadelphia, PA (1983).
- [V.20] JAPAN SOCIETY OF MECHANICAL ENGINEERS, Standard Test Method for CTOD Fracture Toughness Testing, JSME S001, JSME, Tokyo (1981).
- [V.21] AMERICAN SOCIETY FOR TESTING AND MATERIALS, Standard Test Method for J_{Ic} , A Measure of Fracture Toughness, ASTM E813, Annual Book of ASTM Standards, Vol. 03.01, ASTM, Philadelphia, PA (1991).
- [V.22] BRITISH STANDARDS INSTITUTION, Fracture Mechanics Toughness Tests: Method for Determination of K_{Ic} , Critical CTOD and Critical J Values of Welds in Metallic Materials, BS 7448-2, BSI, London (1997).
- [V.23] AMERICAN SOCIETY FOR TESTING AND MATERIALS, Standard Test Method for Crack Tip Opening Displacement (CTOD) Fracture Toughness Measurement, ASTM E1290-93, Annual Book of ASTM Standards, ASTM, Philadelphia, PA (1993).
- [V.24] JAPAN WELDING ENGINEERING SOCIETY, Standard Test Method for CTOD Fracture Toughness Testing, JWES 2805, JWES, Tokyo (1980).
- [V.25] INTERNATIONAL ORGANIZATION FOR STANDARDIZATION, Metallic materials unified method of test for the determination of quasistatic fracture toughness, ISO 12135:2016, Geneva (2016).
- [V.26] ELECTRIC POWER RESEARCH INSTITUTE, EPRI Handbook on Elastic Plastic Fracture Mechanics Methods, EPRI, Palo Alto, CA.

- [V.27] CENTRAL ELECTRICITY GENERATING BOARD, Assessment of the Integrity of Structures Containing Defects, Rep. R/H/R6-Rev. 3, CEGB, London (1986).
- [V.28] AMERICAN SOCIETY OF MECHANICAL ENGINEERS, 2010 ASME Boiler and Pressure Vessel Code, Section XI: Rules for Inservice Inspection of Nuclear Power Plant Components, Includes 2011 Addenda Reprint/01-Jul-2010 ASME, New York (2010) 574 pp.
- [V.29] CENTRAL RESEARCH INSTITUTE OF THE ELECTRIC POWER INDUSTRY, Research on Quality Assurance of Ductile Cast Iron Casks, Rep. EL 87001, CRIEPI, Tokyo (1988).
- [V.30] DROSTE, B., SORENSON, K. (Eds), Brittle fracture safety assessment, Int. J. Radioact. Mater. Transp. **6** 2–3 (1995) 101–223.
- [V.31] SHIRAI, K., et al., Integrity of cast iron cask against free drop test: Verification of brittle failure design criterion, Int. J. Radioact. Mater. Transp. **41** (1993) 5–13.
- [V.32] ARAI, T., et al., Determination of Lower Bound Fracture Toughness for Heavy Section Ductile Cast Iron (DCI) and Small Specimen Tests, ASTM STP No. 1207, American Society for Testing and Materials, Philadelphia, PA (1995) 355–368.

Appendix VI

CRITICALITY SAFETY ASSESSMENTS

INTRODUCTION

VI.1. This appendix offers general advice on the demonstration of compliance with the requirements established in paras 673–686 of the Transport Regulations for packages containing fissile material. The performance and documentation of a thorough criticality safety assessment provide the necessary demonstration of compliance. The documentation of the criticality safety assessment (to be included in the package design safety report (PDSR)) is an essential part of the application for approval submitted to the competent authority. This criticality safety assessment should be performed by the application of suitable management system procedures at all stages, as required by para. 815 of the Transport Regulations.

VI.2. Although criticality safety assessments can sometimes be developed using safe subcritical limits for mass or dimensions (examples can be found in Refs [VI.1–VI.6]), computational analyses are more commonly used to provide the bases. Thus, this appendix provides recommendations on the analytical approach that should be considered and the documentation that should be provided to demonstrate compliance with the criticality safety requirements in paras 673–686. The basis for acceptance of the calculated results for establishing subcriticality for regulatory compliance is considered.

PACKAGE DESCRIPTION

VI.3. The criticality section of the PDSR for a transport package should include a description of the packaging and its contents. This description should focus on the package dimensions and material components that can influence reactivity (e.g. fissile material inventory and placement, neutron absorber material and placement, reflector materials) rather than structural information, such as bolt placement and trunnions. Engineering drawings and design descriptions should be invoked to specify the details of manufactured components.

VI.4. The PDSR should clearly state the full range of contents for which approval is requested. Thus, the parameter values (e.g. U-235 enrichment, multiple assembly types, UO₂ pellet diameter) needed to ensure that the packaging contents are within prescribed limits should be provided. For packages with multiple loading configurations, each configuration should also be specifically described, including possible partial load configurations. The description of the contents should include:

- (a) The types of material (e.g. fissile and non-fissile isotopes, reactor fuel assemblies, packaging material and neutron absorbers);
- (b) The physical form and chemical composition of the materials (e.g. gases, liquids, and solids as metals, alloys or compounds);
- (c) The quantity of material (e.g. masses, densities, U-235 enrichment and isotopic distribution);
- (d) Other physical parameters (e.g. geometric shapes, configurations, dimensions, orientation, spacing and gaps).

VI.5. The criticality section of the PDSR should include a description of the packaging, with emphasis on the design features pertinent to the criticality safety assessment. The features that should be emphasized are:

- (a) The materials used in construction and their relevance to criticality safety;

- (b) Pertinent dimensions and volumes (internal and external);
- (c) The limits on design features relied on for criticality safety;
- (d) Packaging materials that act as a moderator for neutrons, including hydrogenous materials with a higher hydrogen density than water (e.g. polyethylene, plastic wrappers) or significant quantities of beryllium, carbon or deuterium;
- (e) Other design features that contribute to criticality safety (e.g. those that prevent in-leakage of water subject to conditions of paras 680 and/or 683(b), as appropriate).

VI.6. The portion of the packaging and contents that forms the confinement system should be carefully described. A statement of tests that have been performed (or analysed), together with the results or evidence of the tests, should be provided to establish the effects on the package (and confinement system) of the normal conditions of transport (see para. 684(b)) and the accident conditions of transport (see para. 685(b)). For packages transported by air, the effects of any tests required by para. 683(a) should be considered. Any potential change to the physical or chemical form of the contents, as well as the contingencies of para. 673(a), should be considered in reviewing the test results.

CRITICALITY SAFETY ANALYSIS MODELS

VI.7. The description of the contents, packaging, confinement system and tests results should be used to formulate the package models needed for the analysis of criticality safety to demonstrate compliance with the requirements of paras 673–686. For each evaluation, one or more calculational models may need to be developed. An exact model of the package may not be necessary; a demonstrated bounding model may be adequate. However, the calculational models should explicitly include the physical features important to criticality safety and should be consistent with the package configurations following the tests prescribed in paras 682–685. Any differences (e.g. in dimensions, material, geometry) between the calculational models and the actual package configurations should be identified and justified. Also, the PDSR should discuss and explain how identified differences affect the analysis.

VI.8. Four calculational model types may be considered: contents models, single package models, package array models and material escaping models. The contents models should include all geometric and material regions that are within the defined confinement system. Additional calculational models may be needed to describe the range of contents or the various array configurations or damage configurations that should be analysed (see paras VI.40–VI.43).

VI.9. Sketches that are consistent with the engineering drawings should be provided for the models, or portions of the models, as appropriate. Any differences with the engineering drawings, or with other illustrations in the application, should be noted and explained. For each model, the drawings could be simplified by limiting the dimensional features on each sketch and by providing multiple drawings as needed, with each building on the previous one.

VI.10. The criticality section of the PDSR should address the dimensional tolerances of the packaging, including components containing neutron absorbers. When developing the calculational models, tolerances that tend to add conservatism (i.e. produce higher reactivity values) should be included. Subtracting the tolerance from the nominal wall thickness should be conservative for array calculations and have no significant effect on the single package calculation.

VI.11. The range of material specifications (including any uncertainties) for the packaging and contents should be addressed in the criticality section of the PDSR. Specifications and uncertainties for all fissile materials, neutron absorbing materials, materials of construction and moderating materials should be consistent with the engineering drawings of the packaging and the specified contents criteria. The range

of material specifications and associated uncertainties should be used to select parameters that produce the highest reactivity in accordance with the requirements of para. 676. For example, for each calculational model, the atom density of any neutron absorber (e.g. boron, cadmium or gadolinium) added to the packaging for criticality control should be limited to that verified by chemical analysis or neutron transmission measurements, in accordance with the requirements of para. 501.

VI.12. In practice, the effect of small variations in dimensions or material specifications may also be considered by determining a reactivity allowance that covers the reactivity change due to the parameter changes under consideration. This additional reactivity allowance should be positive.

VI.13. It is helpful to include a table that identifies all different material regions in the criticality safety calculational models. This table should list the following, as appropriate, for each region:

- The material;
- The density of the material;
- The constituents of the material;
- The weight (per cent) and atom density of each constituent;
- The region mass represented by the model, and the actual mass of the region (consistent with the contents and packaging description discussed in paras VI.3–VI.6).

METHOD OF ANALYSIS

VI.14. The PDSR should provide sufficient information or references to demonstrate that the computer code, nuclear cross-section data and technique used to complete the criticality safety assessment are adequate. The computer codes used in the safety assessment should be identified and described in the PDSR, or adequate references should be included. Verification that the software is performing as expected is important. The PDSR should identify or reference all hardware and software (titles and versions) used in the calculations, as well as pertinent version control information. Correct installation and operation of the computer code and associated data (e.g. cross-sections) should be demonstrated by performing and reporting the results of the sample problems or general validation problems provided with the software package. Capabilities and limitations of the software that are pertinent to the calculational models should be discussed, with particular attention given to discussion of the limitations that may affect the calculations.

VI.15. Computational methods that directly solve forms of the Boltzmann transport equation to obtain k_{eff} are preferred for use in the criticality safety analysis. The deterministic discrete ordinates technique and the Monte Carlo statistical technique are the typical solution formulations used by most criticality analysis codes. Monte Carlo analyses are prevalent because these codes can better model the geometry detail needed for most criticality safety analyses. Well documented and well validated computational methods may require less description than a limited use and/or unique computational method. The use of codes that solve approximations to the Boltzmann equation (e.g. diffusion theory) or use simpler methods to estimate k_{eff} should be justified.

VI.16. When using a Monte Carlo code, the criticality safety assessor should consider the imprecise nature of the k_{eff} value provided by the statistical technique. Every k_{eff} value should be reported with a standard deviation, σ . Typical Monte Carlo codes provide an estimate of the standard deviation of the calculated k_{eff} . For some situations, the analyst may wish to obtain a better estimate for the standard deviation by repeating the calculation with different valid random numbers and using this set of k_{eff} values to determine σ . Also, the statistical nature of Monte Carlo methods makes it difficult to use in

determining small changes in k_{eff} due to problem parameter variations. To indicate a trend in k_{eff} , the change in k_{eff} due to a parameter change should be statistically significant.

VI.17. The geometry model limitations of deterministic, discrete ordinates methods typically restrict their applicability to the calculation of bounding, simplified models and to the investigation of the sensitivity of k_{eff} to changes in system parameters. These sensitivity analyses can use a model of a specific region of the full problem (e.g. a fuel pin or homogenized fissile material unit surrounded by a detailed basket model) to demonstrate changes in reactivity with small changes in model dimensions or material specification. Such analyses should be used when necessary to ensure or demonstrate that the full package model has utilized conservative assumptions relative to calculation of the k_{eff} value of the system. For example, a one dimensional fuel pin model may be used to demonstrate the reactivity effect of tolerances in the cladding thickness.

VI.18. The calculational method employs both the computer code and the neutron cross-section data used by the code. The criticality safety assessment should be performed using cross-section data that are derived from measured data involving the various neutron interactions (e.g. capture, fission and scatter). Unmodified data processed from compendiums of evaluated nuclear data should be considered as the general sources of such data. The source of the cross-section data, any processing performed to prepare the data for analysis and any pertinent references that document the content of the cross-section library and its range of applicability should be traceable through the PDSR. Known limitations that may affect the analyses should be discussed (e.g. omission or limited range of resonance data, limited order or scattering).

VI.19. The PDSR should provide a discussion to help ensure that the k_{eff} values calculated by the code are suitably accurate. Adequate problem dependent treatment of multigroup cross-sections, use of sufficient cross-section energy groups (multigroup) or data points (continuous energy), and proper convergence of the numerical results are examples of issues the applicant may need to review and discuss in the PDSR. To the degree allowed by the code, the applicant should demonstrate or discuss any checks made to confirm that the calculational model prepared for the criticality safety analysis is consistent with the code input. For example, code generated plots of the geometry models and outputs of material masses by region may be beneficial in this confirmation process.

VI.20. The statistical nature of Monte Carlo calculations results in there being few rules, criteria or tests for judging when calculational convergence has occurred. However, some codes do provide guidance on whether convergence has occurred. Thus, the analyst may need to discuss the code output or other measures used to confirm the adequacy of convergence. For example, many Monte Carlo codes provide output edits that should be reviewed to determine adequate convergence. In addition, all significant code input parameters or options used in the criticality safety analysis should be identified and discussed in the PDSR. For a Monte Carlo analysis, these parameters should include the neutron starting distribution, the number of histories tracked (e.g. number of generations and particles per generation), boundary conditions selected, any special reflector treatment, and any special biasing option. For a discrete ordinates analysis, the spatial mesh used in each region, the angular quadrature used, the order of scatter selected, the boundary conditions selected, and the flux and/or eigenvalue convergence criteria should be specified.

VI.21. Code documentation and literature references are sources of information used to obtain practical data on the uncertainties associated with Monte Carlo codes used to calculate k_{eff} and to give advice on output features and trends that should be observed. If convergence problems were encountered by the applicant, a discussion of the problem and the steps taken to obtain an adequate k_{eff} value should be provided. For example, calculational convergence may be achieved by selecting a different neutron starting distribution or running additional neutron histories. Modern computers allow a significant number of particle histories to be tracked.

VALIDATION OF CALCULATIONAL METHOD

VI.22. The application for approval of a transport package should demonstrate that the calculational method (codes and cross-section data) used to establish criticality safety has been validated against measured data that can be shown to be applicable to the package design characteristics. The validation process should provide a basis for the reliability of the calculational method and should justify the value that is considered the subcritical limit for the packaging system.

VI.23. Available guidance [VI.5, VI.7] for performing and documenting the validation process indicates that:

- (a) Bias and uncertainties should be established through comparison with critical experiments that are applicable to the package design.
- (b) The range of applicability for the bias and uncertainty should be based on the range of parameter variation in the experiments.
- (c) Any extension of the range of applicability beyond the experimental parameter field should be based on trends in the bias and uncertainty as a function of the parameters and use of independent calculational methods.
- (d) An upper subcritical limit for the package should be determined on the basis of the established bias and uncertainties and a margin of subcriticality.

VI.24. Although significant reference material is available to demonstrate the performance of many different criticality safety codes and cross-section data combinations, the PDSR should still demonstrate that the specific (e.g. code version, cross-section library and computer platform) calculational method used by the applicant is validated in accordance with the above process and taking into account the requirements for a management system at all stages of the assessment.

VI.25. The first phase in the validation process should be to establish an appropriate bias and uncertainty for the calculational method by using well defined critical experiments that have parameters (e.g. materials, geometry) that are characteristic of the package design. The single package configuration, the array of packages and the normal conditions of transport and accident conditions of transport should be considered in selecting the critical experiments for the validation process. Ideally, the set of experiments should match the package characteristics that most influence the neutron energy spectrum and reactivity. These characteristics include:

- (a) The fissile isotope(s) (U-233, U-235, Pu-239 and Pu-241 according to the definition of para. 222), form (homogeneous, heterogeneous, metal, oxide, fluoride) and isotopic composition of the fissile material;
- (b) Hydrogenous moderation consistent with optimum conditions in and between packages (if substantial amounts of other moderators, such as carbon or beryllium, are in the package, then these should also be considered);
- (c) The type (e.g. boron, cadmium), placement (between, within, or outside the contents) and distribution of absorber material and materials of construction;
- (d) The single package contents configuration (e.g. homogeneous or heterogeneous) and packaging reflector material (lead, steel);
- (e) The array configuration, including spacing, interstitial material and number of packages.

VI.26. It is unlikely that the complete combination of package characteristics will be found from available critical experiments, and critical experiments for large arrays of packages do not currently exist. Thus, a sufficient variety of critical experiments should be modelled in order to demonstrate that the calculational method adequately predicts k_{eff} for each individual experiment. The experiments selected should have characteristics that are judged to be important to the k_{eff} of the package (or array of packages) under normal and accident conditions.

VI.27. The critical experiments that are selected should be briefly described in the PDSR, with references provided for detailed descriptions. The PDSR should indicate any deviation from the reference experiment description, including the basis for any such deviation (e.g. discussions with the experimenter, experiment log books). Since validation and supporting documentation may result in a very long report, it is normally acceptable to summarize the results in the PDSR and reference the validation report.

VI.28. For validation using critical experiments, the bias in the calculational method is the difference between the calculated k_{eff} value of the critical experiment and unity, although experimental errors and the use of extrapolation may be taken into consideration. Typically, a calculational method is deemed to have a positive bias if it overpredicts the critical condition (i.e. calculated $k_{\text{eff}} > 1.0$) and a negative bias if it underpredicts the critical condition (i.e. calculated $k_{\text{eff}} < 1.0$). A calculational method should have a bias that either has no dependence on a characteristic parameter, or else is a smooth, well behaved function of characteristic parameters. Wherever possible, a sufficient number of critical experiments should be analysed to determine trends that may exist using parameters important in the validation process (e.g. hydrogen to fissile ratio (H/X), U-235 enrichment, neutron absorber material). The bias for a set of critical experiments should be taken as the difference between the best fit of the calculated k_{eff} data and 1.0. Where trends exist, the bias will not be constant over the parameter range. If no trends exist, the bias will be constant over the range of applicability. For trends to be recognized, they need to be statistically significant, both in terms of the calculational uncertainties and the experimental uncertainties.

VI.29. The criticality safety analyst should consider three general sources of uncertainty: uncertainty in the experimental data, uncertainty in the calculational method and uncertainty due to the particular analyst and calculational models. Examples of uncertainties in experimental data are uncertainties reported in material or fabrication data or uncertainties due to an inadequate description of the experimental layout or simply due to tolerances on equipment. Examples of uncertainties in the calculational method are uncertainties in the approximations used to solve the mathematical equations, uncertainties due to solution convergence and uncertainties due to cross-section data or data processing. Individual modelling techniques, selection of code input options and interpretation of the calculated results are possible sources of uncertainty due to the analyst or calculational model.

VI.30. In general, all of these sources of uncertainty should be integrally observed in the variability of the calculated k_{eff} results obtained for the critical experiments. The variability should include the Monte Carlo standard deviation in each calculated critical experiment k_{eff} value, as well as any change in the calculated value arising from the consideration of experimental uncertainties. Thus, these uncertainties will be intrinsically included in the bias and uncertainty in the bias. This variation or uncertainty in the bias should be established by a valid statistical treatment of the calculated k_{eff} values for the critical experiments. Methods exist [VI.8] that enable the bias and uncertainty in the bias to be evaluated as a function of changes in a selected characteristic parameter.

VI.31. Calculational models used to analyse the critical experiments should be provided or adequate references to such discussions should be provided. Input data sets used for the analysis should be provided, along with an indication of whether these data sets were developed by the applicant or obtained from other identified sources (e.g. published references, databases). Known uncertainties in

the experimental data should be identified, along with a discussion of how, or if, they were included in the establishment of the overall bias and uncertainty for the calculational method. The statistical treatment used to establish the bias and uncertainty should be thoroughly discussed in the application and suitable references included, where appropriate.

VI.32. As an integral part of the code validation effort, the range of applicability for the established bias and uncertainty should be defined. The PDSR should demonstrate that, considering both normal and accident conditions, the package is within this range of applicability and/or the PDSR should define the extension of the range necessary to include the package. The range of applicability should be defined by identifying the range of important parameters and/or characteristics for which the code was (or was not) validated. The procedure or method used to define the range of applicability should be discussed and justified (or referenced) in the application for approval. For example, one method [VI.8] indicates the range of applicability to be the limits (upper and lower) of the characteristic parameter used to correlate the bias and uncertainties. The characteristic parameter may, for example, be defined in terms of the hydrogen to fissile ratio (e.g. H/X = 10–500), the average energy causing fission, the ratio of total fissions to thermal fissions (e.g. F/F_{th} = 1.0–5.0), or the U-235 enrichment.

VI.33. Use of the bias and uncertainty for a package with characteristics beyond the defined range of applicability is endorsed by consensus guidance [VI.5]. This guidance indicates that the extension should be based on trends in the bias as a function of system parameters and, if the extension is large, confirmed by independent calculational methods. However, the applicant should consider that extrapolation can lead to a poor prediction of actual behaviour. Even interpolation over large ranges with no experimental data can be misleading [VI.9]. The applicant should also consider the fact that comparisons with other calculational methods can illuminate a deficiency or provide concurrence. However, given discrepant results from independent methods, it is not always a simple matter to determine which result is ‘correct’ in the absence of experimental data [VI.10].

VI.34. The criticality safety analyst should recognize that there is currently no consensus guidance on what constitutes a ‘large’ extension, nor any guidance on how to extend trends in the bias. In fact, it is not just the trend in the bias that the assessor should consider, but the trend in the uncertainties and bias. The lack of experimental data near one end of a parameter range may cause the uncertainty to be larger in that region⁷. Proper extension of the bias and uncertainty means that the assessor should determine and understand the trends in the bias and uncertainty. The assessor should exercise extreme care in extending the range of applicability and provide a detailed justification of the need for an extension, along with a thorough description of the method and the procedure used to estimate the bias and uncertainty in this extended range.

VI.35. The criticality safety section of the PDSR should demonstrate how the bias and uncertainty determined from the comparison of the calculational method with critical experiments are used to establish a minimum k_{eff} value (i.e. upper subcritical limit) such that similar systems with a higher calculated k_{eff} are considered to be critical. The following general relationship for establishing the acceptance criteria is recommended:

$$k_c - \Delta k_u \geq k_{\text{eff}} + n\sigma + \Delta k_m \quad (\text{VI.1})$$

where

⁷ It should be noted that any extension of the uncertainty using the method in Ref. [VI.8] should consider the functional behaviour of the uncertainty as a function of the parameter, not just the maximum value of the uncertainty.

k_c is the critical condition (1.00);

Δk_u is an allowance for the calculational bias and uncertainty;

Δk_m is a required margin of subcriticality;

k_{eff} is the calculated value obtained for the package or array of packages;

n is the number of standard deviations taken into account (2 or 3 are common values);

σ is the standard deviation of the k_{eff} value obtained with Monte Carlo analysis.

Thus, the general relation can be rewritten as:

$$1.00 - \Delta k_u \geq k_{eff} + n\sigma + \Delta k_m \quad (\text{VI.2})$$

or

$$k_{eff} + n\sigma \leq 1.00 - \Delta k_m - \Delta k_u \quad (\text{VI.3})$$

VI.36. The maximum upper subcritical limit (USL) that should be used for a package evaluation is given by:

$$\text{USL} = 1.00 - \Delta k_m - \Delta k_u \quad (\text{VI.4})$$

VI.37. As noted previously, the bias can be positive (overpredict critical experiments) or negative (underpredict critical experiments). However, prudent criticality safety practice is to assume the uncertainties to be single sided uncertainties that lower the estimate of a critical condition and so, by definition, are always zero or negative. The Δk_u term used in this section represents the combined value of the bias and uncertainty and the applicant should normally define this term such that there is no increase in the value of the USL. Thus, k_u is the absolute value of the combined bias and uncertainty if the combined value is negative, or 0 if the combined value of the bias and uncertainty is positive.

VI.38. The value of the margin of subcriticality, Δk_m , used in the safety assessment is a matter of judgement, bearing in mind the sensitivity of k_{eff} to foreseeable physical or chemical changes to the package and the availability of an extensive validation study. For example, low enriched uranium systems may have a high k_{eff} value but exhibit almost insignificant changes in this value for conceivable changes in package conditions or fissile material quantities. Conversely, a system of high enriched uranium may exhibit significant changes in k_{eff} for rather small changes in the package conditions or fissile material quantity. Typical practice for transport packages is often to use a Δk_m value equal to 0.05 Δk . Although a value of Δk_m lower than 0.05 may be appropriate for certain packages, such lower values require justification based on available validation and a demonstrated understanding of the system and the effect of potential changes. The statistical method in Ref. [VI.8] provides an example of a technique that can be used to demonstrate that the selected value for Δk_m is adequate to the given set of critical experiments used in the validation. A lack of critical experiment data or the need to extend beyond the range of applicability [VI.5] may indicate the need to increase the margin of subcriticality beyond that typically applied.

VI.39. Information on potentially useful critical experiments, benchmark exercises and generic code validation reports can be found in Refs [VI.8, VI.11–VI.19].

CALCULATIONS AND RESULTS

General

VI.40. This section presents a logical, generic approach to the calculational effort that should be described in the PDSR. At least two series of calculational cases should be performed: (i) a series of single package cases in accordance with the requirements of paras 680–683, and (ii) a series of array cases in accordance with the requirements of paras 684 and 685. However, the number of calculations that need to be performed for the safety assessment will depend on the various parameter changes and the conditions that should be considered, the packaging design and features, the contents and the potential condition of the package under normal conditions and accident conditions. For the purposes of the safety assessment based on computational methods, the applicant should consider the term ‘subcritical’ (see paras 673 and 682–685) to mean that the calculated k_{eff} value (including any Monte Carlo standard deviation) is less than the USL defined in paras VI.22–VI.39.

VI.41. Calculations representing each of the different possible loading configurations (full and partial load configurations) should be provided in the PDSR. A single contents model that will encompass different loading configurations should only be considered if the justification is clear and straightforward. Sufficient calculations are needed to demonstrate that the fissile contents of a package are being considered in their most reactive configuration, consistent with their physical and chemical forms within the confinement system and the normal or accident conditions of transport, as appropriate. If the contents can vary over some parameter range (e.g. mass, enrichment, isotopic distribution, spacing), the criticality safety analysis should demonstrate that the model describes and uses the parameter specification that provides the maximum k_{eff} value for the conditions specified in paras 673–685. The content parameter values and/or content configurations that provide the maximum reactivity may vary depending on whether a single package or an array of packages is being analysed.

VI.42. For heterogeneous mixtures of fissile material, an optimum spacing between fissile lumps, such that maximum reactivity is achieved, should be assumed, unless adequate structure is provided to ensure a known spacing or spacing range (e.g. reactor fuel pins in an assembly). With complex systems, there are often competing factors and uniform spacing may not be the most reactive state possible. The contents models for packages that transport individual pellets should ensure that credible variations in pellet size and spacing are considered in reaching the optimum configuration that produces the maximum reactivity. Packages that transport waste containing fissile material should ensure that the limiting concentration of fissile material is used in the safety analysis. In accordance with para. 676, uncertainty in the contents is required to be addressed by setting the relevant parameter to its most conservative value (consistent with the range of possible values); in practice this may be achieved by including it in the consideration of the allowance for calculational uncertainties.

VI.43. With the number of calculations that may be needed, it is helpful to summarize the calculated results in a tabular form with a case identifier, a brief description of the conditions for each case and the case results. Additional information should be included in the table if it supports and simplifies the verbal description in the text. Ref. [VI.20] includes an example of a format recommended to summarize the results of single package and package array calculations. A similar format could be used to summarize the results for cases demonstrating that the limiting conditions are appropriately applied.

Single package analyses

VI.44. The single package analyses used to demonstrate subcriticality for the purposes of paras 682 and 683 should depict the packaging and contents in the most reactive configuration, consistent with the chemical and physical forms of the material and the requirement to consider (para. 682) or not consider (para. 683(a)) in-leakage of water. Other single package analyses may be needed to demonstrate intermediate configurations analysed to determine the most reactive configuration. Determination of the most reactive configuration should consider the following:

- (a) Change in internal and external dimensions due to impact;
- (b) Loss of material, such as neutron shield or wooden overpack due to the fire test;
- (c) Rearrangement of fissile material or neutron absorber material within the confinement system due to impact, fire or immersion;
- (d) Effects of temperature changes on the package material and/or the neutron interaction properties.

VI.45. Unless the special features described in para. 680 are provided, calculations for the single package should systematically investigate the various states of water flooding and package reflection (in accordance with the requirement of para. 681) representative of normal conditions and accident conditions of transport. If a package has multiple void regions, including regions within the confinement or containment system, the flooding of each region (and/or combinations of regions) should be considered. The case of the single package completely flooded and reflected should be considered. Variations in the flooding sequence should be considered by the applicant (e.g. partial flooding, variations caused by the package lying in horizontal or vertical orientation, flooding (moderating) at less than full density water, progressively flooding regions from the inside out).

VI.46. Paragraph 681 requires that in the assessment needed for para. 682, the confinement system be reflected closely on all sides by at least 20 cm of full density water, unless packaging materials that surround the confinement system provide for a higher k_{eff} . Thus, for routine and normal conditions of transport, analyses that consider confinement system reflection by water and package reflection by water is required to be evaluated to ascertain the condition of highest k_{eff} . For accident conditions of transport, if the confinement system is demonstrated as remaining within the package, reflection of the confinement system by water can be precluded and only water reflection of the package considered. A lead shield around the confinement system is an example of a packaging reflector that may provide greater reflection than water.

VI.47. Several single package analyses may be needed to assess the requirements of para. 683 in relation to packages to be transported by air, particularly if actual testing in accordance with paras 733 and 734 is not performed. In the absence of the appropriate tests, these analyses should be formulated to demonstrate that no arrangement could arise where the single package could be critical, assuming no addition of water to the package materials. The results of the single package calculations can influence the approach and the number of calculations necessary for the array series calculations, particularly if there are different content loading configurations.

Assessment of package arrays

VI.48. The package array models should depict the arrangements of packages that are used in the calculations and that are necessary to fulfil the requirements of paras 684 and 685. At least two array models are needed: (i) an array of packages consistent with the normal conditions of transport, and (ii) an array of packages following the accident conditions of transport. The number 'N' may be less than unity, in which case the package would have a CSI of more than 50. The configuration of the individual packages (consistent with normal conditions of transport and with accident conditions of transport) used in the respective array models should be consistent with (but not necessarily identical to) the respective single package models discussed in paras VI.44–VI.47 (e.g. leakage needs to be minimized in the single package model, but interactions between the packages may need to be maximized in the array model).

VI.49. The treatment of array moderation can be easy or complex, depending on the placement of the materials of construction and their susceptibility to damage from accident conditions. For all of these

conditions and combinations of conditions, the assessor should carefully investigate the optimum degree of internal and interspersed moderation consistent with the chemical and physical forms of the material and the packaging for normal and accident conditions of transport, and demonstrate that subcriticality is maintained. Numerous moderation conditions should be considered, including the following:

- (a) Moderation from packaging materials that are inside the primary containment system;
- (b) Moderation due to preferential flooding of different void regions in the packages;
- (c) Moderation from materials of construction (e.g. thermal insulation and neutron shielding);
- (d) Moderation in the region between the packages in an array.

VI.50. Under normal conditions of transport, the analyses should consider only the moderators present in the package (items (a)–(c) above); the analyses is required to consider that there is nomoderation between packages (item (d) above) — for example from mist, rain, snow, foam and flooding— in accordance with the requirements in para. 684 (a). In determining the CSI of an array of packages consistent with accident conditions of transport, the applicant should carefully consider all four of the above conditions, including how each form of moderation can change. As an example, consider a package with thermally degradable insulation and thermal neutron poison material. For normal conditions of transport, the analysis should include the insulation. For accident conditions, the applicant should investigate the effects of reduced moderation as a result of the thermal test. If the inner containment system of this example package does not prevent water in-leakage, the applicant should carefully evaluate the varying degrees of moderation in the containment. The effect that the neutron poison has on the system reactivity will also change as the degree of moderation varies.

VI.51. Optimum moderation should be considered in each calculation, unless it is demonstrated that there would be no leakage of water into void spaces under the appropriate test conditions. Optimum moderation is the condition that provides the maximum k_{eff} value for the array (this is likely to be a different degree of moderation than for the optimum single package condition). Partial and preferential flooding should be considered in determining optimum moderation conditions. If there is no leakage of water into the system, the actual internal moderation provided by the materials in the package can be assumed in the array model. Similarly, if the moderator provides more than optimum moderation and owing to its physical and chemical forms cannot leak from the containment vessel, then its moderating properties can be considered in the model. For example, a solid moderator that is shown to overmoderate the fissile material can be considered in the calculational model if its presence is verified. This criterion on moderation should be assessed and separately applied for normal conditions of transport and accident conditions of transport.

VI.52. Each model for arrays of packages consistent with normal conditions of transport should assume a void between the packages consistent with the requirement of para. 684(a). For the assessment of arrays of packages consistent with accident conditions of transport in accordance with para. 685, this optimum interspersed hydrogenous moderation condition should be determined. Optimum is considered the hydrogenous condition that provides the highest k_{eff} value. Interspersed moderation should be considered as being that moderation which separates one package in the array from another package. This interspersed moderation should not be taken to include the moderation within the package. Thus, if the packaging provides interspersed moderation greater than that shown to be optimum, the greater amount may be assumed in the calculational model.

VI.53. The sensitivity of the neutron interaction between packages varies with the package design. For example, small, lightweight packages are more susceptible to high neutron interaction than large, heavy packages (e.g. irradiated nuclear fuel packages). Since variations in internal water moderation and

interspersed water need to be considered for each arrangement of packages, the process can be tedious without proper experience to guide the selection of analyses. It is helpful to provide a plot of the k_{eff} value as a function of the moderator density between packages.

VI.54. In preparing the plot described in para. VI.53, the first step is to determine the optimum moderation of the array of packages consistent with the results of the accident tests. As water is added to the region between packages, the spacing of the packages may limit the quantity of moderator that can be added. For this reason, it is sometimes convenient to model an infinite array of packages using an array unit cell consisting of the individual package and a tight fitting repeating boundary. If the k_{eff} response to increasing interspersed moderator density for this array with the units in contact has an upward trend (positive slope) at full density moderation, the applicant should consider increasing the size of the unit cell and recalculating k_{eff} as a function of moderation density. Increasing the size of the unit cell provides an increased edge to edge spacing between packages and makes more volume available for the interspersed moderator. This progressive procedure should only be stopped after confirming that the packages are isolated and that added interstitial water is only providing additional water reflection.

VI.55. All credible combinations of density and spacing variation that may cause a higher k_{eff} value to be calculated should be considered and a discussion should be provided in the PDSR demonstrating that the maximum k_{eff} value has been determined. Figure VI.1 depicts some examples of plots of k_{eff} versus interspersed water moderator density illustrating the moderation, absorption and reflection characteristics that may be encountered in packaging safety assessments. Curves A, B and C represent arrays for which an array of packages is overmoderated and increasing water moderation only lowers (curves B and C), or has no effect (curve A), on the k_{eff} value. Curves D, E and F represent arrays for which the array is undermoderated at zero water density, and increasing the interspersed moderator density causes the k_{eff} value to increase. Then, as the water density increases further, neutron absorption comes into effect, neutron interaction between packages decreases and the k_{eff} value levels out (curve D) or decreases (curves E and F). These peaking effects, such as those visible in curves E and F, can occur at very low moderator density (e.g. 0.001–0.1 fraction of full density). Therefore, care should be taken when selecting the values of interspersed moderator density in the calculation of the maximum k_{eff} value. It should be noted that the single package calculation only requires 20 cm of water reflection; thus, for a well spaced array (more than 20 cm), the accident condition array may produce a higher k_{eff} for an individual package than the single package model (this depends on the effects of the phenomena described in paras 680 and 681 and that needs to be considered). Curve G represents an array where the optimum interspersed moderator density has not been achieved even with full water density. For this situation, the applicant should increase the centre to centre spacing of the packages in the array, and all cases should be recalculated.

VI.56. The objective of the package array calculations is to obtain the information needed to determine the CSI for criticality control, as required by para. 686. The assessor may consider beginning the array calculations with an infinite array model. Successively smaller finite arrays may be required until the array sizes for normal conditions and for accident conditions of transport are found to be below the USL. As an alternative, an applicant may initiate the analyses using any array size, for example, one that is based on the number of packages planned to be shipped on a vehicle.

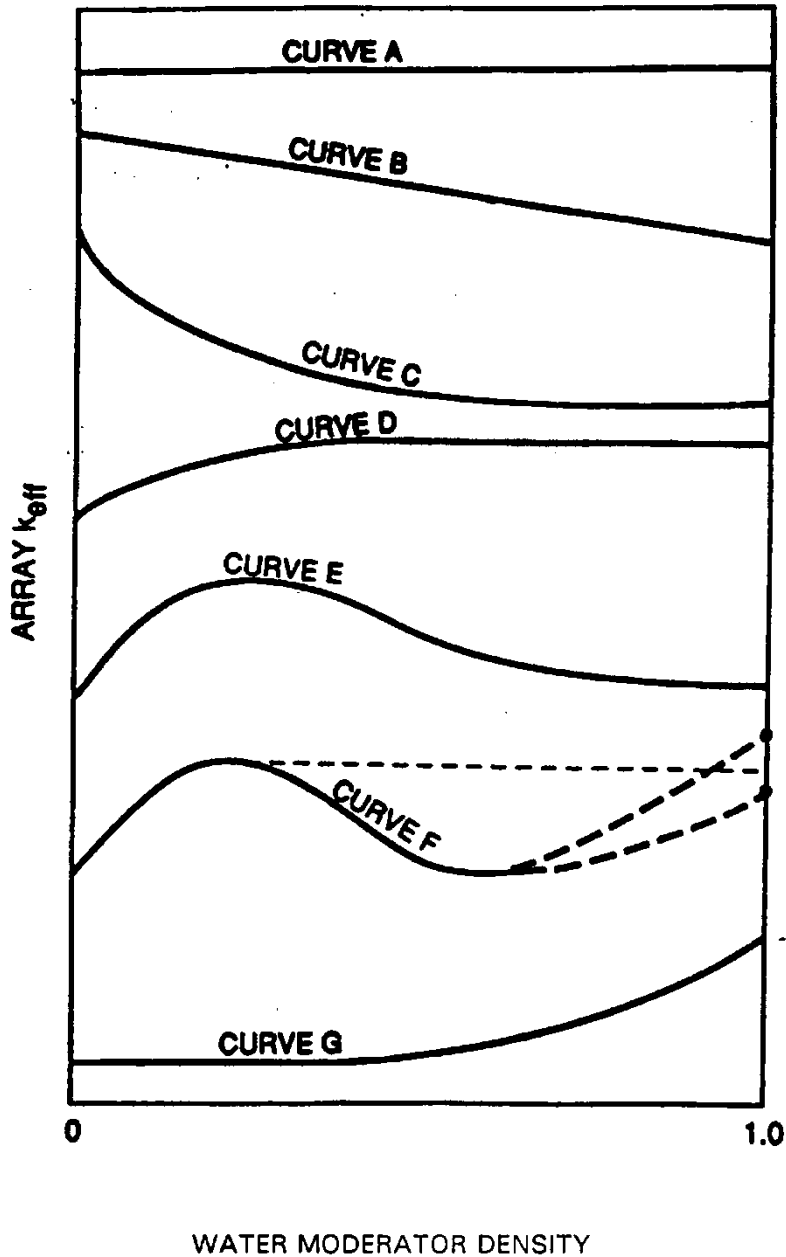

FIG. VI.1. Typical plots of array k_{eff} versus interspersed water moderator density.

VI.57. Care should be taken that the most reactive array configuration of packages has been considered in the criticality safety assessment. In investigating different array arrangements, the competing effects of leakage from the array system and interaction between packages in the array should be considered. Array arrangements that minimize the surface to volume ratio decrease leakage and should, in simple terms, maximize k_{eff} . Preferential geometric arrangement of the packages in the array should be considered. For example, for some packages (e.g. with the fissile material loaded off-centre), the need to optimize the interaction may mean that an array is more reactive when packages are grouped in a single or double layer. The effect of the external water reflector also needs to be considered. For some array cases, there may be little moderator present within the array, so increasing the surface area may lead to more moderation and, possibly, higher reactivity. The exact package arrangement may be represented by a simplified arrangement if adequate justification is provided. For example, it has been

shown that a triangular pitch arrangement of packages can, in simple cases, be represented by using an appropriately modified package model within a square pitch lattice arrangement [VI.20]. In more complex cases (even for cuboidal packages), the effect of having a triangular pitch may be important, since interaction between three triangularly pitched packages could be a dominant factor. Since there are so many competing effects, any simplifications made in the assessment need to be justified; something that is obvious from the point of view of array leakage may not be as obvious from the point of view of package interaction. All finite arrays of packages should be reflected on all sides by a close fitting, full density water reflector at least 20 cm thick.

VI.58. The CSI should be determined in accordance with the requirements of para. 686 and the information from the array analyses on the number of packages that will remain subcritical (below the USL) under normal conditions and under accident conditions of transport.

SPECIAL ISSUES

VI.59. Designers seeking to reduce conservatism in the criticality safety aspects of transport packages should carefully consider criticality safety issues throughout the entire design process. The large number of variables that can be important can lead to a very large number of calculations. It is therefore in the interests of the assessor to interact effectively with other members of the package design and manufacturing teams to reduce the variables that need to be considered in the assessment and to ensure adequate input on criticality safety issues. The difficulty in reducing the bounding conservatism traditionally used in criticality safety often arises in confirming the performance of the package under accident conditions and demonstrating the effect that this performance would have on criticality safety. Interaction with members of the design team responsible for structural, material and containment aspects of the package design is essential in order for the criticality safety analyst to obtain the knowledge required for making defensible assumptions for the calculational model. The experience and knowledge of the criticality safety assessor is also crucial to ensuring that an efficient, yet complete, assessment is performed and documented.

VI.60. Design options that depend on limiting mass, dimensions or concentration are often needed for safety, but are often a low priority design option because of payload reductions. Similarly, control by separation of fissile material takes too much valuable package space. The design option to provide special features to prevent water in-leakage is an attractive alternative to eliminate the consideration of water in a criticality assessment, but the design and demonstration of special features can be very difficult and lead to a prolonged review process. Thus, use of fixed neutron poisons remains the major option to help ensure criticality safety. To increase loadings for the large quantities of irradiated nuclear fuel being transported, the isotopic composition of nuclear fuel resulting from irradiation can be used as an alternative to the fresh (unirradiated) isotopic composition values used in the traditional, bounding approach to criticality safety assessment of irradiated nuclear fuel packages.

Credit for irradiation history (burnup credit)

VI.61. For the transport of irradiated (e.g. irradiated to near design burnup) nuclear fuel, the traditional design basis has been to use the isotopic compositions of the fresh, unirradiated fuel in the criticality safety evaluation. This approach is straightforward, relatively easy to defend and provides a conservative margin that typically precludes most concerns about misloading events.

VI.62. Transport of irradiated nuclear fuel with longer cooling times and the need to consider higher initial enrichments have caused criticality safety to become a more limiting design issue for irradiated nuclear fuel packages. Thus, to handle increased irradiated nuclear fuel capacity in new designs and to enable higher initial enrichments in existing packages, the concept of taking credit for the reduced reactivity caused by the irradiation or burnup of the irradiated nuclear fuel becomes an attractive design alternative to the fresh fuel assumption. The concept of considering the change in fuel inventory, and

thus a reduction in reactivity, resulting from irradiated nuclear fuel burnup is referred to as ‘burnup credit’. However, several issues need to be addressed and resolved before using an irradiated fuel isotopic composition in the design basis analyses for the criticality safety evaluation. These issues include:

- (a) Validation of analysis tools and associated nuclear data to demonstrate their applicability in the area of burnup credit;
- (b) Specification of design basis analyses that ensure the prediction of a bounding value of k_{eff} ;
- (c) Operational and administrative controls that ensure the irradiated nuclear fuel loaded into a package has been verified as meeting the loading requirements specified for that package design.

VI.63. The use of an irradiated nuclear fuel isotopic composition in the criticality safety analysis means that any computational methods used to predict this composition should be validated, preferably against measured data. The reduced reactivity in irradiated nuclear fuel is due to the decrease in fissile inventory and the increase in parasitic, neutron absorbing nuclides (non-fissile actinides and fission products) that build up during burnup. Refs [VI. 21, VI.22] provide information to help identify the important nuclides that affect the reactivity of irradiated fuel from pressurized water reactors. The irradiated nuclear fuel nuclides that can be omitted from a safety analysis are the parasitic absorbers that can only decrease k_{eff} if included in the analysis. Neutron absorbers that are not intrinsic to the fuel material matrix (e.g. gases) should also be eliminated.

VI.64. After selection of the nuclides to be used in the safety analysis, the validation process should begin. Compendiums of measured isotopic composition data have been produced [VI.23–VI.25], and efforts have been made to validate computational methods using data selected from these compendiums [VI.25–VI.27]. The measured isotopic data that are available for validation are limited. Of further concern is the fact that the database of fission product measurements is a small subset of the actinide measurements. In addition, the cross-section data for fission product nuclides have had much less scrutiny over broad energy ranges than most actinides of importance in irradiated nuclear fuel. Fission products can provide 20–30% of the negative reactivity from burnup, yet the uncertainties in their cross-section data and isotopic predictions reduce their effectiveness in safety assessments with burnup credit.

VI.65. The use of irradiated nuclear fuel isotopic composition has also raised validation issues in relation to the performance of computational methods in predicting k_{eff} . The concerns originate from the fact that no critical experiments using irradiated fuel in a transport package environment have been reported. Experimental data using actual irradiated fuel are necessary to demonstrate that:

- (a) The cross-section data of all nuclides, including those that are not present in fresh fuel are adequate for the prediction of k_{eff} ;
- (b) The variation in isotopic composition and its influence on k_{eff} can be adequately modelled;
- (c) The physics of particle interaction in irradiated nuclear fuel is handled adequately by the analysis methodology.

Sufficient relevant experimental data [VI.28–VI.31] should be considered in order to provide a basis for the validation of calculational methods applied in the PDSR for a package using burnup credit as a design basis assumption. Calculational benchmark exercises [VI.32–VI.34] that compare independent computational methods and data can also be valuable aids in understanding technical issues and in identifying potential causes of differences between predicted and measured data.

VI.66. The understanding of modelling and parameter uncertainties, together with proper incorporation of these uncertainties in the analysis assumptions, is necessary so that a bounding value of k_{eff} is calculated in the PDSR for a package that applies burnup credit. Many of these uncertainties should be examined as part of the validation process. For example, Ref. [VI.22] discusses a procedure to incorporate the variability in the analysis of measured isotopic data and the number of data points to provide a 'correction' factor that adjusts the irradiated nuclear fuel isotopic composition such that a conservative estimate of k_{eff} can be calculated.

VI.67. The isotopic composition of a particular fuel assembly in a reactor is dependent, to varying degrees, on the initial nuclide abundance, the specific power, the reactor operating history (including moderator temperature, soluble boron and assembly location in the reactor), the presence of burnable poisons or control rods and the cooling time after discharge. Seldom, if ever, are all of the irradiation parameters known to the safety analyst; typically, the analyst will have to demonstrate the criticality safety of a package for a specified initial enrichment, burnup, cooling time and assembly type. Data on the specific power, operating history, axial burnup distribution and presence of burnable poisons should be selected to ensure that the calculated irradiated nuclear fuel compositions will produce conservative estimates of k_{eff} . Identification of important reactor history parameters and their effect on irradiated nuclear fuel reactivity are discussed in Refs [VI.22, VI.35, VI.36]. Similarly, Refs [VI.22, VI.35] discuss the effect of the uncertainty in the axial burnup profile, and present information on the detail required in both the axial isotopic distribution and the numerical input parameters (e.g. number of neutron histories) in order to predict a reliable value of k_{eff} .

VI.68. The use of bounding uncertainties in the validation process and the analysis assumptions should provide assurance that the safety analysis is conservative for the range of initial enrichment, burnup, cooling time and assembly type. For a given assembly type and minimum cooling time (reactivity decreases with cooling time for the first 100 years or so), the safety analysis could provide a loading curve (see Fig. VI.2) that indicates the region of burnup and initial enrichment that ensures subcriticality.

DESIGN AND OPERATIONAL ISSUES

Use of neutron poisons

VI.69. Traditionally, neutron absorbing materials are divided into two categories: materials of construction and neutron poisons. Materials of construction are usually guaranteed to be present by virtue of their function. For this reason, the criticality safety assessor should ensure that the assessment conforms to the as-built package and that future modifications are reviewed and addressed for potential criticality issues. Fixed neutron poisons are intentionally added, to absorb neutrons, to reduce neutron reactivity or to limit neutron reactivity increases during abnormal conditions. The principal concern with reliance on neutron absorption by poisons (as opposed to reliance on neutron absorption by the materials of construction) is ensuring the presence of these poisons. Therefore, special attention is necessary to guarantee the presence and proper distribution of neutron absorbing material over the assumed life of the package. Physical, chemical and corrosive mechanisms should be considered as potential mechanisms for absorber loss. Loss of absorber material through direct neutron absorption (and, thus, transmutation to a non-absorbing isotope) is normally inconsequential because any measurable depletion would take millions of years of routine operation owing to the extremely low flux levels in a subcritical system.

VI.70. When neutron poisons are necessary, it is advisable to incorporate them as intrinsically as possible into the normal materials of construction and to verify their presence by a measurement. For example, boron fixed in an aluminium or steel matrix could be used for the inner container (basket) to reduce the neutron interaction between packages (provided it is structurally/thermally acceptable) or cadmium could be plated on to the inside surface of the inner container. However, verifying (and

perhaps reverifying at some frequency) that the absorbers are indeed present in the prescribed quantity and distribution is required to be addressed in the PDSR (see paras 501 and 503).

VI.71. If subcriticality of the shipment is dependent upon the presence of neutron absorbing materials that are an integral part of the contents (e.g. fissile waste with known absorbers or control rods in a fuel assembly), the burden of proof that the materials are present during normal and accident conditions is an important safety issue.

Pre-shipment measurements

VI.72. When burnup credit is used in the package assessment, operational and administrative controls are needed to establish that the irradiated nuclear fuel being loaded in the package is consistent with the characteristics assumed in the safety evaluation. Paragraph 677(b) of the Transport Regulations requires that a measurement is performed, and it is appropriate to link the assessment to this measurement. The assessment should show that the measurement is adequate for the purpose intended, taking into account the margins of safety and the probability of error (see paras 677.1–677.4). The measurement technique used should take into account the likelihood of misloading the fuel and the amount of available subcritical margin due to irradiation.

VI.73. An example of variability in measurement technique is provided in Ref. [VI.37], which specifies the use of a simple gamma detector measurement to verify burnup credit allowances for less than 5600 MW·d/MTU, but more direct measurement of fuel burnup for allowance of higher irradiation. This second measurement relies on two instruments that verify the reactor burnup records based on active and passive neutron measurements. In Refs [VI.38, VI.39], a similar measurement device has been demonstrated to be a practical method for determining if an assembly is within the ‘acceptable fuel region’ shown in Fig. VI.2. If the axial burnup profile is identified as an important characteristic of the spent nuclear fuel that is relied upon in the safety analysis, then similar measurement devices could also potentially be used to ascertain that the profile is within defined limits.

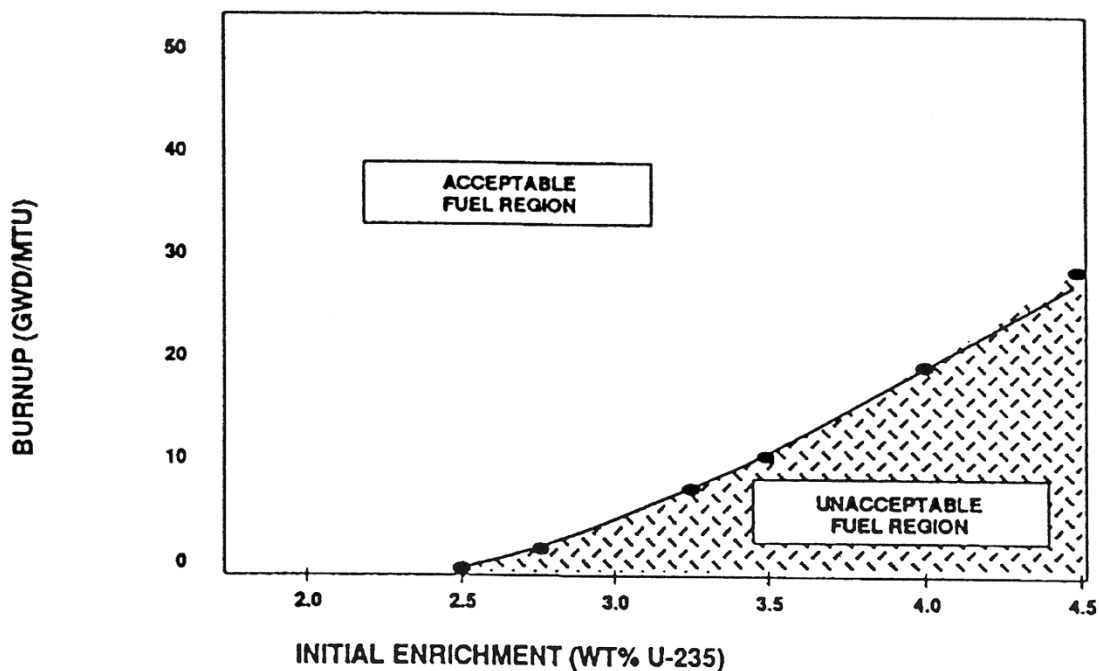

FIG. VI.2. Loading curve indicating the region of burnup and initial enrichment that ensures subcriticality.

REFERENCES TO APPENDIX VI

- [VI.1] PRUVOST, N.L., PAXTON, H.C., Nuclear Criticality Safety Guide, Rep. LA-12808, Los Alamos Natl Lab., Los Alamos, NM (1996).
- [VI.2] THOMAS, J.T. (Ed.), Nuclear Safety Guide TID-7016, Rev. 2, Rep. NUREG/CR-0095 (ORNL/NUREG/CSD-6), Nuclear Regulatory Commission, Washington, DC (1978).
- [VI.3] PAXTON, H.C., PRUVOST, N.L., Critical Dimensions of Systems Containing 235 U, 239 Pu, and 233 U, Rep. LA-10860-MS, Los Alamos Natl Lab., Los Alamos, NM (1987).
- [VI.4] JAPAN ATOMIC ENERGY RESEARCH INSTITUTE, Nuclear Criticality Safety Handbook (English Translation), JAERI-Review-95-013, JAERI, Tokyo (1995).
- [VI.5] AMERICAN NATIONAL STANDARDS INSTITUTE, Nuclear Criticality Safety in Operations with Fissionable Materials Outside Reactors, ANSI/ANS-8.1-1998, R2007 (R = Reaffirmed): American Nuclear Society, La Grange Park, IL (2007).
- [VI.6] AMERICAN NATIONAL STANDARDS INSTITUTE, Nuclear Criticality Control of Special Actinide Elements, ANSI/ANS-8.15-1981, R1987, R1995, R2005 (R = Reaffirmed), American Nuclear Society, La Grange Park, IL (2005).
- [VI.7] INTERNATIONAL ORGANIZATION FOR STANDARDIZATION, Nuclear Energy — Fissile Materials — Principles of Criticality Safety in Storing, Handling, and Processing, ISO 1709:1995, ISO, Geneva (1995).
- [VI.8] LICHTENWALTER, J.J., BOWMAN, S.M., DeHART, M.D., Criticality Benchmark Guide for Light-Water-Reactor Fuel in Transportation and Storage Packages, Rep. NUREG/CR-6361 (ORNL/TM-13211), Nuclear Regulatory Commission, Washington, DC (1997).
- [VI.9] PARKS, C.V., WRIGHT, R.W., JORDAN, W.C., Adequacy of the 123-Group Cross-Section Library for Criticality Analyses of Water-moderated Uranium Systems, Rep. NUREG/CR-6328 (ORNL/TM-12970), Nuclear Regulatory Commission, Washington, DC (1995).
- [VI.10] PARKS, C.V., JORDAN, W.C., PETRIE, L.M., WRIGHT, R.Q., Use of metal/uranium mixtures to explore data uncertainties, *Trans. Am. Nucl. Soc.* **73** (1995) 217.
- [VI.11] KOPONEN, B.L., WILCOX, T.P., HAMPEL, V.E., Nuclear Criticality Experiments From 1943 to 1978, an Annotated Bibliography: Vol. 1, Main Listing, Rep. UCRL-52769, Vol. 1, Lawrence Livermore Lab., CA (1979).
- [VI.12] BIERMAN, S.R., Existing Experimental Criticality Data Applicable to Nuclear Fuel Transportation Systems, Rep. PNL-4118, Battelle Pacific Northwest Lab., Richland, WA (1983).
- [VI.13] ORGANISATION FOR ECONOMIC CO-OPERATION AND DEVELOPMENT, International Handbook of Evaluated Criticality Safety Benchmark Experiments, Rep. NEA/NSC/DOC(95)03, Vols I–VI, OECD, Paris (1995).

- [VI.14] DURST, B.M., BIERMAN, S.R., CLAYTON, E.D., Handbook of Critical Experiments Benchmarks, Rep. PNL-2700, Battelle Pacific Northwest Lab., Richland, WA (1978).
- [VI.15] ORGANISATION FOR ECONOMIC CO-OPERATION AND DEVELOPMENT, Standard Problem Exercise on Criticality Codes for Spent LWR Fuel Transport Containers, CSNI Rep. No. 71 (Restricted), OECD, Paris (1982).
- [VI.16] ORGANISATION FOR ECONOMIC CO-OPERATION AND DEVELOPMENT, Standard Problem Exercise on Criticality Codes for Large Arrays of Packages of Fissile Materials, CSNI Rep. No. 78 (Restricted), OECD, Paris (1984).
- [VI.17] JORDAN, W.C., LANDERS, N.F., PETRIE, L.M., Validation of KENO V. A Comparison with Critical Experiments, Rep. ORNL/CSD/TM-238, Martin Marietta Energy Systems, Inc., Oak Ridge Natl Lab., TN (1994).
- [VI.18] Nuclear Criticality Safety, ICNC '91 (Proc. Conf. Oxford, 1991), 3 vols (1991).
- [VI.19] Nuclear Criticality Safety, ICNC '95 (Proc. Conf. Albuquerque, 1995), 2 vols, Univ. of New Mexico, Albuquerque, NM (1995).
- [VI.20] DYER, H.R., PARKS, C.V., ODEGAARDEN, R.H., Recommendations for Preparing the Criticality Safety Evaluation of Transportation Packages, Rep. NUREG/CR-5661 (ORNL/TM-11936), Nuclear Regulatory Commission, Washington, DC (1997).
- [VI.21] BROADHEAD, B.L., et al., Investigation of Nuclide Importance to Functional Requirements Related to Transport and Long-Term Storage of LWR Spent Fuel, Rep. ORNL/TM-12742, Oak Ridge Natl Lab., TN (1995).
- [VI.22] DeHART, M.D., Sensitivity and Parametric Evaluations of Significant Aspects of Burnup Credit for PWR Spent Fuel Packages, Rep. ORNL/TM-12973, Martin Marietta Energy Systems, Inc., Oak Ridge Natl Lab., TN (1996).
- [VI.23] NAITO, Y., KUROSAWA, M., KANEKO, T., Data Book of the Isotopic Composition of Spent Fuel in Light Water Reactors, Rep. JAERI-M 94-034, Japan Atomic Energy Research Institute, Tokyo (1994).
- [VI.24] BIERMAN, S.R., TALBERT, R.J., Benchmark Data for Validating Irradiated Fuel Compositions Used in Criticality Calculations, Rep. PNL-10045, Battelle Pacific Northwest Lab., Richland, WA (1994).
- [VI.25] KUROSAWA, M., NAITO, Y., KANEKO, T., "Isotopic composition of spent fuels for criticality safety evaluation and isotopic composition database (SFCOMPO)", Nuclear Criticality Safety, ICNC '95 (Proc. 5th Int. Conf. Albuquerque, 1995), Univ. of New Mexico, Albuquerque, NM (1995) 2.11-15.
- [VI.26] HERMANN, O.W., BOWMAN, S.M., BRADY, M.C., PARKS, C.V., Validation of the SCALE System for PWR Spent Fuel Isotopic Composition Analyses, Rep. ORNL/TM-12667, Oak Ridge Natl Lab., TN (1995).

- [VI.27] MITAKE, S., SATO, O., YOSHIKAWA, N., “An analysis of PWR fuel post irradiation examination data for the burnup credit study”, Nuclear Criticality Safety, ICNC '95 (Proc. 5th Int. Conf. Albuquerque, 1995), Univ. of New Mexico, Albuquerque, NM (1995) 5.18–25.
- [VI.28] BOWMAN, S.M., DeHART, M.D., PARKS, C.V., Validation of SCALE-4 for burnup credit applications, Nucl. Technol. 110 (1995) 53.
- [VI.29] GULLIFORD, J., HANLON, D., MURPHY, M., “Experimental validation of calculational methods and data for burnup credit”, Nuclear Criticality Safety, ICNC '95 (Proc. 5th Int. Conf. Albuquerque, 1995), Univ. of New Mexico, Albuquerque, NM (1995).
- [VI.30] SANTAMARINA, A., et al., “Experimental validation of burnup credit calculations by reactivity worth measurements in the MINERVE Reactor”, *ibid*, 1b.19–25.
- [VI.31] ANNO, J., FOUILLAUD, P., GRIVOT, P., POULLOT, G., “Description and exploitation of benchmarks involving ^{149}Sm , a fission product taking part in the burnup credit in spent fuels”, *ibid*, 5.10–17.
- [VI.32] TAKANO, M., OKUNO, H., OECD/NEA Burnup Credit Criticality Benchmark, Result of Phase IIA, Rep. NEA/NSC/DOC(96)01, Japan Atomic Energy Research Institute, Tokyo (1996).
- [VI.33] TAKANO, M., OECD/NEA Burnup Credit Criticality Benchmark, Results of Phase-IA, Rep. NEA/NSC/DOC(93)22, Japan Atomic Energy Research Institute, Tokyo (1994).
- [VI.34] DeHART, M.D., BRADY, M.C., PARKS, C.V., OECD/NEA Burnup Credit Calculational Criticality Benchmark — Phase IB Results, Rep. NEA/NSC/DOC(96)-06 (ORNL-6901), Oak Ridge Natl Lab., TN (1996).
- [VI.35] DeHART, M.D., PARKS, C.V., “Issues related to criticality safety analysis for burnup credit applications”, Nuclear Criticality Safety, ICNC '95 (Proc. 5th Int. Conf. Albuquerque, 1995), Univ. of New Mexico, Albuquerque, NM (1995) pp. 1b.26–36.
- [VI.36] BOWDEN, R.L., THORNE, P.R., STRAFFORD, P.I., “The methodology adopted by British Nuclear Fuels plc in claiming credit for reactor fuel burnup in criticality safety assessments”, *ibid*, 1b.3–10.
- [VI.37] ZACHAR, M., PRETESACQUE, P., Burnup credit in spent fuel transport to COGEMA La Hague reprocessing plant, Int. J. Radioact. Mater. Transp. 5 2–4 (1994) 273–278.
- [VI.38] EWING, R.I., “Burnup verification measurements at US nuclear utilities using the fork system”, Nuclear Criticality Safety, ICNC '95 (Proc. 5th Int. Conf. Albuquerque, 1995), Univ. of New Mexico, Albuquerque, NM (1995) 11.64–70.

- [VI.39] EWING, R.I., "Application of a burnup verification meter to actinide-only burnup credit for spent PWR fuel", Packaging and Transportation of Radioactive Materials, PATRAM 95 (Proc. Int. Symp. Las Vegas, 1995), United States Department of Energy, Washington, DC (1995).

Appendix VII

GUIDANCE FOR CALCULATION OF ACTIVITY INTAKE FOR TRANSPORT OF SCO-III

VII.1. In an accident involving an SCO-III the maximum activity intake of radionuclides for a person in the vicinity of the accident should be approximately the same as that from Type A packages (see para. 522.3), i.e. a value of $10^{-6}A_2$ or a corresponding inhalation dose of 50 mSv.

ACTIVITY INTAKE OF RADIONUCLIDES

VII.2. The activity intake of radionuclides for a person in the vicinity of an SCO-III shipment accident, Q , is given by:

$$Q = Q_{\text{INT_FIX}} + Q_{\text{INT_NF}} + Q_{\text{EXT_FIX}} \quad (\text{VII.1})$$

where

- $Q_{\text{INT_FIX}}$ is the activity intake of radionuclides due to the fixed contamination on the internal surface of the object;
- $Q_{\text{INT_NF}}$ is the activity intake of radionuclides due to the non-fixed contamination on the internal surface of the object;
- $Q_{\text{EXT_FIX}}$ is the activity intake of radionuclides due to the fixed contamination on the external surface of the object.

Note that the non-fixed contamination on the external surface for an SCO-III is not to exceed the limits specified in para. 508 of the regulations and the potential activity intake from non-fixed contamination on the external surface is therefore considered inconsequential as compared to activity intakes $Q_{\text{INT_FIX}}$, $Q_{\text{INT_NF}}$ and $Q_{\text{EXT_FIX}}$ above.

VII.3. $Q_{\text{INT_FIX}}$, the activity intake of radionuclides due to the fixed contamination on the internal surface of the object, can be calculated as follows:

$$Q_{\text{INT_FIX}} = Q_{\text{INV, INT_FIX}} \times F_{\text{SCR, INT_FIX}} \times F_{\text{REL, INT_FIX}} \times F_{\text{AER, INT_FIX}} \times F_{\text{NTK}} \quad (\text{VII.2})$$

where

$Q_{\text{INV, INT_FIX}}$ is the inventory of fixed contamination on the internal surface of the object, which for objects with homogeneous surface contamination can be determined from;

$$Q_{\text{INV, INT_FIX}} = C_{\text{INT_FIX}} \times A_{\text{INT}} \quad (\text{VII.3})$$

where

$C_{\text{INT_FIX}}$ is the level of fixed surface contamination on the internal surface per unit area;
 A_{INT} is the internal surface area of the object.

- $F_{\text{SCR, INT_FIX}}$ is the fraction of fixed contamination scraped from the internal surface in an accident;
- $F_{\text{REL, INT_FIX}}$ is the fraction of fixed contamination scraped from the internal surface that is freed and released from the object in an accident;
- $F_{\text{AER, INT_FIX}}$ is the fraction of the released activity from the fixed contamination scraped from the internal surface that is in the form of a respirable aerosol;

F_{NTK} is the fraction of the respirable released activity that is taken in by a person in the vicinity of the accident.

VII.4. $Q_{\text{INT_NF}}$, the activity intake of radionuclides due to the non-fixed contamination on the internal surface of the object, can be calculated in a similar way, except that 100% of the non-fixed contamination present on the object should be assumed to be available for release without any scraping of the surfaces required, as follows:

$$Q_{\text{INT_NF}} = Q_{\text{INV, INT_NF}} \times F_{\text{REL, INT_NF}} \times F_{\text{AER, INT_NF}} \times F_{\text{NTK}} \quad (\text{VII.4})$$

where

$Q_{\text{INV, INT_NF}}$ is the inventory of non-fixed contamination on the internal surface of the object, which for objects with homogeneous surface contamination can be determined from;

$$Q_{\text{INV, INT_NF}} = C_{\text{INT_NF}} \times A_{\text{INT}} \quad (\text{VII.5})$$

where

$C_{\text{INT_NF}}$ is the level of non-fixed surface contamination on the internal surface per unit area;

A_{INT} is the internal surface area of the object.

$F_{\text{REL, INT_NF}}$ is the fraction of the non-fixed contamination on the internal surface of the object that is freed and released from the object in an accident ($F_{\text{REL, INT_NF}}$ should be taken as unity (100%) unless the use of a lower release fraction can be justified);

$F_{\text{AER, INT_NF}}$ is the fraction of the released activity from the non-fixed contamination on the internal surface of the object that is in the form of a respirable aerosol;

F_{NTK} is the fraction of respirable released activity that is taken in by a person in the vicinity of the accident.

VII.5. $Q_{\text{EXT_FIX}}$, the activity intake of radionuclides due to the fixed contamination on the external surface of the object, can be calculated in a similar way as that for the internal surface by substituting the subscript INT by the subscript EXT in equation (VII.2), as follows:

$$Q_{\text{EXT_FIX}} = Q_{\text{INV, EXT_FIX}} \times F_{\text{SCR, EXT_FIX}} \times F_{\text{REL, EXT_FIX}} \times F_{\text{AER, EXT_FIX}} \times F_{\text{NTK}} \quad (\text{VII.6})$$

where

$Q_{\text{INV, EXT_FIX}}$ is the inventory of fixed contamination on the external surface of the object, which for objects with homogeneous surface contamination can be determined from;

$$Q_{\text{INV, EXT_FIX}} = C_{\text{EXT_FIX}} \times A_{\text{EXT}} \quad (\text{VII.7})$$

where

$C_{\text{EXT_FIX}}$ is the level of fixed surface contamination on the external surface per unit area;
 A_{EXT} is the external surface area of the object.

$F_{\text{SCR, EXT_FIX}}$ is the fraction of fixed contamination scraped from the external surface in an accident;

$F_{\text{REL, EXT_FIX}}$ is the fraction of fixed contamination scraped from the external surface that is freed and released from the object in an accident;

$F_{\text{AER, EXT_FIX}}$ is the fraction of the released activity from the fixed contamination scraped from the external surface that is in the form of a respirable aerosol;
 F_{NTK} is the fraction of respirable released activity that is taken in by a person in the vicinity of the accident.

EXAMPLE CALCULATIONS

Levels of contamination

VII.6. Since the internal surface of an SCO-III is considered as an inaccessible surface, the contamination limit is 8×10^5 Bq/cm² for the fixed contamination plus the non-fixed contamination on the internal surface. In this example, a value close to this limit is chosen for the level of the fixed contamination on the internal surface.

$$C_{\text{INT_FIX}} = 7 \times 10^5 \text{ Bq/cm}^2 \quad (\text{VII.8})$$

VII.7. For this example, a value of 400 Bq/cm² is used for the level of the non-fixed contamination on the internal surface.

$$C_{\text{INT_NF}} = 400 \text{ Bq/cm}^2 \quad (\text{VII.9})$$

VII.8. There is no limit for the fixed contamination on the external surface of SCO-III in the Transport Regulations (see para. 413.13). For this example, a value of 4×10^4 Bq/cm² is used.

$$C_{\text{EXT_FIX}} = 4 \times 10^4 \text{ Bq/cm}^2 \quad (\text{VII.10})$$

Surface areas

VII.9. For this example, values of 10 m² (10⁵ cm²) are used for both the internal surface and the external surface areas.

$$A_{\text{INT}} = A_{\text{EXT}} = 10 \text{ m}^2 = 10^5 \text{ cm}^2 \quad (\text{VII.11})$$

Fraction of surface which is scraped in an accident

VII.10. As in the SCO-I model (see para. 413.4), for this example it is considered that 20% of the internal and external surfaces are scraped during an accident.

$$F_{\text{SCR, INT_FIX}} = F_{\text{SCR, EXT_FIX}} = 0.2 \quad (\text{VII.12})$$

Fraction of the contamination from the scraped surface which is released

VII.11. For this example, it is considered that 1% of the fixed contamination from the scraped internal surface, 100% of the non-fixed contamination on the internal surface, and 20% of the fixed contamination from the scraped external surface are released from the object in an accident.

$$F_{\text{REL, INT_FIX}} = 0.01 \quad (\text{VII.13})$$

$$F_{\text{REL, INT_NF}} = 1 \quad (\text{VII.14})$$

$$F_{\text{REL, EXT_FIX}} = 0.2 \quad (\text{VII.15})$$

Fraction of the released activity that is in the form of a respirable aerosol and fraction of respirable activity that a person in the vicinity of an accident intakes

VII.12. To be consistent with the basic assumption of the Q system developed for Type A packages (see Appendix I), for this example it is considered that 100% of the released activity is in the form of a respirable aerosol and that a person in the vicinity of the accident intakes 0.01% of the respirable released activity.

$$F_{\text{AER, INT_FIX}} = F_{\text{AER, INT_NF}} = F_{\text{AER, EXT_FIX}} = 1 \quad (\text{VII.16})$$

$$F_{\text{NTK}} = 10^{-4} \quad (\text{VII.17})$$

Activity intake of radionuclides due to the fixed contamination on the internal surface

VII.13. The inventory of fixed contamination on the internal surface of the object is first calculated using equation (VII.3) as:

$$Q_{\text{INV, INT_FIX}} = C_{\text{INT_FIX}} \times A_{\text{INT}} = 7 \times 10^5 \text{ Bq/cm}^2 \times 10^5 \text{ cm}^2 = 7 \times 10^{10} \text{ Bq} \quad (\text{VII.18})$$

VII.14. The activity intake of radionuclides due to the fixed contamination on the internal surface is then calculated using equation (VII.2) as:

$$\begin{aligned} Q_{\text{INT_FIX}} &= Q_{\text{INV, INT_FIX}} \times F_{\text{SCR, INT_FIX}} \times F_{\text{REL, INT_FIX}} \times F_{\text{AER, INT_FIX}} \times F_{\text{NTK}} \\ &= 7 \times 10^{10} \text{ Bq} \times 0.2 \times 0.01 \times 1 \times 10^{-4} = 14 \times 10^3 \text{ Bq} = 14 \text{ kBq} \end{aligned} \quad (\text{VII.19})$$

Activity intake of radionuclides due to the non-fixed contamination on the internal surface

VII.15. The inventory of non-fixed contamination on the internal surface of the object is first calculated using equation (VII.5) as:

$$Q_{\text{INV, INT_NF}} = C_{\text{INT_NF}} \times A_{\text{INT}} = 400 \text{ Bq/cm}^2 \times 10^5 \text{ cm}^2 = 4 \times 10^7 \text{ Bq} \quad (\text{VII.20})$$

VII.16. The activity intake of radionuclides due to the non-fixed contamination on the internal surface is then calculated using equation (VII.4) as:

$$\begin{aligned} Q_{\text{INT_NF}} &= Q_{\text{INV, INT_NF}} \times F_{\text{REL, INT_NF}} \times F_{\text{AER, INT_NF}} \times F_{\text{NTK}} \\ &= 4 \times 10^7 \text{ Bq} \times 1 \times 1 \times 10^{-4} = 4 \times 10^3 \text{ Bq} = 4 \text{ kBq} \end{aligned} \quad (\text{VII.21})$$

Activity intake of radionuclides due to the fixed contamination on the external surface

VII.17. The inventory of fixed contamination on the external surface of the object is first calculated using equation (VII.7) as:

$$\begin{aligned} Q_{\text{INV, EXT_FIX}} &= C_{\text{EXT_FIX}} \times A_{\text{EXT}} \\ &= 4 \times 10^4 \text{ Bq/cm}^2 \times 10^5 \text{ cm}^2 = 4 \times 10^9 \text{ Bq} \end{aligned} \quad (\text{VII.22})$$

VII.18. The Activity intake of radionuclides due to the fixed contamination on the external surface is then calculated using equation (VII.6) as:

$$\begin{aligned} Q_{\text{EXT_FIX}} &= Q_{\text{INV, EXT_FIX}} \times F_{\text{SCR, EXT_FIX}} \times F_{\text{REL, EXT_FIX}} \times F_{\text{AER, EXT_FIX}} \times F_{\text{NTK}} \\ Q_{\text{EXT_FIX}} &= 4 \times 10^9 \text{ Bq} \times 0.2 \times 0.2 \times 1 \times 10^{-4} = 16 \times 10^3 \text{ Bq} = 16 \text{ kBq} \end{aligned} \quad (\text{VII.23})$$

Total activity intake of radionuclides from the object

VII.19. The total activity intake of radionuclides from the object is finally calculated using equation (VII.1) as:

$$\begin{aligned} Q &= Q_{\text{INT_FIX}} + Q_{\text{INT_NF}} + Q_{\text{EXT_FIX}} \\ &= 14 \text{ kBq} + 4 \text{ kBq} + 16 \text{ kBq} = 34 \text{ kBq} \end{aligned} \quad (\text{VII.24})$$

Conclusion of the example

VII.20. Assuming $A_2 = 0.04 \text{ TBq}$ ($4 \times 10^7 \text{ kBq}$), then the activity intake in terms of A_2 would be:

$$Q = \frac{34 \text{ kBq}}{4 \times 10^7 \text{ kBq}} A_2 = 0.85 \times 10^{-6} A_2 \quad (\text{VII.25})$$

An SCO-III, with the above assumptions, provides a level of safety equivalent to a Type A package related to the intake to a person in the vicinity of the accident as noted in para. VII.1.

VII.21. In an approval of an SCO-III shipment, every parameter in paragraphs VII.2 through VII.5 should be examined and justified. Parameters A_{INT} and A_{EXT} can be calculated from the design drawings of the components. Distributions and radionuclide compositions of parameters $C_{\text{INT_FIX}}$, $C_{\text{INT_NF}}$, and $C_{\text{EXT_FIX}}$, leading to $Q_{\text{INV, INT_FIX}}$, $Q_{\text{INV, INT_NF}}$ and $Q_{\text{INV, EXT_FIX}}$ throughout the component can be measured, or properly modelled, for a series of components, together with a verification measurement for representative points on each component. Parameters $F_{\text{SCR_INT}}$, $F_{\text{SCR_EXT}}$, F_{AER} and F_{NTK} are sensitive and should be demonstrated as being appropriate through the literature (for example Refs [VII. 1, VII. 2]), tests or reasoned argument. Parameter F_{NTK} may have a value of 10^{-4} – 10^{-3} , as described in para. I.37 in relation to the Q System.

VII.22. Care should be taken with regard to the radionuclide composition of the inventory. For example, in the case of unknown β and γ emitting radionuclides, an inventory limit of $10A_2$ corresponds to 0.2 TBq , which is equivalent to $4 \times 10^3 \text{ Bq/cm}^2$ if a surface area of 5000 m^2 (a typical internal surface area for a steam generator) is assumed. This is two orders of magnitude lower than the contamination level limit on the inaccessible surface of an SCO-III, that is $8 \times 10^5 \text{ Bq/cm}^2$. In contrast, when Co-60 is the only radionuclide present, the allowable level of inaccessible surface contamination is 4 TBq and $8 \times 10^4 \text{ Bq/cm}^2$.

REFERENCES TO APPENDIX VII

- [VII.1] UNITED STATES DEPARTMENT OF ENERGY, Airborne Release Fractions/Rates and Respirable Fraction for Nonreactor Nuclear Facilities, DOE-HDBK-3010-94, USDOE, Washington, DC (1994).
- [VII.2] GRAY, I., "Development of an improved radiological basis and revised requirements for the transport of LSA/SCO materials", Packaging and Transportation of Radioactive Materials, PATRAM 2004 (Proc. Int. Symp. Berlin 2004), Ramtrans Publishing, Ashford, UK (2004).

Appendix VIII

TRANSPORT UNDER SPECIFIC SITUATIONS

INTRODUCTION

VIII.1. This guidance is provided to anticipate specific situations, where, even if the regulatory framework is not clearly defined, safe transport may be ensured. For example, there might be no regulatory body in a country for the safe transport of radioactive material, or regulations for the safe transport of radioactive material might not have been implemented. Even where the regulatory infrastructure is in existence, some guidance might be necessary for certain special situations such as:

- (a) Transport of orphan sources that are discovered;
- (b) Subsequent transport of a package severely damaged in an accident.
- (c) Transport under emergency situations.

TRANSPORT OF ORPHAN SOURCES

VIII.2. The discovery of orphan sources will normally necessitate their transport to a safer location, for example back to the original supplier of the source or to an authorized disposal site. The consignor is required to treat the orphan source in the same manner as any other radioactive material to be transported in accordance with the Transport Regulations.

Radioactive material

VIII.3. In preparation for transport, the orphan source should be characterized (e.g. identification of the radionuclide(s), evaluation of the activity, checking for leakage and/or contamination). If the source is to be transported as special form radioactive material, the re-encapsulation of the source may be necessary when a special form certificate is not available or not applicable, i.e. when a source is beyond its recommended working life or insufficient data on the source's origin are available. Then, the re-encapsulated source has to meet the requirements for special form radioactive material. If re-encapsulation is not possible, then an appropriate package should be provided.

Package

VIII.4. The characterization of the radioactive material determines the required type of package, which in turn defines the choice of package design.

VIII.5. The dose rates and contamination levels should be measured by a qualified expert to ensure that the relevant limits are not exceeded. (See paras VIII.10–VIII.12 for guidance in the event of the absence of a regulatory body or regulations.)

Special arrangement shipment

VIII.6. In many situations involving the transport of orphan sources, shipment under special arrangement may be necessary. Prior to shipment of the package, the necessary multilateral approvals should be obtained by the consignor.

TRANSPORT OF A SEVERELY DAMAGED PACKAGE

VIII.7. A package containing radioactive material might be severely damaged in an accident. In the event of this, the package has to be removed from the public domain to a safe place. The damaged package might not meet the applicable regulations and might have to be transported in its damaged condition.

VIII.8. Recovery operations should be made, and appropriate measures might be required to ensure continued containment and shielding integrity during transport. The package might have to be transported under special arrangement (with subsequent marking and labelling), with multilateral approval and be accompanied by the applicable transport documents.

TRANSPORT UNDER EMERGENCY SITUATIONS

VIII.9. It should be noted that national and international regulations might exempt some transport operations from the application of the requirements of the Transport Regulations. For instance, [VIII.1] includes exemptions for:

- (a) The carriage undertaken by, or under the supervision of, the competent authorities for the emergency response, insofar as such carriage is necessary in relation to the emergency response, in particular carriage undertaken:
 - By breakdown vehicles carrying vehicles which have been involved in accidents or have broken down and contain dangerous goods; or
 - To contain and recover the dangerous goods involved in an incident or accident and to move them to the nearest appropriate safe place.
- (b) Emergency transport intended to save human lives or to protect the environment, provided that all measures are taken to ensure that such transport is carried out in complete safety.

TRANSPORT WITHIN/TO/FROM/THROUGH A COUNTRY WITHOUT A REGULATORY BODY OR REGULATIONS FOR THE SAFE TRANSPORT OF RADIOACTIVE MATERIAL

VIII.10. Some countries have not established a regulatory infrastructure for the safe transport of radioactive material. For transport of radioactive material in such situations, the consignor/consignee should contact the IAEA's Division of Radiation, Transport and Waste Safety for guidance regarding the procedure to follow.

VIII.11. If no regulations for the safe transport of radioactive material are implemented in a country, the Transport Regulations (i.e. current edition of IAEA Safety Standards Series No. SSR-6) should be applied for the transport within, from, to or through that country.

VIII.12. If no regulatory body for the safe transport of radioactive material is appointed in a country, the first certificate of approval (special arrangement), which should be approved by all countries relevant to the shipment, may be issued by the existing national radiation protection

regulator of the country. The IAEA's Division on Radiation, Transport and Waste Safety can provide guidance on the application of international regulations on transport safety.

Completion of shipment

VIII.13. In such special situations, the competent authority or the concerned safety regulator should continue tracking the shipment until its safe completion. The consignor should inform the appropriate authority about the safe completion of such shipments.

REFERENCES TO APPENDIX VIII

[VIII.1] UNITED NATIONS ECONOMIC COMMISSION FOR EUROPE, INLAND TRANSPORT COMMITTEE, European Agreement Concerning the International Carriage of Dangerous Goods by Road (ADR), 2019 Edition, UNECE, New York and Geneva (2018).

CONTRIBUTORS TO DRAFTING AND REVIEW

Acena Moreno, Maria Victoria	Consejo de Seguridad Nuclear, Spain
Alvano, Paolo	ISPRA, Italy
Ben Ouaghrem, Karim	Institut de radioprotection et de sûreté nucléaire , France
Börst, Frank-Michael	Bundesamt für Strahlenschutz, Germany
Boyle, Richard	U.S. Department of Transportation, United States of America
Buchelnikov, Alexander	State Atomic Energy Corporation, Russian Federation
Cabianca, Tiberio	Health Protection Agency, United Kingdom
Capadona, Nancy	International Atomic Energy Agency
Charette, Marc André	Cameco Corporation, Canada
Chrupek, Thierry	Autorité de Sûreté Nucléaire, France
Debruyne, Marika	Institut de radioprotection et de sûreté nucléaire, France
Desnoyers, Bruno	International Organization for Standardization
Elechosa, Christian	Autoridad Regulatoria Nuclear, Argentina
Ershov, Vladimir N.	Emergency Response Center, Russian Federation
Faille, Sylvain	Canadian Nuclear Safety Commission, Canada
	Bundesamt für Kerntechnische Entsorgungssicherheit, Germany
Fasten, Christel	
Ferran, Ghislain	Autorité de Sûreté Nucléaire, France
Fukuda, Takuji	Secretariat of Nuclear Regulation Authority, Japan
Gauthier, Florence	Institut de radioprotection et de sûreté nucléaire, France
Hellsten, Santtu	Radiation and Nuclear Safety Authority, Finland
Hirose, Makoto	Secretariat of Nuclear Regulation Authority, Japan
Ito, Daiichiro	Nuclear Fuel Transport Co., Japan
Kervella, Olivier	Economic Commission for Europe
	Federal Ministry for Transport, Innovation and Technology, Austria
Kirchnawy, Friedrich	
Koch, Frank	Nuclear Safety Inspectorate, Switzerland
Komann, Steffen-Michael	Bundesanstalt für Materialforschung und - prüfung, Germany
Konnai, Akiko	National Maritime Research Institute, Japan
Krochmaluk, Julie	Autorité de Sûreté Nucléaire, France
Lizot, Marie-Therese	Institut de Radioprotection et de Sûreté Nucléaire, France
Malesys, Pierre	World Nuclear Transport Institute
Moutarde, Marianne	Institut de radioprotection et de sûreté nucléaire, France
Muneer, Muhammad	Pakistan Nuclear Regulatory Authority, Pakistan
	NAC Atlanta Corporate Headquarters, United States of America
Patko, Anthony L.	
Presta, Anne	World Nuclear Transport Institute
Pstrak, David	U.S. Nuclear Regulatory Commission, United States of America
Rainer, Nöring	Gesellschaft für Nuklear-Service, Germany
Ramsay, Jeff	Canadian Nuclear Safety Commission, Canada
	Bundesamt für Kerntechnische Entsorgungssicherheit, Germany
Reiche, Ingo	
Rooney, Katherine	International Civil Aviation Association

Sampson, Michele	U.S. Nuclear Regulatory Commission, United States of America
Sert, Gilles	Institut de Radioprotection et de Sûreté Nucléaire, France
Vogiatzi, Stavroula	Greek Atomic Energy Commission, Greece
Tremblay, Isabelle	Canadian Nuclear Safety Commission, Canada
Trivelloni, Sandro	ISPRA, Italy
van Aarle, Jan	AXPO AG/Nuclear Energy, Switzerland
Wallin, Michael	Swedish Radiation Safety Authority, Sweden
Whittingham, Stephen	International Atomic Energy Agency
Zamora Martin, Fernando	Consejo de Seguridad Nuclear, Spain
Zika, Helmuth	Swedish Radiation Safety Authority, Sweden